



Makita[®]

2026 PRODUCT

Screwing/
Drilling 28

Stirring 56

Hammer
drilling/
Chiselling 59

Grinding/
Sanding/
Polishing 77

Cutting 104

Sawing 112

Milling/
Planing 127

Fastening/
Fixing 133

Cleaning 138

Lawn care/
Grass care 152

Tree care/
Hedge care 166

Transportation 176

Measuring/
Leveling 177

Lights 180

Comfort/
Lifestyle 185

Speciality tools 192

Accessory 195

D		D		D		D		D	
DGA506	80	DKP180	130	DRT50	127	DTWA140	55	DVC350	141
DGA508	81	DKP181	130	DRT52	127	DTWA190	55	DVC560	144
DGA511	80	DKT360	191	DRV150	133	DTWA260	55	DVC660	142
DGA512	79	DLM330	155	DRV250	133	DUA200	170	DVC665	142
DGA513	79	DLM382	155	DS4011	37	DUA250	170	DVC750L	141
DGA514	79	DLM432	155	DS4012	37	DUA251	170	DVC860L	139
DGA517	80	DLM462	155	DS5000	37	DUA300	170	DVC861L	139
DGA518	80	DLM465	155	DSC102	107	DUA301	170	DVC865L	139
DGA519	80	DLM466	155	DSC121	107	DUB184	149	DVC866L	139
DGA520	81	DLM480	154	DSC163	107	DUB185	149	DVC867L	139
DGA521	80	DLM481	154	DSC191	107	DUB186	149	DVP180	192
DGA700	79	DLM530	154	DSC251	107	DUB187	148	DVP181	192
DGA701	79	DLM532	154	DSD180	126	DUB361	148	DVR350	56
DGA900	79	DLM533	154	DSL801	102	DUB362	148	DVR450	56
DGA901	79	DLM534	154	DSP600	122	DUB363	148	DVR850	56
DGD800	96	DLM536	154	DSP601	122	DUC101	169	DWR180	45
DGD801	96	DLM537	154	DSS501	118	DUC122	168	DWT310	46
DGP180	192	DLM538	154	DSS610	118	DUC150	169	DX08	61
DHG180	194	DLM539	154	DSS611	118	DUC256	167	DX09	61
DHG181	194	DLS110	112	DST112	137	DUC256C	167	DX10	59
DHK180	73	DLS111	112	DST221	137	DUC258	168	DX11	59
DHP451	30	DLS112	112	DST630	136	DUC303	167	DX15	59
DHP453	31	DLS211	112	DTC100	110	DUC305	168	DX16	60
DHP458	30	DLS212	112	DTC101	110	DUC306	167	DX17	60
DHP482	31	DLS600	113	DTC102	110	DUC307	168	DX18	60
DHP484	29	DLS713	113	DTC103	110	DUC353	167	E	
DHP485	30	DLS714	113	DTC104	110	DUC355	168	EE400MP	162
DHP486	29	DLW140	106	DTC301	110	DUC356	167	EJ400MP	162
DHP487	30	DMC300	107	DTC302	110	DUC357	168	ELM3320	156
DHP489	29	DML185	183	DTC303	110	DUC400	167	ELM3720	156
DHP490	30	DML800	184	DTD043	54	DUC405	168	ELM4120	156
DHR165	62	DML801	184	DTD063	54	DUC406	167	ELM4121	155
DHR171	62	DML802	183	DTD064	54	DUC407	168	ELM4620	155
DHR182	61	DML803	184	DTD103	54	DUH501	171	ELM4621	155
DHR183	61	DML805	182	DTD104	54	DUH502	171	EM402MP	162
DHR202	61	DML806	183	DTD152	35	DUH506	171	EM403MP	162
DHR241	61	DML807	183	DTD153	35	DUH507	172	EM404MP	162
DHR242	61	DML808	183	DTD156	35	DUH601	171	EM405MP	162
DHR243	61	DML809	182	DTD157	35	DUH602	171	EM406MP	162
DHR263	61	DML811	182	DTD173	35	DUH604S	172	EM407MP	162
DHR264	61	DML812	183	DTD201	35	DUH606	171	EM408MP	162
DHR280	61	DML814	182	DTDA040	54	DUH607	172	EM409MP	162
DHR281	60	DML816	184	DTDA070	54	DUH751	171	EN401MP	162
DHR282	60	DML817	184	DTDA100	54	DUH752	171	EN402MP	162
DHR283	60	DML818	182	DTDA140	54	DUH754S	172	EN410MP	162
DHR400	60	DML819	182	DTL061	37	DUM111	165	EN420MP	162
DHS630	117	DMP180	190	DTL063	45	DUM604	165	EN421MP	162
DHS660	117	DMP181	190	DTL300	45	DUN461W	174	EN422MP	162
DHS661	117	DMR055	186	DTL301	45	DUN500W	174	EN424MP	162
DHS680	117	DMR056	186	DTL302	45	DUN501W	174	EN425MP	162
DHS710	117	DMR057	186	DTM50	111	DUN600L	174	EY402MP	162
DHS780	117	DMR112	186	DTM52	111	DUN601L	174	EY403MP	162
DHS781	117	DMR115	186	DTM53	111	DUP180	175	F	
DHS782	117	DMR116	186	DTP141	37	DUP181	175	FN001G	135
DHS783	117	DMR203	186	DTR180	133	DUP361	175	FS2200	49
DHS900	116	DMR300	185	DTR181	133	DUP362	175	FS2300	48
DHS901	117	DMR301	185	DTS141	37	DUR189	160	FS2500	47
DHW080	150	DP2010	38	DTW073	55	DUR190L	159	FS2700	47
DHW180	151	DP2011	38	DTW074	55	DUR190U	159	FS2701	47
DJN161	109	DP4000	38	DTW1001	42	DUR192L	160	FS4000	48
DJR183	125	DP4002	38	DTW1002	42	DUR193	160	FS4200	48
DJR185	125	DP4003	38	DTW1004	43	DUR368A	159	FS4300	48
DJR186	125	DP4010	37	DTW1005	42	DUR368L	159	FS6200	49
DJR187	125	DP4011	37	DTW103	55	DUR369A	159	FS6300	49
DJR188	125	DP4020	38	DTW104	55	DUR369L	159	FS6300R	49
DJR189	125	DP4021	38	DTW180	44	DUR369N	159	G	
DJR360	125	DPB180	108	DTW181	43	DUS054	175	GA003G	77
DJS101	109	DPB182	108	DTW190	43	DUS108	175	GA004G	77
DJS130	109	DPB183	108	DTW251	43	DUS158	175	GA005G	77
DJS131	108	DPB184	108	DTW253	43	DUT130	57	GA006G	77
DJS161	109	DPJ180	130	DTW300	43	DUT131	57	GA007G	77
DJS200	108	DPO500	97	DTW301	43	DUV320	156	GA008G	77
DJS800	109	DPO600	97	DTW302	43	DUX18	164	GA011G	77
DJV180	123	DPP200	108	DTW450	43	DUX60	164	GA012G	77
DJV181	123	DPT353	136	DTW700	43	DVC155L	139	GA013G	77
DJV182	123	DPV300	95	DTW701	43	DVC156L	139	GA014G	77
DJV184	123	DRC200	144	DTW800	43	DVC157L	138	GA015G	77
DJV185	123	DRC300	144	DTWA070	55	DVC261	142	GA016G	77
DJV186	123	DRS780	121	DTWA100	55	DVC265	142	GA021G	78

M		R		U		U	
ML011G	184	RT0702C	127	UB004C	148	UR016G	159
ML012G	182	S		UB100D	149	UR017G	159
ML013G	182	SA5040C	94	UB101D	149	UR100D	160
ML102	184	SA7000	94	UB1102	149	UR101C	158
ML104	183	SA7000C	94	UB1103	149	UR140D	160
ML107	184	SC001G	107	UB402MP	162	UR180D	160
MLT100N	116	SC103D	107	UB403MP	162	UR201C	158
MP001G	190	SD100D	126	UC002G	166	UR202C	158
MP100D	190	SG1251	106	UC003G	166	UR2300	161
MR001G	185	SJ401	126	UC004G	166	UR3000	161
MR002G	185	SK105D	178	UC005G	166	UR3500	161
MR003G	185	SK105GD	178	UC006G	166	UR3501	161
MR004G	185	SK106D	178	UC007G	166	UR3502	161
MR006G	185	SK106GD	177	UC010G	167	US053D	175
MR007G	185	SK10GD	177	UC011G	167	UT001G	57
MR009G	186	SK209GD	177	UC012G	167	UT002G	57
MR010G	186	SK20GD	177	UC013G	167	UT1200	58
MR014G	186	SK312GD	177	UC014G	167	UT1305	57
MR051	186	SK40GD	177	UC015G	167	UT1400	58
MR052	186	SK700D	177	UC016G	167	UT1401	57
MW001G	191	SK700GD	177	UC017G	167	UT1600	57
N		SKR001	178	UC020G	167	UT2204	57
N3701	128	SKR200Z	178	UC021G	167	UV001G	156
N5900B	119	SN001G	192	UC022G	167	UV3200	156
N9500N	86	SN400MP	162	UC023G	167	UV3600	156
P		SP001G	122	UC024G	166	UX01G	164
PB002G	108	SP6000	122	UC025G	166	V	
PC5000C	131	ST113D	137	UC026G	166	VC001GL	138
PC5001C	131	SW400MP	162	UC029G	169	VC002GL	138
PC5010C	131	T		UC030G	166	VC003GL	138
PDC1200	24	TD001G	35	UC031G	166	VC004GL	138
PDC1500	24	TD002G	35	UC100D	169	VC005GL	138
PF0300	193	TD003G	35	UC3041A	169	VC006GM	138
PF0403	193	TD004G	35	UC3050A	169	VC007GL	138
PF0410	193	TD0100	36	UC3051A	169	VC008G	142
PF0610	193	TD0101	36	UC3541A	169	VC009G	142
PF0800	193	TD0101F	36	UC3550A	169	VC010G	144
PF1010	193	TD022D	36	UC3551A	169	VC011G	142
PF1100	193	TD090D	36	UC4041A	169	VC012G	142
PF1110	193	TD091D	55	UC4050A	169	VC013GL	141
PF400MP	162	TD110D	36	UC4051A	169	VC014GL	141
PJ7000	130	TD111D	36	UC4550A	169	VC1310L	140
PK5011C	94	TD112D	54	UC4551A	169	VC2000L	141
PM001G	175	TD127D	36	UD2500	156	VC2012L	141
PO5000C	98	TL064D	37	UE001G	161	VC2201M	140
PO6000C	98	TL065D	45	UH004G	171	VC2211M	140
PP001G	108	TM001G	111	UH005G	171	VC2510L	140
PS001G	151	TM3000C	111	UH006G	171	VC2512L	140
PT001G	136	TM3010C	111	UH007G	171	VC3011L	140
PT354D	136	TM30D	111	UH008G	171	VC3012L	140
PV001G	94	TR001G	133	UH009G	171	VC3012M	140
PV301D	95	TW001G	42	UH013G	172	VC3210L	139
PV7000C	95	TW002G	42	UH014G	172	VC3211H	139
PV7001C	95	TW003G	42	UH020G	171	VC3211M	139
PW5000C	95	TW004G	42	UH021G	171	VC4210L	140
PW5001C	95	TW005G	42	UH200D	172	VC4210M	140
R		TW007G	42	UH201D	172	VR001C	56
RD1101	129	TW008G	42	UH4261	173	VR001G	56
RF1101	129	TW010G	42	UH4570	173	VR002C	56
RM350D	152	TW011G	42	UH4861	173	VR003C	57
RP001G	128	TW0200	45	UH5261	173	VR003G	56
RP0900	129	TW0350	45	UH5570	173	VR004C	57
RP0910	129	TW060D	44	UH5580	173	VR004G	56
RP1101	129	TW1000	44	UH6570	173	VS001G	144
RP1111C	129	TW100D	44	UH6580	173	W	
RP1800	129	TW140D	44	UH7580	173	WA400MP	162
RP1800F	129	TW141D	44	UM164D	165	WR100D	45
RP1802	128	TW160D	44	UM600D	165	WT001G	46
RP1802F	128	TW161D	44	UN001G	174		
RP1803	129	TW202D	44	UN460WD	174		
RP1803F	128	U		UP100D	175		
RP2300FC	128	UA001G	170	UR002G	158		
RP2301FC	128	UA002G	170	UR003G	159		
RP2302FC	128	UA003G	170	UR006G	158		
RP2303FC	128	UA004G	170	UR007G	158		
RS001G	121	UB001G	148	UR008G	158		
RS002G	121	UB002G	148	UR012G	158		
RT001G	127	UB003C	148	UR013G	158		
RT0700C	127	UB003G	148	UR014G	158		



2026 New Products



New Products

Cordless Driver Drill

40Vmax

DF003G p.29



Cordless Angle Impact Wrench

18V

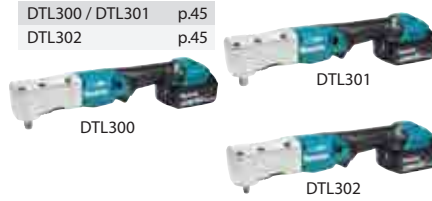
 DTL300 / DTL301 p.45
 DTL302 p.45

Cordless Cable Cutter

18V

DTC104 p.110



Cordless Hammer Driver Drill

40Vmax

HP003G p.29



Cordless Combination Hammer

40Vmax

HR011G / HR012G p.60



Cordless Crimper

18V

 DTC301 / DTC302 p.110
 DTC303 p.110

Cordless Driver Drill

18V

DDF490 p.30



Dust Collection System

Attachment

DX17 / DX18 p.60



Cordless Multi Tool

18V

DTM53 p.111



Cordless Hammer Driver Drill

18V

DHP490 p.30



Cordless Flat-head Angle Grinder

40Vmax

 GA055G p.77
 GA056G p.77

Cordless Jig Saw

18V

DJV186 p.123



Cordless Impact Driver

18V

DTD201 p.35



Angle Grinder

40Vmax

 GA4100 / GA4600 p.85
 GA5100 p.85

Cordless Recipro Saw

40Vmax

JR003G p.125



Cordless Impact Wrench

40Vmax

TW011G p.42



Cordless Die Grinder

40Vmax

GD002G / GD001G p.96



Cordless Rebar Tying Tool

40Vmax

TR001G p.133



Cordless Impact Wrench

18V

DTW1005 p.42



Cordless Steel Rod Cutter

40Vmax

SC001G p.107



Cordless Framing Nailer

40Vmax

BN001G / BN002G p.133

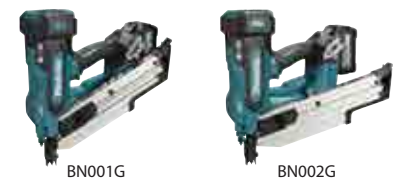

Cordless Narrow Crown Stapler

18V

DST630 p.136



Cordless Lawn Mower

18V x2

DLM466 p.155



Cordless Grease Gun

40Vmax

GP001G p.192



Cordless Finish Nailer

18V

DBN620 p.135
DBN610 / DBN601 p.135



Cordless Chain Saw

40Vmax

UC031G p.166
UC030G p.166



Cordless Heat Gun

40Vmax

HG001G p.194



Cordless Brad Nailer

18V

DBN501 p.135



Cordless Chain Saw

18V

DUC258 p.168



Car Cigarette Lighter Adapter

Accessory

ADP14 p.195



Cordless Vacuum Cleaner

40Vmax

VC013GL / VC014GL p.141



Cordless Pruning Shears

18V

DUP181 p.175



Cordless Cleaner

40Vmax

CL004G p.145



Cordless Magnetic Light

40Vmax

ML013G p.182



Cordless Cleaner

12Vmax

CL200FD p.145



Cordless Magnetic Light

18V

DML819 p.182



Cordless Blower

40Vmax

UB003G p.148
UB002G p.148



Cordless Snow Blower

40Vmax

SN001G p.192



XGT Battery Series



Max Output

0.9 kW



Max Output

1.1 kW



Max Output

1.5 kW



2.0Ah BL4020



2.5Ah BL4025

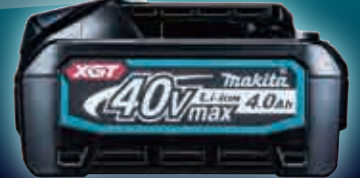

4.0Ah BL4040

XGT is a new system with its own tools, batteries, and chargers. A combination of innovative tool design and higher output batteries provide a genuine solution for high demand industrial users.

Optimum power supply system and Optimum charging system

The XGT range of tools and batteries come with a built-in program, providing digital communication between the battery and tool. Allowing not only for the battery to talk with tool but also the tool to talk to the battery. Battery technology and motor engineering that work together for optimum performance.

Tool ◀▶ Battery ◀▶ Battery Charger
Digital communication

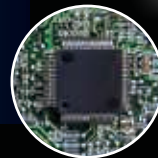

Optimum charging system

Auto maintenance system with two cooling fans for providing more optimum fast charging

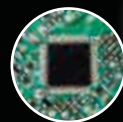

40Vmax mechanism movie

This movie was filmed in Japan. Models and specs may vary by country.



Max Output
2.1 kW

Max Output
2.8 kW

Max Output
3.8 kW

POWER

4.0Ah BL4040F | **5.0Ah** BL4050F | **8.0Ah** BL4080F | **8.0Ah** BL4080H

Built Tough

High durability specifications specially designed for 40Vmax Li-Ion batteries

4-LED fuel gauge indicator

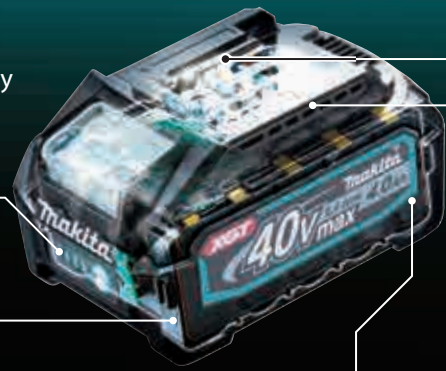

Terminal short-circuit prevention structure
The protection wall is provided between terminals against water and dust.

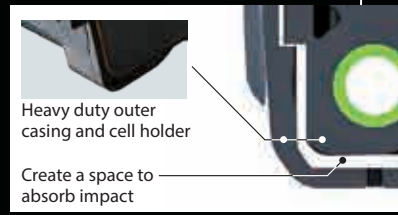

Shock absorption structure

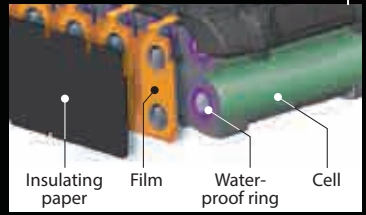

Waterproof Triple-layer Structure
prevents cell failure due to water and dust.

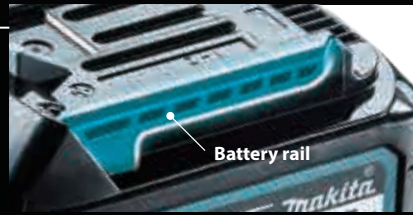

High Rigidity Battery Rails
Durable slide in battery rail that holds the battery and the tools firmly and securely to withstand high power products

High Output Battery Series



BL4040F
[Tab-less]



BL4050F



BL4080F



BL4080H
[Tab-less]



Unlocks the full power potential for certain models.



Demonstrates tenacity even under heavy load.

BL4040F Tab-less Battery

Traditional



Higher electrical resistance

Energy converts to heat

Leading to energy loss

Tab-less

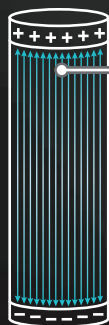

Lower electrical resistance

Energy does not easily convert to heat

Minimal energy loss

BL4050F (Traditional)



20 cells
(2P10S)

BL4040F (Tab-less)



10 cells
(1P10S)



Unlocks the full power potential for certain models.

By using the high output battery, the overload indicator setting changes thanks to the smart system, allowing for continuous heavy load work, thereby improving efficiency and unlocking the full power of certain models.

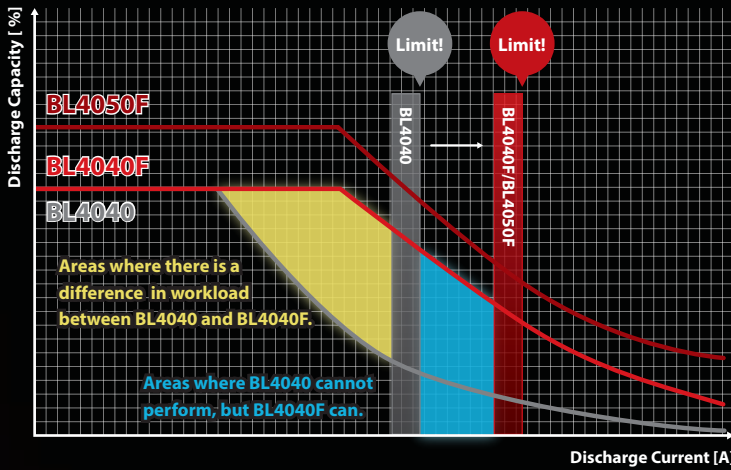

Cordless Chain Saw
UC017G (42cc Class)
 Cutting ø300mm cedar log

Standard [BL4040]	9.7 sec.
High Output Battery [BL4040F / BL4050F]	6.9 sec. UP TO 29% FASTER



Demonstrates tenacity even under heavy load.

By using the high output battery, it is less likely to slow down under heavy load, demonstrating tenacity and leading to increased efficiency. Despite having the same battery capacity, the work output per charge with the BL4040F can be higher than the BL4040 under high load conditions.

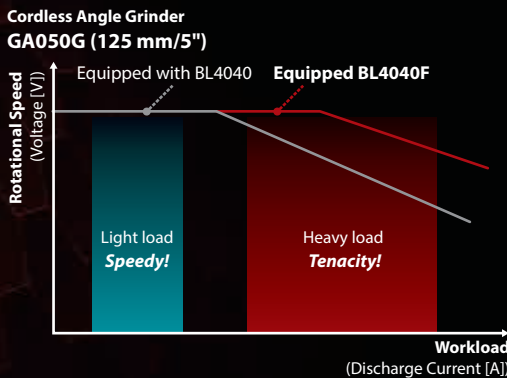

Cordless Angle Grinder
GA038G (230mm/9")
 Cutting concrete continuously at depth of 40mm

Work amount per charge

Standard [BL4040]	240 cm
High Output Battery [BL4040F / BL4050F]	410 cm UP TO 71% LONGER

Achieves increased continuous output performance under heavy load, which is equivalent to BL4050F, while maintaining the same size as BL4040.



vs BL4040

36%
 MORE POWER

32%
 COOLER

vs BL4050F

28%
 LESS WEIGHT

32%
 MORE COMPACT



40V Li-ion max

High Power

Durability

Digital Communication



Rotary Hammer



Demolition Hammer



Power Cutter



Breaker



Grass Trimmer



Vacuum Cleaner

Battery

BL4020 2.0Ah	BL4025 2.5Ah	BL4040 4.0Ah	BL4040F 4.0Ah
------------------------	------------------------	------------------------	-------------------------





240+
TOOLS

Charger

BL4050F
5.0Ah

BL4080F
8.0Ah

BL4080H
8.0Ah

DC40RA

DC40RB

DC40WA

DC40RC

ADP10



Adapter for LXT Battery



Chain Saw

Pole Saw

Grass Trimmer

Pruning Shears

Lawn Mower

Earth Auger

Vacuum Pump

High Pressure Washer

Wheelbarrow

Kettle

Portable Power Pack

Impact Wrench

Blower

Vacuum Cleaner

Multi Function Power Head

Auto Feed Screwdriver

Concrete Vibrator

Oil-Pulse Driver

Mixer

Screwdriver

4 Mode Impact Driver

18V x2

420+ TOOLS

6.0Ah 5.0Ah 4.0Ah
3.0Ah 2.0Ah 1.5Ah

Angle Drill

Angle Impact Wrench

Ratchet Wrench

Impact Driver

Angle Impact Driver

Driver Drill

Hammer Driver Drill

Rotary Hammer

Die Grinder

Multi Tool

Steel Rod Cutter

Sander Polisher

Power Scraper

Combination Hammer

Random Orbit Polisher

Angle Grinder

Metal Shear

Finishing Sander

Drywall Sander

Random Orbit Sander

Recipro Saw

Cable Cutter

Hole Puncher

Compact Cut Off

Belt Sander

Threaded Rod Cutter

Crimper

Nibbler

Cutter

Metal Cutter

Compound Miter Saw

Slide Compound Miter Saw

Portable Band Saw

Expand Your Lithium Line Up

12V_{max} LITHIUM-ION

90 TOOLS
4.0Ah 2.0Ah 1.5Ah
EXPAND YOUR LITHIUM-ION LINEUP

The collage features the following tools and accessories:

- Job Site Radio
- Job Site Speaker
- Rotary Laser
- Multi Line Laser
- Green Multi Line Laser
- Green 4-point Cross Line Laser
- Red 4-point Cross Line Laser
- Adapter for USB
- Driver Drill
- Hammer Driver Drill
- Impact Driver
- Angle Drill
- Impact Wrench
- Rotary Hammer
- Ratchet Wrench
- Angle Impact Driver
- Circular Saw
- Multi Cutter
- Threaded Rod Cutter
- Cutter
- Recipro Saw
- Drywall Saw
- Multi tool
- Pin Nailers
- Jig Saw
- Stapler
- Sander Polisher
- Garden Sprayer
- Caulking Gun
- Pruning Shears
- Pruning Saw
- Hedge Trimmer
- Inflator
- Blower
- Grass Trimmer
- Grass Shear
- Worklight
- LED Worklight
- Cordless Cleaner
- Fan Jacket
- Fan Vest
- Fan
- Heated Jacket
- Heated Vest
- Heated Base Layer Shirt
- Heated Blanket



10.8V Lithium-ion



7.2V Lithium-ion



A wide variety of Lithium-ion Garden Tools

Direct power connection

40V max x2

64V max

12V max

Build in battery

PDC1500 / PDC1200

Grass Trimmer

Lawn Mower

Blower

Backpack Blower

Power Cutter*

Grass Trimmer*

Blower

Pruning Saw

Lawn Mower

Lawn Mower

Pruning Shears

Recipro Saw

Blower

Pruning Saw

Garden Sprayer

Hedge Trimmer

Grass Shear

Pole Hedge Trimmer

Grass Trimmer

Grass Trimmer

Robotic Mower

Garden Sprayer

Grass Trimmer

Scarifier

Multi Function Power Head

* These models are not compatible with Portable Power Pack (PDC1500, PDC1200)
Only 18Vx2 rear handle type chainsaws are compatible

**These models are not compatible with Portable Power pack (PDC1500)

40V max

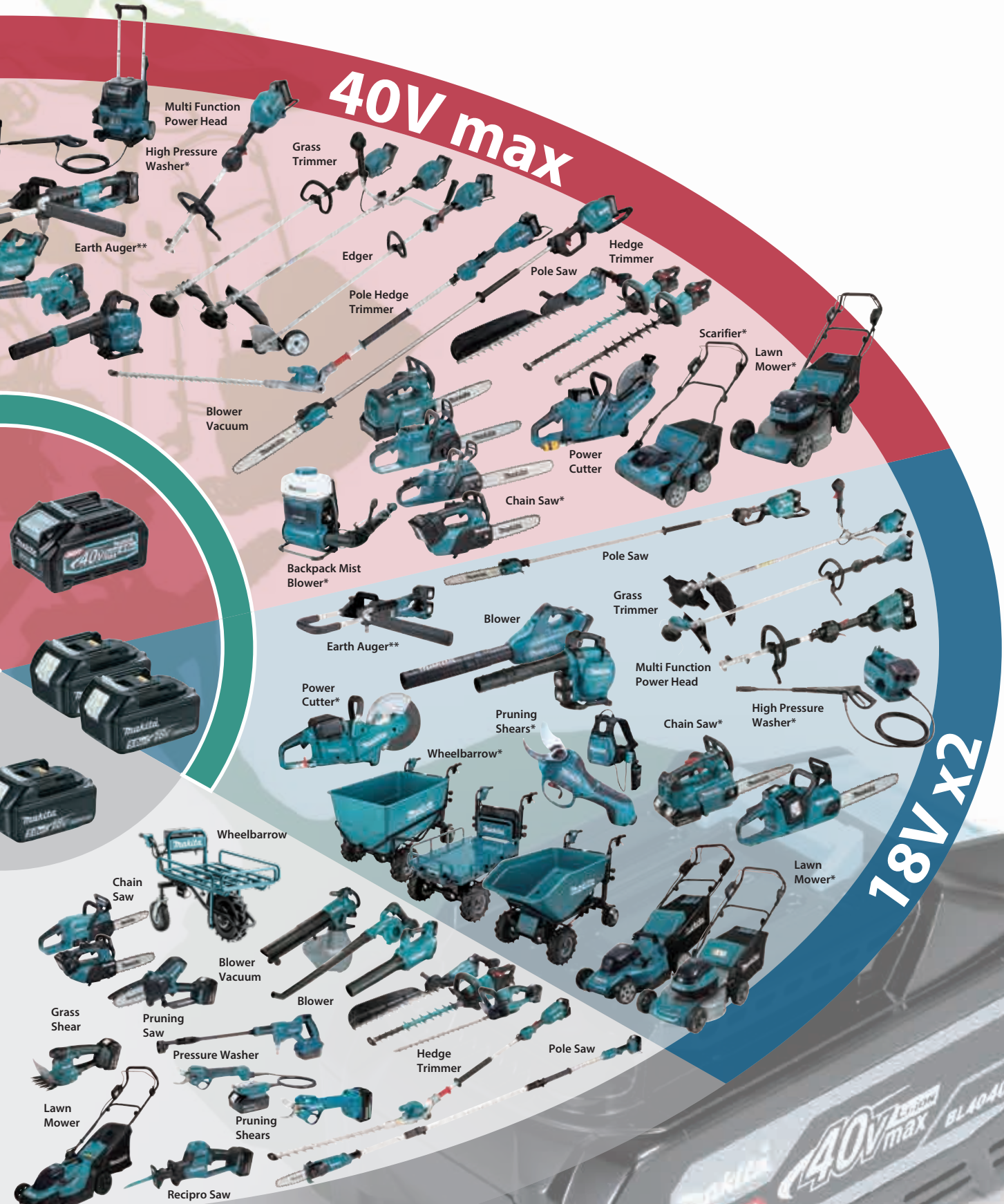

Multi Function Power Head

High Pressure Washer*

Grass Trimmer

Earth Auger**

Edger

Hedge Trimmer

Pole Hedge Trimmer

Pole Saw

Scarifier*

Lawn Mower*

Blower Vacuum

Power Cutter

Chain Saw*

Backpack Mist Blower*

Pole Saw

Grass Trimmer

Earth Auger**

Blower

Multi Function Power Head

High Pressure Washer*

Power Cutter*

Pruning Shears*

Chain Saw*

Wheelbarrow*

Lawn Mower*

Wheelbarrow

Chain Saw

Blower Vacuum

Blower

Grass Shear

Pruning Saw

Pressure Washer

Hedge Trimmer

Pole Saw

Lawn Mower

Pruning Shears

Recipro Saw

18V

18V X2



Rapid Optimum Charging System

It is necessary to cool down before start charging when the battery temperature is high. Built-in fan circulates air through the battery before start charging and during the charging process to cool the battery for faster charge time.

The optimum charging system

Forced air cooling Fast charging



General charging method

Natural heat dissipation Waiting time for charging

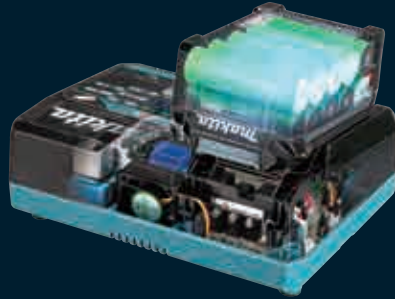

The Makita Rapid Optimum Charger communicates with the battery's built-in chip throughout the charging process to optimize battery life by actively controlling current, voltage and temperature.



The optimum charging system

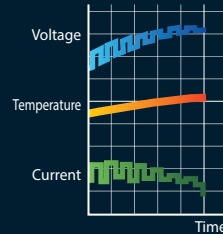

General charging method

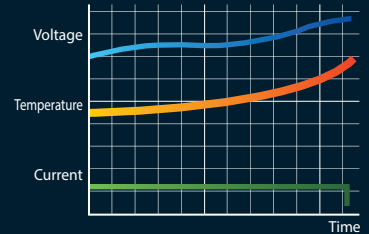

Li-ion Battery & Charging Time Reference, Compatibility Chart

Battery Model	Capacity	Fast Charging		DC40RC		DC40WA		BCC01		BCC02	
		The practical charging time	Full battery charge	The practical charging time	Full battery charge	The practical charging time	Full battery charge	4 ports	8 ports	4 ports	12 ports
BL4080H	8.0Ah	60 min.	76 min.	130 min.	170 min.	335 min.	420 min.	280 min.	560 min.	-	-
BL4080F	8.0Ah	60 min.	76 min.	130 min.	170 min.	335 min.	420 min.	280 min.	560 min.	-	-
BL4050F	5.0Ah	38 min.	50 min.	65 min.	85 min.	205 min.	260 min.	175 min.	350 min.	-	-
BL4040F BL4040	4.0Ah	31 min.	45 min.	52 min.	67 min.	165 min.	210 min.	145 min.	290 min.	145 min.	435 min.
BL4025	2.5Ah	19 min.	28 min.	27 min.	38 min.	105 min.	130 min.	90 min.	180 min.	90 min.	270 min.
BL4020	2.0Ah	15 min.	22 min.	22 min.	30 min.	85 min.	110 min.	75 min.	150 min.	75 min.	225 min.

Battery Charging Case With multiple charging ports for 40Vmax XGT Li-Ion batteries

BCC01: 8 ports

BCC02: 12 ports



Switch charging of batteries attached to multiple ports

Capable of charging all batteries on four ports simultaneously. Equipped with a feature that automatically switches batteries to charge them.

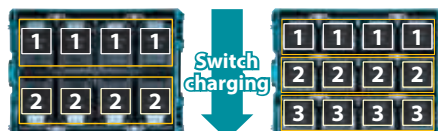

18V batteries can be charged using an adapter (BCC01 only)



Interchangeable adapter ADP10

18V LITHIUM-ION		Fast Charging DC40RA+ADP10 Compatible with LXT Li-Ion batteries		DC40RC+ADP10 Compatible with LXT Li-Ion batteries		Fast Charging DC18RC		DC18SD	DC18WC	DC18SF	DC18SJ			BCC01+ADP10		
		The practical charging time	Full battery charge	The practical charging time	Full battery charge	The practical charging time	Full battery charge			1 to 2 batteries	3 to 4 batteries	PD 60W	PD 80W	PD 100W	4 ports	8 ports
BL18120 12.0Ah		48 min.	70 min.	130 min.	175 min.	120 min.	265 min.	325 min.	265 min.	530 min.	280 min.	210 min.	220 min.	330 min.	660 min.	
BL1890 9.0Ah		35 min.	59 min.	100 min.	135 min.	85 min.	200 min.	245 min.	200 min.	400 min.	215 min.	155 min.	150 min.	250 min.	500 min.	
BL1860B 6.0Ah		27 min.	40 min.	66 min.	85 min.	55 min.	130 min.	160 min.	130 min.	260 min.	145 min.	105 min.	100 min.	160 min.	320 min.	
BL1850B 5.0Ah		26 min.	35 min.	56 min.	70 min.	45 min.	110 min.	135 min.	110 min.	220 min.	120 min.	90 min.	84 min.	135 min.	270 min.	
BL1840B 4.0Ah		-	29 min.	-	58 min.	36 min.	90 min.	110 min.	90 min.	180 min.	95 min.	70 min.	67 min.	110 min.	220 min.	
BL1830B 3.0Ah		17 min.	22 min.	32 min.	42 min.	22 min.	60 min.	80 min.	60 min.	120 min.	70 min.	50 min.	48 min.	80 min.	160 min.	
BL1820B 2.0Ah		-	24 min.	-	33 min.	24 min.	45 min.	55 min.	45 min.	90 min.	50 min.	39 min.	38 min.	55 min.	110 min.	
BL1815N 1.5Ah		-	15 min.	-	22 min.	15 min.	30 min.	40 min.	30 min.	60 min.	35 min.	28 min.	27 min.	40 min.	80 min.	

*DC18RD / DC18SH: Charges two LXT batteries simultaneously. **DC18RE: Charges LXT and CXT battery alternatively

DCB18WA

90 min.

Battery and charger compatibility

Charge the LXT batteries with the LXT battery chargers and the LXT BASIC battery with the LXT BASIC battery charger.

12Vmax LITHIUM-ION		Fast Charging DC10SB		DC10WD		40Vmax Lithium-ion 18V x2 Lithium-ion		DC4001	64Vmax LITHIUM-ION		DC64WA	
BL1050B 5.0Ah		76 min.	160 min.						BL64100 10.0Ah		300 min.	
BL1041B 4.0Ah		60 min.	130 min.						BL6440 4.0Ah		120 min.	
BL1021B 2.0Ah		30 min.	70 min.									
BL1016 1.5Ah		22 min.	50 min.									
				PDC1200 35.5Ah			360 min.					
				PDC1500 43.55Ah			450 min.					
									10.8V Lithium-ion	BL1015K 1.5Ah		55 min.
									7.2V Lithium-ion	BL0715 1.5Ah		35 min.

Power Converter BAC01



Power converter powered by Makita portable power pack (BAC01 + PDC1200 / PDC1500)

The device, which converts DC power into AC power, is optimal for a wide range of applications.

AC output

50/60 Hz switchable with pure sine wave

Max output

Rating value for 4 seconds

2,800 W(VA)

Continuous rating output

1,400 W(VA)

Output port



AC output*3
x2



USB output
Type-A x2



USB output
Type-C x2



DC output
12V/10A
Cigar socket

*3 Output voltage and outlet shape vary depending on the country.

Portable Power Pack PDC1500 / PDC1200



PDC1500

Powered by 36V-40Vmax built-in battery
1,500Wh-class high capacity

IPX4

Charger: DC4001
Charging time: 450 min



PDC1200

Powered by 36V-40Vmax built-in battery
1,200 Wh high capacity

IPX4

Charger: DC4001
Charging time: 360 min



Battery Powered Models



UR101C
UR201C
UR202C



LM001C



UB003C



UB004C



VR001C

VR003C

VR004C



Adapter set



+

40Vmax
Li-Ion



Adapter set



+

36V
18V + 18V



Portable Power Pack

PDC1500

Capacity 43.55 Ah
Dimensions (L x W x H) w/o Harness: 369 x 312 x 131 mm (14-1/2 x 12-1/4 x 5-1/8")
w/ Harness: 516 x 312 x 193 mm (20-1/4 x 12-1/4 x 7-5/8")
Net weight 11.1 - 13.0 kg (24.5 - 28.7 lbs.)

PDC1200

Capacity 33.5 Ah
Dimensions (L x W x H) w/o Harness: 369 x 261 x 139 mm (14-1/2 x 10-1/4 x 5-1/2")
w/ Harness: 428 x 261 x 164 mm (16-7/8 x 10-1/4 x 6-1/2")
Net weight 8.8 kg (19.4 lbs.)

MAK TRAK™

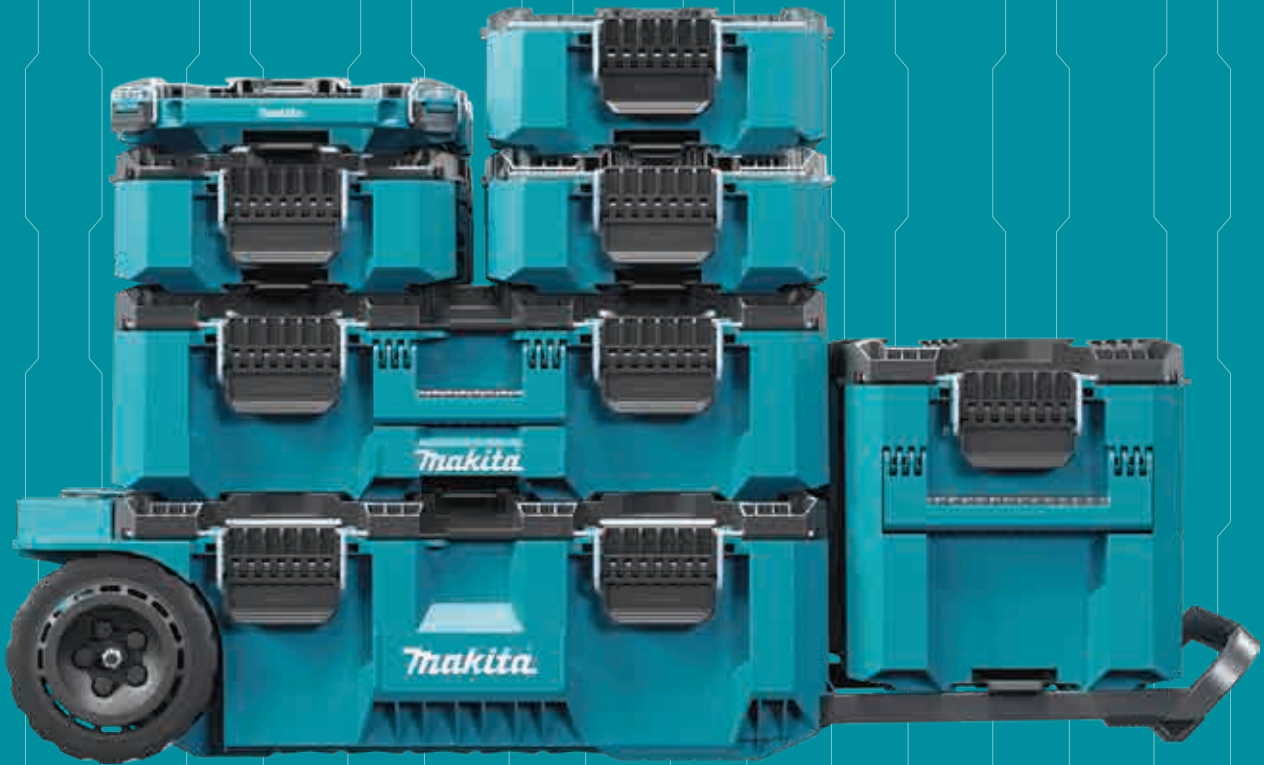

THE NEXT GENERATION IN MODULAR STORAGE SYSTEMS™

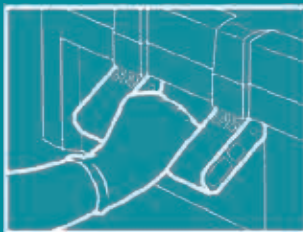

COMFORT-GRIP HANDLE



LARGE GLOVE FRIENDLY LATCH

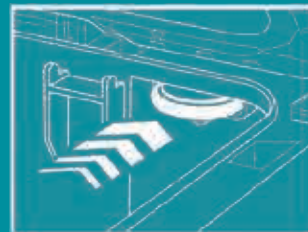

HIDDEN SECURITY TRACKER SLOT

MAKTRAK™

USERS ACROSS THE COUNTRY HAVE TOLD US ABOUT THEIR CHALLENGES WITH MANY OF THE CURRENT VERTICAL SYSTEMS

TRANSPORT

EFFICIENT LOADING AND UNLOADING



Premium handle with Gecko Grips™ provides efficient loading and unloading

ACCESS

OPEN ANY BOX WITHOUT UNSTACKING



Horizontal dual-hinged lid allows access to any case without unstacking or interference from the handle

STORE

SPACE FOR LARGER TOOLS AND ACCESSORIES



Horizontal design provides wider interior space for larger tools and accessories

ORGANISE

CUSTOMISE YOUR OWN CONFIGURATION



Customisable with lid mounting points, molle panel dividers, nested bins and battery/charger storage trays

WE LISTENED, AND WE ARE REDEFINING THE CATEGORY WITH A HORIZONTAL DESIGN



INNOVATION

GECKO GRIP™ RUBBERISED HANDLE FOR EASY TRUCK/VAN LOADING AND UNLOADING



CONVENIENCE

OPEN ANY BOX WITHOUT HANDLE INTERFERENCE OR UNSTACKING



SECURE

THE HORIZONTAL DESIGN FITS UNDER A TRUCK BED COVER FOR EASE OF TRANSPORT



DESIGN

HORIZONTAL DESIGN FOR MAXIMUM ACCESSIBILITY; FITS LONG TOOLS



Rolling Too Chest
T-90009 / P-91001



Large Tool Box
T-90015 / P-91017



Extra Large Tool Box
T-90021 / P-91023



Medium Tool Box
T-90037 / P-91039



Deep Medium Organiser
T-90043 / P-91045



Low-Profile Medium Organiser
T-90059 / P-91051



Deep Compact Organiser
T-90065 / P-91067



	T-90009 / P-91001	T-90015 / P-91017	T-90021 / P-91023	T-90037 / P-91039	T-90043 / P-91045	T-90059 / P-91051	T-90065 / P-91067
Max. Handle Length	387mm	-	-	-	-	-	-
Dimensions (HxWxD)	295 x 1011 x 565mm	252 x 802 x 565mm	402 x 394 x 565mm	161 x 387 x 562mm	163 x 387 x 562mm	85 x 387 x 596mm	162 x 278 x 389mm
Max Load Capacity	113kg	45kg	45kg	34kg	22.6kg	-	-
Volume Capacity	81.9L	63L	58.4L	18.4L	18.4L	8.14L	8.55L
Tool Box Weight	17.44kg	10.11kg	7.21kg	4.45kg	4.87kg	2.89kg	2.59kg
Includes	(1) 10" Molle Panel Divider (1) Large Storage Tray (1) Galvanised Strut	(1) Large Storage Tray (1) 8" Molle Panel Divider (1) Galvanised Strut	(1) X-Large Storage Tray	(2) Upper Deep Tray (2) Lower Shallow Tray	(8) standard deep bin (2) Medium Deep Bin (1) Organiser deep bin long	(8) Standard low profile (2) Medium low-pro bin (1) Low-profile Long bin	(4) Standard deep bin (2) Medium deep bin

MAKPAC

MAKPAC trolley

able to stack on for easy loading



MAKPAC adapter set

Makita AC Vacuum Cleaner to connect with MAKPAC

Model No.

VC001G,L VC002GL,
VC003GL, VC004GL,
VC005GL, VC3211H/M,
VC2211M, VC2201M,
VC1310L, VC2510L,
VC3210L



MAKPAC organizer

ideal for accessory cases

- MAKPAC organizer set
- MAKPAC organizer set (No box)



Cool Box

20mm thickness formed polystyrene, sealing strips are placed around the mating surface of lid and box.



Screwing/Drilling



Icon

- Double Insulation
- Variable Speed
- Brake
- Reversing
- Anti-restart function
- Mechanical 2-Speed
- Mechanical 3-Speed
- Electronic 2-Speed
- Electronic 3-Speed
- Electronic 4-Speed
- Keyless Chuck
- Torque Setting 6
- Torque Setting 9
- Torque Setting 16
- Torque Setting 18
- Torque Setting 20
- Torque Setting 21
- Clutch-equipped
- Torque Limiter
- Constant Speed
- Soft Start
- Built-in Job Light
- Carrying Case

Cordless Hammer Driver Drill / Cordless Driver Drill

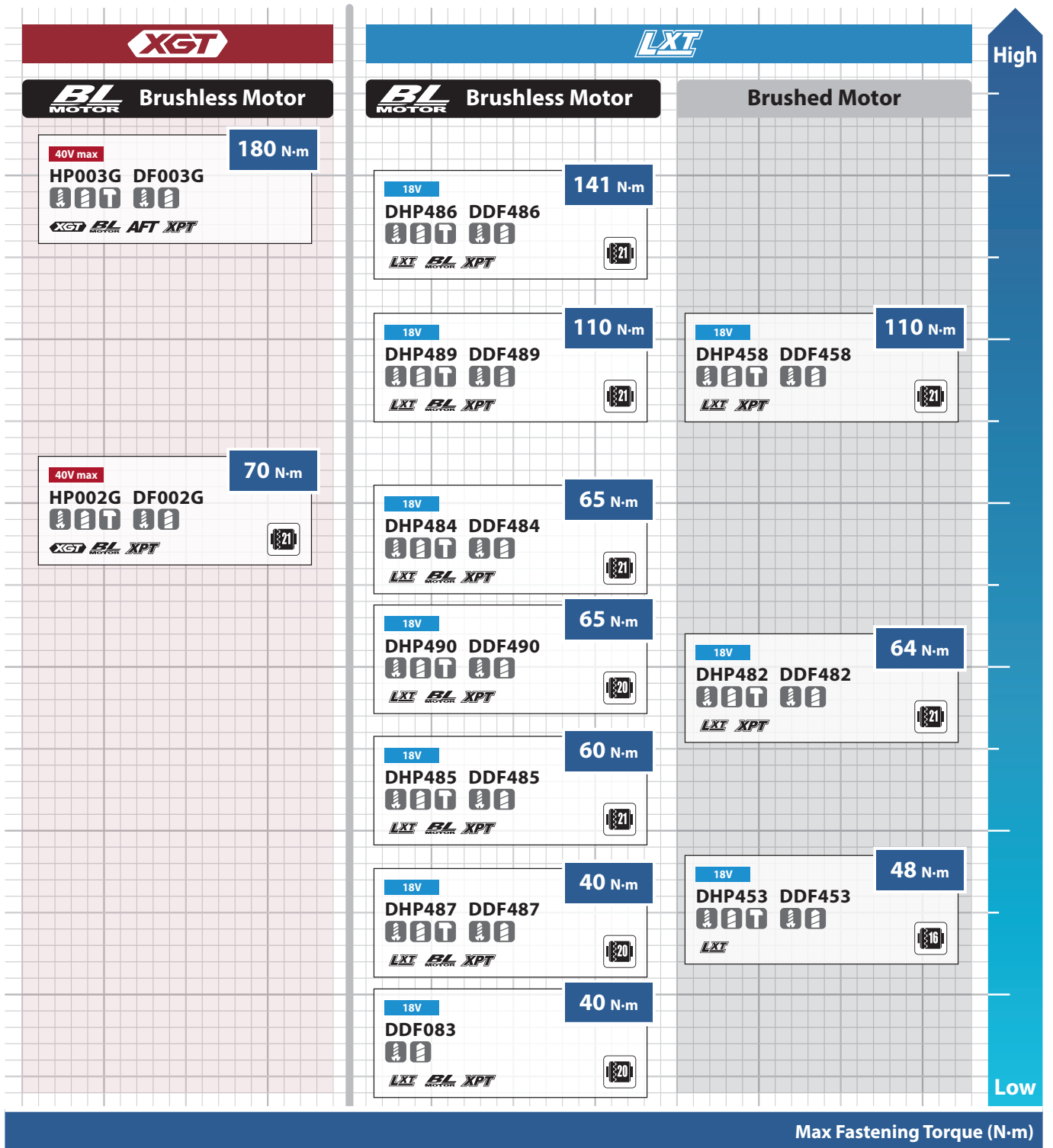

40Vmax XGT BL AFT Cordless 13 mm (1/2") 180 N-m (1,590 in.lbs) Driver Drill DF003G

40V max

new



No load speed	High: 0 - 2,400 min ⁻¹ Med.: 0 - 1,800 min ⁻¹ Low: 0 - 650 min ⁻¹
Capacity	Wood (Self-feed bit): 92 mm (3-5/8") Wood (Hole saw): 152 mm (6") Steel: 20 mm (13/16")
Max torque	180 N-m (1,590 in.lbs.)
Max fastening torque	Hard: 150 N-m (1,330 in.lbs.) Soft, High / Med. / Low: 28 / 36 / 88 N-m (250 / 320 / 780 in.lbs.)
Chuck capacity	13 mm (1/2")
Dimensions (L x W x H)	196 x 86 x 284 mm (7-3/4 x 3-3/8 x 11-1/8")
Net weight	2.8 - 4.0 kg (6.2 - 8.8 lbs.)

XGT BL AFT XPT



40Vmax XGT BL AFT Cordless 13 mm (1/2") 180 N-m (1,590 in.lbs) Hammer Driver Drill HP003G

40V max

new



No load speed	High: 0 - 2,400 min ⁻¹ / Med.: 0 - 1,800 min ⁻¹ Low: 0 - 650 min ⁻¹
Impacts per minute	High: 0 - 36,000 min ⁻¹ / Med.: 0 - 27,000 min ⁻¹ Low: 0 - 9,750 min ⁻¹
Capacity	Wood (Self-feed bit): 92 mm (3-5/8") Steel: 20 mm (13/16") Masonry: 20 mm (13/16")
Max torque	180 N-m (1,590 in.lbs.)
Max fastening torque	Hard: 150 N-m (1,330 in.lbs.) Soft, High / Med. / Low: 28 / 36 / 88 N-m (250 / 320 / 780 in.lbs.)
Chuck capacity	13 mm (1/2")
Dimensions (L x W x H)	197 x 86 x 284 mm (7-3/4 x 3-3/8 x 11-1/8")
Net weight	2.8 - 4.0 kg (6.2 - 8.8 lbs.)

XGT BL AFT XPT



40Vmax XGT BL Brushless Cordless 13 mm (1/2") 70 N-m (620 in.lbs) Driver Drill DF002G

40V max



No load speed	High: 0 - 2,200 min ⁻¹ Low: 0 - 600 min ⁻¹
Capacity	Wood (Self-feed bit): 38 mm (1-1/2") Wood (Hole saw): 51 mm (2") Steel: 13 mm (1/2")
Max torque	70 N-m (620 in.lbs)
Max fastening torque	Hard: 64 N-m (570 in.lbs.) Soft: 30 N-m (270 in.lbs.)
Chuck capacity	1.5 - 13 mm (1/16 - 1/2")
Dimensions (L x W x H)	w/ BL4050F: 164 x 86 x 294 mm (6-1/2 x 3-3/8 x 11-5/8")
Net weight	1.9 - 2.5 kg (4.2 - 5.5 lbs.)

XGT BL XPT



40Vmax XGT BL Brushless Cordless 13 mm (1/2") 70 N-m (620 in.lbs) Hammer Driver Drill HP002G

40V max



No load speed	High: 0 - 2,200 min ⁻¹ Low: 0 - 600 min ⁻¹
Impacts per minute	High: 0 - 33,000 min ⁻¹ Low: 0 - 9,000 min ⁻¹
Capacity	Wood (Self-feed bit): 38 mm (1-1/2") Steel: 13 mm (1/2") Masonry: 13 mm (1/2")
Max torque	70 N-m (620 in.lbs)
Max fastening torque	Hard: 64 N-m (570 in.lbs.) Soft: 30 N-m (270 in.lbs.)
Chuck capacity	1.5 - 13 mm (1/16 - 1/2")
Dimensions (L x W x H)	w/ BL4050F: 174 x 86 x 294 mm (6-7/8 x 3-3/8 x 11-5/8")
Net weight	2.0 - 2.6 kg (4.4 - 5.7 lbs.)

XGT BL XPT



18V LXT BL Brushless Cordless 13 mm (1/2") 141 N-m (1,250 in.lbs) Driver Drill DDF486

18V



No load speed	High: 0 - 2,100 min ⁻¹ Low: 0 - 550 min ⁻¹
Capacity	Wood (Self-feed bit): 76 mm (3") Steel: 20 mm (13/16") Wood (Auger-bit): 50 mm (2")
Max torque	141 N-m (1,250 in.lbs)
Max fastening torque	Hard: 130 N-m (1,150 in.lbs.) Soft: 65 N-m (580 in.lbs.)
Chuck capacity	1.5 - 13 mm (1/16 - 1/2")
Dimensions (L x W x H)	w/ BL1830B / BL1840B / BL1850B / BL1860B: 179 x 81 x 265 mm (7-1/16 x 3-3/16 x 10-3/8")
Net weight	2.3 - 2.6 kg (5.1 - 5.7 lbs.)

LXT BL XPT



18V LXT BL Brushless Cordless 13 mm (1/2") 141 N-m (1,250 in.lbs) Hammer Driver Drill DHP486

18V



No load speed	High: 0 - 2,100 min ⁻¹ Low: 0 - 550 min ⁻¹
Impacts per minute	High: 0 - 31,500 min ⁻¹ Low: 0 - 8,250 min ⁻¹
Capacity	Wood (Self-feed bit): 76 mm (3") Steel: 13 mm (1/2") Masonry: 16 mm (5/8")
Max torque	141 N-m (1,250 in.lbs)
Max fastening torque	Hard: 130 N-m (1,150 in.lbs.) Soft: 65 N-m (580 in.lbs.)
Chuck capacity	13 mm (1/2")
Dimensions (L x W x H)	178 x 81 x 265 mm (7 x 3-3/16 x 10-3/8")
Net weight	2.7 kg (6.0 lbs.)

LXT BL XPT



18V LXT BL Cordless 13 mm (1/2") 110 N-m (970 in.lbs) Driver Drill DDF489

18V



No load speed	High: 0 - 1,800 min ⁻¹ Low: 0 - 550 min ⁻¹
Capacity	Wood (Self-feed bit): 51 mm (2") Steel: 13 mm (1/2") Wood (Auger-bit): 38 mm (1-1/2")
Max torque	110 N-m (970 in.lbs)
Max fastening torque	Hard: 73 N-m (650 in.lbs.) Soft: 40 N-m (350 in.lbs.)
Chuck capacity	1.5 - 13 mm (1/16 - 1/2")
Dimensions (L x W x H)	174 x 81 x 261 mm (6-7/8 x 3-3/16 x 10-1/4")
Net weight	1.8 - 2.5 kg (4.0 - 5.5 lbs.)

LXT BL XPT



18V LXT BL Cordless 13 mm (1/2") 110 N-m (970 in.lbs) Hammer Driver Drill DHP489

18V



No load speed	High: 0 - 1,800 min ⁻¹ / Low: 0 - 550 min ⁻¹
Impacts per minute	High: 0 - 27,000 min ⁻¹ Low: 0 - 8,250 min ⁻¹
Capacity	Wood (Self-feed bit): 51 mm (2") Steel: 13 mm (1/2") Masonry: 16 mm (5/8") Wood: 38 mm (1-1/2")
Max torque	110 N-m (970 in.lbs)
Max fastening torque	Hard: 73 N-m (650 in.lbs.) Soft: 40 N-m (350 in.lbs.)
Chuck capacity	13 mm (1/2")
Dimensions (L x W x H)	175 x 81 x 261 mm (6-7/8 x 3-3/16 x 10-1/4")
Net weight	1.8 - 2.5 kg (4.0 - 5.5 lbs.)

LXT BL XPT



18V LXT BL Brushless Cordless 13 mm (1/2") 65 N-m (580 in.lbs) Driver Drill DDF484

18V



No load speed	High: 0 - 2,000 min ⁻¹ Low: 0 - 500 min ⁻¹
Capacity	Wood (Self-feed bit): 76 mm (3") Steel: 13 mm (1/2") Wood (Auger-bit): 38 mm (1-1/2") Wood: 38 mm (1-1/2")
Max torque	65 N-m (580 in.lbs)
Max fastening torque	Hard: 54 N-m (480 in.lbs.) Soft: 30 N-m (270 in.lbs.)
Chuck capacity	1.5 - 13 mm (1/16 - 1/2")
Dimensions (L x W x H)	162 or 172 x 79 x 261 mm (6-3/8 or 6-3/4 x 3-1/8 x 10-1/4")
Net weight	1.5 - 2.2 kg (3.3 - 4.9 lbs.)

LXT BL XPT



18V LXT BL Brushless Cordless 13 mm (1/2") 65 N-m (580 in.lbs) Hammer Driver Drill DHP484

18V



No load speed	High: 0 - 2,000 min ⁻¹ / Low: 0 - 500 min ⁻¹
Impacts per minute	High: 0 - 30,000 min ⁻¹ Low: 0 - 7,500 min ⁻¹
Capacity	Wood (Self-feed bit): 38 mm (1-1/2") Steel: 13 mm (1/2") Masonry: 13 mm (1/2") Wood: 38 mm (1-1/2")
Max torque	65 N-m (580 in.lbs)
Max fastening torque	Hard: 54 N-m (480 in.lbs.) Soft: 30 N-m (270 in.lbs.)
Chuck capacity	13 mm (1/2")
Dimensions (L x W x H)	172 or 182 x 79 x 261 mm (6-3/4 or 7-1/8 x 3-1/8 x 10-1/4")
Net weight	1.6 - 2.2 kg (3.5 - 4.9 lbs.)

LXT BL XPT



Screwing/Drilling

18V LXT Brushless Cordless 13 mm (1/2") 65 N-m (580 in.lbs) Driver Drill

DDF490

18V

new



No load speed	High: 0 - 1,900 min ⁻¹ Low: 0 - 500 min ⁻¹
Capacity	Steel: 13 mm (1/2") Wood: 38 mm (1-1/2")
Max torque	65 N-m (580 in.lbs)
Max fastening torque	Hard: 50 N-m (440 in.lbs.) Soft: 27 N-m (240 in.lbs.)
Chuck capacity	13 mm (1/2")
Dimensions (L x W x H)	167 x 81 x 237 mm (6-9/16 x 3-3/16 x 9-3/8")
Net weight	1.4 - 1.7 kg (3.1 - 3.7 lbs.)

LXT BL MOTOR XPT



18V LXT Brushless Cordless 13 mm (1/2") 65 N-m (580 in.lbs) Hammer Driver Drill

DHP490

18V

new



No load speed	High: 0 - 1,900 min ⁻¹ Low: 0 - 500 min ⁻¹
Impacts per minute	High: 0 - 28,500 min ⁻¹ Low: 0 - 7,500 min ⁻¹
Capacity	Steel: 13 mm (1/2") Masonry: 13 mm (1/2") Wood: 38 mm (1-1/2")
Max torque	65 N-m (580 in.lbs)
Max fastening torque	Hard: 50 N-m (440 in.lbs.) Soft: 27 N-m (240 in.lbs.)
Chuck capacity	13 mm (1/2")
Dimensions (L x W x H)	172 x 81 x 237 mm (6-3/4 x 3-3/16 x 9-3/8")
Net weight	1.4 - 1.7 kg (3.1 - 3.7 lbs.)

LXT BL MOTOR XPT



18V LXT BL Brushless Cordless 13 mm (1/2") 60 N-m (530 in.lbs) Driver Drill

DDF485

18V



No load speed	High: 0 - 1,900 min ⁻¹ Low: 0 - 500 min ⁻¹
Capacity	Wood (Self-feed bit): 76 mm (3") Steel: 13 mm (1/2") Wood (Auger-bit): 38 mm (1-1/2") Wood: 38 mm (1-1/2")
Max torque	65 N-m (575 in.lbs)
Max fastening torque	Hard: 50 N-m (440 in.lbs.) Soft: 27 N-m (240 in.lbs.)
Chuck capacity	1.5 - 13 mm (1/16 - 1/2")
Dimensions (L x W x H)	169 x 79 x 237 mm (6-5/8 x 3-1/8 x 9-3/8")
Net weight	1.4 - 1.7 kg (3.1 - 3.7 lbs.)

LXT BL MOTOR XPT



18V LXT BL Brushless Cordless 13 mm (1/2") 60 N-m (530 in.lbs) Hammer Driver Drill

DHP485

18V



No load speed	High: 0 - 1,900 min ⁻¹ / Low: 0 - 500 min ⁻¹
Impacts per minute	High: 0 - 28,500 min ⁻¹ Low: 0 - 7,500 min ⁻¹
Capacity	Wood (Self-feed bit): 38 mm (1-1/2") Steel: 13 mm (1/2") Masonry: 13 mm (1/2") Wood: 38 mm (1-1/2")
Max torque	60 N-m (530 in.lbs)
Max fastening torque	Hard: 50 N-m (440 in.lbs.) Soft: 27 N-m (240 in.lbs.)
Chuck capacity	13 mm (1/2")
Dimensions (L x W x H)	182 x 79 x 237 mm (7-1/8 x 3-1/8 x 9-3/8")
Net weight	1.5 - 1.8 kg (3.3 - 4.0 lbs.)

LXT BL MOTOR XPT



18V LXT BL Brushless Cordless 13 mm (1/2") 40 N-m (350 in.lbs.) Driver Drill

DDF487

18V



No load speed	High: 0 - 1,700 min ⁻¹ Low: 0 - 500 min ⁻¹
Capacity	Wood (Self-feed bit): 35 mm (1-3/8") Steel: 13 mm (1/2") Wood (Auger-bit): 36 mm (1-7/16")
Max torque	40 N-m (350 in.lbs)
Max fastening torque	Hard: 40 N-m (350 in.lbs.) Soft: 25 N-m (220 in.lbs.)
Chuck capacity	1.5 - 13 mm (1/16 - 1/2")
Dimensions (L x W x H)	w/ BL1830B / BL1840B / BL1850B / BL1860B: 150 x 81 x 248 mm (5-7/8 x 3-3/16 x 9-3/4")
Net weight	1.3 - 1.6 kg (2.9 - 3.5 lbs.)

LXT BL MOTOR XPT



18V LXT BL Brushless Cordless 13 mm (1/2") 40 N-m (350 in.lbs.) Hammer Driver Drill

DHP487

18V



No load speed	High: 0 - 1,700 min ⁻¹ Low: 0 - 500 min ⁻¹
Impacts per minute	High: 0 - 25,500 min ⁻¹ Low: 0 - 7,500 min ⁻¹
Capacity	Wood (Self-feed bit): 35 mm (1-3/8") Steel: 13 mm (1/2") Masonry: 13 mm (1/2")
Max torque	40 N-m (350 in.lbs)
Max fastening torque	Hard: 40 N-m (350 in.lbs.) Soft: 25 N-m (220 in.lbs.)
Dimensions (L x W x H)	w/ BL1830B / BL1840B / BL1850B / BL1860B: 164 x 81 x 248 mm (6-1/2 x 3-3/16 x 9-3/4")
Net weight	1.4 - 1.7 kg (3.1 - 3.7 lbs.)

LXT BL MOTOR XPT



18V LXT Li-Ion Cordless 13 mm (1/2") 110 N-m (970 in.lbs) Driver Drill

DDF458

18V



No load speed	High: 0 - 2,000 min ⁻¹ Low: 0 - 400 min ⁻¹
Capacity	Wood (Self-feed bit): 92 mm (3-5/8") Steel: 13 mm (1/2") Wood: 76 mm (3")
Max torque	110 N-m (970 in.lbs)
Max fastening torque	Hard: 91 N-m (810 in.lbs.) Soft: 58 N-m (520 in.lbs.)
Chuck capacity	1.5 - 13 mm (1/16 - 1/2")
Dimensions (L x W x H)	225 x 79 x 259 mm (8-7/8 x 3-1/8 x 10-1/4")
Net weight	2.1 - 2.5 kg (4.7 - 5.4 lbs.)

LXT XPT



18V LXT Li-Ion Cordless 13 mm (1/2") 110 N-m (970 in.lbs) Hammer Driver Drill

DHP458

18V



No load speed	High: 0 - 2,000 min ⁻¹ / Low: 0 - 400 min ⁻¹
Impacts per minute	High: 0 - 30,000 min ⁻¹ Low: 0 - 6,000 min ⁻¹
Capacity	Wood (Self-feed bit): 76 mm (3") Steel: 13 mm (1/2") Masonry: 16 mm (5/8") Wood: 76 mm (3")
Max torque	110 N-m (970 in.lbs)
Max fastening torque	Hard: 91 N-m (810 in.lbs.) Soft: 58 N-m (520 in.lbs.)
Chuck capacity	1.5 - 13 mm (1/16 - 1/2")
Dimensions (L x W x H)	225 x 79 x 259 mm (8-7/8 x 3-1/8 x 10-1/4")
Net weight	2.2 - 2.6 kg (4.9 - 5.7 lbs.)

LXT XPT



18V LXT Li-Ion Cordless 13 mm (1/2") 3-Speed 63 N-m (560 in.lbs.) Driver Drill

DDF451

18V



No load speed	3rd: 0 - 1,700 min ⁻¹ 2nd: 0 - 600 min ⁻¹ 1st: 0 - 300 min ⁻¹
Capacity	Wood (Self-feed bit): 92 mm (3-5/8") Steel: 13 mm (1/2") Wood: 65 mm (2-9/16")
Max torque	63 N-m (560 in.lbs)
Max fastening torque	Hard: 80 N-m (708 in.lbs.) Soft: 40 N-m (354 in.lbs.)
Chuck capacity	1.5 - 13 mm (1/16 - 1/2")
Dimensions (L x W x H)	238 x 78 x 257 mm (9-3/8 x 3-1/16 x 10-1/8")
Net weight	2.3 - 2.6 kg (5 - 5.7 lbs.)

LXT



18V LXT Li-Ion Cordless 13 mm (1/2") 3-Speed 63 N-m (560 in.lbs.) Hammer Driver Drill

DHP451

18V



No load speed	High: 0 - 1,700 min ⁻¹ / Med.: 0 - 600 min ⁻¹ Low: 0 - 300 min ⁻¹
Impacts per minute	High: 0 - 25,500 min ⁻¹ / Med.: 0 - 9,000 min ⁻¹ Low: 0 - 4,500 min ⁻¹
Capacity	Wood (Self-feed bit): 65 mm (2-9/16") Steel: 13 mm (1/2") Masonry: 16 mm (5/8") Wood: 65 mm (2-9/16")
Max torque	63 N-m (560 in.lbs)
Max fastening torque	Hard: 80 N-m (708 in.lbs.) Soft: 40 N-m (354 in.lbs.)
Chuck capacity	1.5 - 13 mm (1/16 - 1/2")
Dimensions (L x W x H)	250 x 78 x 257 mm (9-7/8 x 3-1/16 x 10-1/8")
Net weight	2.5 - 2.9 kg (5.6 - 6.3 lbs.)

LXT



18V LXT Li-Ion Cordless 13 mm (1/2") 64 N-m (570 in.lbs) Driver Drill

DDF482

18V



No load speed	High: 0 - 1,900 min ⁻¹ Low: 0 - 600 min ⁻¹
Capacity	Wood (Self-feed bit): 60 mm (2-3/8") Steel: 13 mm (1/2") Wood (Auger-bit): 38 mm (1-1/2")
Max torque	64 N-m (570 in.lbs)
Max fastening torque	Hard: 62 N-m (550 in.lbs.) Soft: 36 N-m (320 in.lbs.)
Chuck capacity	1.5 - 13 mm (1/16 - 1/2")
Dimensions (L x W x H)	185 x 79 x 249 mm (7-1/4 x 3-1/8 x 9-3/4")
Net weight	1.5 - 1.8 kg (3.2 - 4 lbs.)

LXT XPT



18V LXT Li-Ion Cordless 13 mm (1/2") 64 N-m (570 in.lbs) Hammer Driver Drill

DHP482

18V



No load speed	High: 0 - 1,900 min ⁻¹ / Low: 0 - 600 min ⁻¹
Impacts per minute	High: 0 - 28,500 min ⁻¹ Low: 0 - 9,000 min ⁻¹
Capacity	Wood (Self-feed bit): 51 mm (2") Steel: 13 mm (1/2") Masonry: 13 mm (1/2") Wood: 38 mm (1-1/2")
Max torque	64 N-m (570 in.lbs)
Max fastening torque	Hard: 62 N-m (550 in.lbs.) Soft: 36 N-m (320 in.lbs.)
Chuck capacity	1.5 - 13 mm (1/16 - 1/2")
Dimensions (L x W x H)	198 x 79 x 249 mm (7-3/4 x 3-1/8 x 9-3/4")
Net weight	1.5 - 1.8 kg (3.4 - 4.1 lbs.)

LXT XPT



18V LXT Li-Ion Cordless 13 mm (1/2") 48 N-m (420 in.lbs) Driver Drill

DDF453

18V



No load speed	High: 0 - 1,300 min ⁻¹ Low: 0 - 400 min ⁻¹
Capacity	Wood (Self-feed bit): 72 mm (2-13/16") Steel: 13 mm (1/2") Wood: 36 mm (1-7/16")
Max torque	48 N-m (420 in.lbs)
Max fastening torque	Hard: 42 N-m (372 in.lbs.) Soft: 27 N-m (239 in.lbs.)
Chuck capacity	1.5 - 13 mm (1/16 - 1/2")
Dimensions (L x W x H)	222 x 79 x 244 mm (8-3/4 x 3-1/8 x 9-5/8")
Net weight	1.7 - 2 kg (3.7 - 4.4 lbs.)

LXT



18V LXT Li-Ion Cordless 13 mm (1/2") 48 N-m (420 in.lbs) Hammer Driver Drill

DHP453

18V



No load speed	High: 0 - 1,300 min ⁻¹ Low: 0 - 400 min ⁻¹
Impacts per minute	High: 0 - 19,500 min ⁻¹ Low: 0 - 6,000 min ⁻¹
Capacity	Wood (Self-feed bit): 38 mm (1-1/2") Steel: 13 mm (1/2") Masonry: 13 mm (1/2") Wood: 36 mm (1-7/16")
Max torque	48 N-m (420 in.lbs)
Max fastening torque	Hard: 42 N-m (372 in.lbs.) Soft: 27 N-m (239 in.lbs.)
Chuck capacity	1.5 - 13 mm (1/16 - 1/2")
Dimensions (L x W x H)	240 x 79 x 244 mm (9-7/16 x 3-1/8 x 9-5/8")
Net weight	1.7 - 2 kg (3.6 - 4.4 lbs.)

LXT



18V LXT BL Brushless Cordless 6.35 mm (1/4") Hex 40 N-m (350 in.lbs.) Driver Drill

DDF083

18V



No load speed	High: 0 - 1,700 min ⁻¹ Low: 0 - 500 min ⁻¹
Capacity	Wood (Self-feed bit): 72 mm (2-13/16") Steel: 13 mm (1/2") Wood: 36 mm (1-7/16")
Max torque	40 N-m (350 in.lbs)
Max fastening torque	Hard: 40 N-m (350 in.lbs.) Soft: 23 N-m (210 in.lbs.)
Chuck capacity	6.35 mm (1/4")
Dimensions (L x W x H)	124 x 79 x 247 mm (4-7/8 x 3-1/8 x 9-3/4")
Net weight	1.1 - 1.4 kg (2.4 - 3 lbs.)

LXT BL MOTOR XPT



12Vmax CXT BL Brushless Cordless 6.35 mm (1/4") Hex 38 N-m (340 in.lbs) Driver Drill

DF032D

12V max



No load speed	High: 0 - 1,500 min ⁻¹ Low: 0 - 450 min ⁻¹
Capacity	Wood (Self-feed bit): 56 mm (2-3/16") Steel: 10 mm (3/8") Wood: 28 mm (1-1/8")
Max torque	38 N-m (340 in.lbs)
Max fastening torque	Hard: 35 N-m (310 in.lbs.) Soft: 21 N-m (190 in.lbs.)
Chuck capacity	6.35 mm (1/4")
Dimensions (L x W x H)	124 x 66 x 217 mm (4-7/8 x 2-5/8 x 8-1/2")
Net weight	0.88 - 1 kg (1.9 - 2.3 lbs.)

CXT BL MOTOR XPT



12Vmax CXT BL Brushless Cordless 10 mm (3/8") 38 N-m (340 in.lbs) Driver Drill

DF332D

12V max



No load speed	High: 0 - 1,500 min ⁻¹ Low: 0 - 450 min ⁻¹
Capacity	Wood (Self-feed bit): 56 mm (2-3/16") Steel: 10 mm (3/8") Wood: 28 mm (1-1/8")
Max torque	38 N-m (340 in.lbs)
Max fastening torque	Hard: 35 N-m (310 in.lbs.) Soft: 21 N-m (190 in.lbs.)
Chuck capacity	0.8 - 10 mm (1/32 - 3/8")
Dimensions (L x W x H)	154 x 66 x 217 mm (6-1/16 x 2-5/8 x 8-1/2")
Net weight	1 - 1.2 kg (2.3 - 2.6 lbs.)

CXT BL MOTOR XPT



12V max CXT BL Brushless Cordless 10 mm (3/8") 38 N-m (340 in.lbs) Hammer Driver Drill

HP332D

12V max



No load speed	High: 0 - 1,500 min ⁻¹ Low: 0 - 450 min ⁻¹
Impacts per minute	High: 0 - 22,500 min ⁻¹ Low: 0 - 6,750 min ⁻¹
Capacity	Steel: 10 mm (3/8") Masonry: 8 mm (5/16") Wood: 28 mm (1-1/8")
Max torque	38 N-m (340 in.lbs)
Max fastening torque	Hard: 35 N-m (310 in.lbs.) Soft: 21 N-m (190 in.lbs.)
Chuck capacity	0.8-10 mm (1/32-3/8")
Dimensions (L x W x H)	168 x 66 x 217 mm (6-5/8 x 2-5/8 x 8-1/2")
Net weight	1.1 - 1.3 kg (2.4 - 2.8 lbs.)

CXT BL MOTOR XPT



12Vmax CXT Li-Ion Cordless 10 mm (3/8") 34 N-m (300 in.lbs) Driver Drill

DF333D

12V max



No load speed	High: 0 - 1,700 min ⁻¹ Low: 0 - 450 min ⁻¹
Capacity	Wood (Self-feed bit): 42 mm (1-5/8") Steel: 10 mm (3/8") Wood: 21 mm (13/16")
Max torque	34 N-m (300 in.lbs)
Max fastening torque	Hard: 30 N-m (270 in.lbs.) Soft: 14 N-m (130 in.lbs.)
Chuck capacity	0.8 - 10 mm (1/32 - 3/8")
Dimensions (L x W x H)	w/ BL1041B: 179 x 66 x 229 mm (7 x 2-5/8 x 9")
Net weight	1.1 - 1.2 kg (2.4 - 2.7 lbs.)

CXT



12Vmax CXT Li-Ion Cordless 10 mm (3/8") 34 N-m (300 in.lbs) Hammer Driver Drill

HP333D

12V max



No load speed	High: 0 - 1,700 min ⁻¹ Low: 0 - 450 min ⁻¹
Impacts per minute	High: 0 - 25,500 min ⁻¹ Low: 0 - 6,750 min ⁻¹
Capacity	Steel: 10 mm (3/8") Masonry: 8 mm (5/16") Wood: 21 mm (13/16")
Max torque	34 N-m (300 in.lbs)
Max fastening torque	Hard: 30 N-m (270 in.lbs.) Soft: 14 N-m (130 in.lbs.)
Chuck capacity	0.8 - 10 mm (1/32 - 3/8")
Dimensions (L x W x H)	w/ BL1041B: 193 x 66 x 229 mm (7-5/8 x 2-5/8 x 9")
Net weight	1.1 - 1.3 kg (2.4 - 2.9 lbs.)

CXT



Screwing/Drilling

12Vmax CXT Li-Ion Cordless 6.35 mm (1/4") Hex 34 N-m (300 in.lbs) Driver Drill

DF033D

12V max



No load speed	High: 0 - 1,700 min ⁻¹ Low: 0 - 450 min ⁻¹
Capacity	Wood (Self-feed bit): 42 mm (1-5/8") Steel: 10 mm (3/8") Wood: 21 mm (13/16")
Max torque	34 N-m (300 in.lbs)
Max fastening torque	Hard: 30 N-m (270 in.lbs.) Soft: 14 N-m (130 in.lbs.)
Chuck capacity	6.35 mm (1/4")
Dimensions (L x W x H)	w/ BL1041B: 149 x 66 x 229 mm (5-7/8 x 2-5/8 x 9")
Net weight	0.9 - 1.1 kg (2.1 - 2.4 lbs.)



10.8V (12V max) Li-Ion Cordless 6.35 mm (1/4") Hex 28 N-m (250 in.lbs) Driver Drill

DF030D

10.8V



No load speed	High: 0 - 1,300 min ⁻¹ Low: 0 - 350 min ⁻¹
Capacity	Wood (Self-feed bit): 42 mm (1-5/8") Steel: 10 mm (3/8") Wood: 21 mm (13/16")
Max torque	28 N-m (250 in.lbs)
Max fastening torque	Hard: 24 N-m (210 in.lbs.) Soft: 14 N-m (120 in.lbs.)
Chuck capacity	6.35 mm (1/4")
Dimensions (L x W x H)	157 x 53 x 183 mm (6-3/16 x 2-1/16 x 7-1/4")
Net weight	0.88 kg (1.9 lbs.)



10.8V (12V max) Li-Ion Cordless 10 mm (3/8") 28 N-m (250 in.lbs) Driver Drill

DF330D

10.8V



No load speed	High: 0 - 1,300 min ⁻¹ Low: 0 - 400 min ⁻¹
Capacity	Wood (Self-feed bit): 42 mm (1-5/8") Steel: 10 mm (3/8") Wood: 21 mm (13/16")
Max torque	28 N-m (250 in.lbs)
Max fastening torque	Hard: 24 N-m (210 in.lbs.) Soft: 14 N-m (120 in.lbs.)
Chuck capacity	0.8 - 10 mm (1/32 - 3/8")
Dimensions (L x W x H)	189 x 53 x 183 mm (7-7/16 x 2-1/16 x 7-1/4")
Net weight	1 kg (2.2 lbs.)



10.8V (12V max) Li-Ion Cordless 10 mm (3/8") 28 N-m (250 in.lbs) Hammer Driver Drill

HP330D

10.8V



No load speed	High: 0 - 1,500 min ⁻¹ Low: 0 - 400 min ⁻¹
Impacts per minute	High: 0 - 22,500 min ⁻¹ Low: 0 - 6,000 min ⁻¹
Capacity	Steel: 10 mm (3/8") Masonry: 8 mm (5/16") Wood: 21 mm (13/16")
Max torque	28 N-m (250 in.lbs)
Max fastening torque	Hard: 24 N-m (210 in.lbs.) Soft: 14 N-m (124 in.lbs.)
Chuck capacity	0.8-10 mm (1/32-3/8")
Dimensions (L x W x H)	201 x 53 x 183 mm (7-7/8 x 2-1/16 x 7-1/4")
Net weight	1.1 kg (2.3 lbs.)



7.2V Li-Ion Cordless Two-Position 5 mm (3/16") 11 N-m (97 in.lbs) Driver Drill

DF012D

7.2V



No load speed	High: 650 min ⁻¹ Low: 200 min ⁻¹
Capacity	Wood (Self-feed bit): 12 mm (15/32") Steel: 5 mm (3/16") Wood: 6 mm (1/4")
Max torque	11 N-m (97 in.lbs)
Max fastening torque	Hard: 5.6 N-m (50 in.lbs.) Soft: 3.6 N-m (32 in.lbs.)
Chuck capacity	6.35 mm (1/4")
Dimensions (L x W x H)	Pistol Style: 218 x 44 x 142 mm (8-5/8 x 1-3/4 x 5-5/8")
Dimensions (L x W)	Straight style: 273 x 44 mm (10-3/4 x 1-3/4")
Net weight	0.53 kg (1.2 lbs.)



3.6V Li-Ion In-Line Cordless 9 N-m (80 in.lbs) Screwdriver, Built-In Battery

DF001D

3.6V



No load speed	220 min ⁻¹
Max fastening torque	Hard / Soft: 4.0 / 3.0 N-m (35 / 27 in.lbs.) 9 N-m (80 in.lbs)
Max torque	9 N-m (80 in.lbs)
Fastening capacities	Wood screw: Dia. 3.8 x 32 mm (1/8 x 1-1/4")
Dimensions (L x W x H)	Straight style: 287 x 47 x 51 mm (11-1/4 x 1-7/8 x 2") Pistol style: 205 x 47 x 51 mm (8-1/8 x 1-7/8 x 2")
Net weight	0.36 kg (0.79 lbs.)



14.4V Li-Ion Cordless 10 mm (3/8") 34 N-m (300 in.lbs) Driver Drill, G-Battery

DF347D

14.4V



No load speed	High: 0 - 1,400 min ⁻¹ Low: 0 - 400 min ⁻¹
Capacity	Steel: 10 mm (3/8") Wood: 25 mm (1")
Max torque	34 N-m (300 in.lbs)
Max fastening torque	Hard: 30 N-m Soft: 15 N-m
Chuck capacity	10 mm (3/8")
Dimensions (L x W x H)	198 x 83 x 235 mm (7-3/4 x 3-1/4 x 9-1/4")
Net weight	1.4 kg (3.2 lbs.)



14.4V Li-Ion Cordless 10 mm (3/8") 34 N-m (300 in.lbs) Hammer Driver Drill, G-Battery

HP347D

14.4V



No load speed	High: 0 - 1,400 min ⁻¹ Low: 0 - 400 min ⁻¹
Impacts per minute	High: 0 - 21,000 min ⁻¹ Low: 0 - 6,000 min ⁻¹
Capacity	Steel: 10 mm (3/8") Masonry: 10 mm (3/8") Wood: 25 mm (1")
Max torque	34 N-m (300 in.lbs)
Max fastening torque	Hard: 30 N-m (270 in.lbs.) Soft: 15 N-m (130 in.lbs.)
Chuck capacity	0.8-10 mm (1/32-3/8")
Dimensions (L x W x H)	216 x 83 x 235 mm (8-1/2 x 3-1/4 x 9-1/4")
Net weight	1.4 kg (3.1 lbs.)



10 mm (3/8") 320 W Driver Drill with Keyless Chuck

DF0300



Continuous rating Input	320W
No load speed	High: 0 - 1,500 min ⁻¹ Low: 0 - 450 min ⁻¹
Capacity	Steel: 10 mm (3/8") Wood: 28 mm (1-1/8")
Max torque	74 N-m (650 in.lbs)
Max fastening torque	Hard / Soft: 56.0 / 21.0 N-m (500 / 190 in.lbs.)
Chuck capacity	1.0 - 10 mm (1/32 - 3/8")
Dimensions (L x W x H)	220 x 67 x 206 mm (8-5/8 x 2-5/8 x 8-1/8")
Net weight	1.2 kg (2.7 lbs.)



10 mm (3/8") 320 W Hammer Driver Drill with Keyless Chuck

HP0300



Continuous rating Input	320W
No load speed	High: 0-1,500 min ⁻¹ / Low: 0-450 min ⁻¹
Capacity	Concrete: 8 mm (5/16") Steel: 10 mm (3/8") Wood: 28 mm (1-1/8")
Blows per minute	High: 0-22,500 min ⁻¹ Low: 0-6,750 min ⁻¹
Max torque	74 N-m (650 in.lbs)
Max fastening torque	Hard / Soft: 56.0 / 21.0 N-m (500 / 190 in.lbs.)
Chuck capacity	1.0-10 mm (1/32-3/8")
Dimensions (L x W x H)	235 x 67 x 206 mm (9-1/4 x 2-5/8 x 8-1/8")
Net weight	1.3 kg (2.8 lbs.)



Cordless Impact Driver

Screwing/
Drilling

High

Low

XGT

40V max **BL MOTOR**
230 N·m

TD004G

XGT XPT

+

4 stage power selection + 1 Assist mode (1 Tek)

40V max **BL MOTOR**
220 N·m

TD001G TD002G

XGT XPT

+

4 stage power selection + 6 Assist mode (Wood/3 Bolt/2 Tek)

40V max **BL MOTOR**
210 N·m

TD003G

XGT XPT

+

4 stage power selection + 1 Assist mode (1 Tek)

LXT

18V **BL MOTOR**
210 N·m

DTD201

LXT XPT

+

4 stage power selection + Teks mode

18V **BL MOTOR**
180 N·m

DTD173

LXT XPT

+

4 stage power selection + 4 Assist mode (Wood/Bolt/2 Tek)

18V **BL MOTOR**
170 N·m

DTD153

LXT XPT

18V
165 N·m

DTD152

LXT XPT

Brushed Motor

18V
155 N·m

DTD156

LXT

Brushed Motor

18V **BL MOTOR**
140 N·m

DTD157

LXT XPT

+

2 stage power selection + Assist mode

Assist mode

helps to eliminate "screw cam-out" and "cross threading" by driving at low speed until the start of tightening.

rpm vs second

Teks mode

"Teks" mode is a special mode optimum for fast tightening of self drilling screws without damaging the screw and the workpiece.

Max Fastening Torque (N·m)

Cordless Oil-Pulse Driver

18V
40 N·m

DTS141

LXT BL XPT

+

3 stage power selection + Teks mode

SOFT
IMPACT

Low Noise 77dB

Suitable for noise sensitive job site

Cordless 4 Mode Impact Driver

18V
150 N·m

DTP141

LXT BL MOTOR

+

3 stage power selection + Teks mode



- 4 Operation modes**
- Impact driver
 - Hammer drill
 - Drill
 - Screwdriver

40Vmax XGT BL Cordless T-Mode 230 N-m (2,040 in.lbs.) Impact Driver

TD004G

40V max



Capacity	Machine screw: M4 - M8 mm (5/32 - 5/16") Coarse thread (in length): 22 - 150 mm (7/8 - 5-7/8")
Max fastening torque	230 N-m (2,040 in.lbs.)
No load speed	Max / Hard / Med. / Soft: 0 - 3,900 / 0 - 3,000 / 0 - 2,100 / 0 - 1,200 min ⁻¹
Impacts per minute	Max / Hard / Med. / Soft: 0 - 3,900 / 0 - 3,600 / 0 - 3,100 / 0 - 1,900 min ⁻¹
Dimensions (L x W x H)	136 x 86 x 248 mm (5-3/8 x 3-3/8 x 9-3/4")
Net weight	1.8 - 3.1 kg (4.0 - 6.8 lbs.)



40Vmax XGT BL Brushless Cordless Wood/Bolt/T-Mode 220 N-m (1,950 in.lbs.) Impact Driver

TD002G

40V max



Capacity	Machine screw: M4 - M8 (5/32 - 5/16") Coarse thread (in length): 22 - 125 mm (7/8 - 4-7/8")
Max fastening torque	220 N-m (1,950 in.lbs.)
Fastening torque	Hard / Med. / Soft: 170 / 50 / 20 N-m (1,510 / 440 / 180 in.lbs.)
No load speed	Max / Hard / Med. / Soft: 0 - 3,700 / 0 - 3,200 / 0 - 2,100 / 0 - 1,100 min ⁻¹
Impacts per minute	Max / Hard / Med. / Soft: 0 - 4,600 / 0 - 3,600 / 0 - 2,600 / 0 - 1,400 min ⁻¹
Dimensions (L x W x H)	130 x 86 x 247 mm (5-1/8 x 3-3/8 x 9-3/4")
Net weight	1.7 - 2.9 kg (3.7 - 6.4 lbs.)



40Vmax XGT BL Brushless Cordless Wood/Bolt/T-Mode 220 N-m (1,950 in.lbs.) Impact Driver

TD001G

40V max



Capacity	Machine screw: M4 - M8 (5/32 - 5/16") Coarse thread (in length): 22 - 125 mm (7/8 - 4-7/8")
Max fastening torque	220 N-m (1,950 in.lbs.)
Fastening torque	Hard / Med. / Soft: 170 / 50 / 20 N-m (1,510 / 440 / 180 in.lbs.)
No load speed	Max / Hard / Med. / Soft: 0 - 3,700 / 0 - 3,200 / 0 - 2,100 / 0 - 1,100 min ⁻¹
Impacts per minute	Max / Hard / Med. / Soft: 0 - 4,400 / 0 - 3,600 / 0 - 2,600 / 0 - 1,100 min ⁻¹
Dimensions (L x W x H)	120 x 86 x 245 mm (4-3/4 x 3-3/8 x 9-5/8")
Net weight	1.7 kg (3.7 lbs.)



40Vmax XGT BL Cordless T-Mode 210 N-m (1,860 in.lbs.) Impact Driver

TD003G

40V max



Capacity	Machine screw: M4 - M8 (5/32 - 5/16") Coarse thread (in length): 22 - 125 mm (7/8 - 4-7/8")
Max fastening torque	210 N-m (1,860 in.lbs.)
Fastening torque	Hard / Med. / Soft: 170 / 50 / 20 N-m (1,510 / 440 / 180 in.lbs.)
No load speed	Max / Hard / Med. / Soft: 0 - 3,700 / 0 - 3,200 / 0 - 2,100 / 0 - 1,100 min ⁻¹
Impacts per minute	Max / Hard / Med. / Soft: 0 - 4,100 / 0 - 3,600 / 0 - 2,600 / 0 - 1,400 min ⁻¹
Dimensions (L x W x H)	121 x 86 x 245 mm (4-3/4 x 3-3/8 x 9-5/8")
Net weight	1.7 - 2.9 kg (3.7 - 6.4 lbs.)



18V LXT BL Cordless 210 N-m (1,860 in.lbs.) Impact Driver, 4-Speed + T-Mode

DTD201

18V

new



Capacity	Machine screw: M4 - M8 (5/32 - 5/16") Coarse thread (in length): 22 - 125 mm (7/8 - 4-7/8")
Max fastening torque	210 N-m (1,860 ft.lbs.)
No load speed	Max / Hard / Med. / Soft: 0 - 3,700 / 0 - 3,200 / 0 - 2,100 / 0 - 1,100 min ⁻¹
Impacts per minute	Max / Hard / Med. / Soft: 0 - 4,400 / 0 - 4,200 / 0 - 3,600 / 0 - 2,000 min ⁻¹
Dimensions (L x W x H)	121 x 81 x 246 mm (4-3/4 x 3-3/16 x 9-11/16")
Net weight	1.3 - 2.3 kg (2.9 - 5.1 lbs.)



18V LXT BL Cordless Wood/Bolt/T-Mode 180 N-m (1,590 in.lbs.) Impact Driver

DTD173

18V



Capacity	Machine screw: M4 - M8 (5/32 - 5/16") Coarse thread (in length): 22 - 125 mm (7/8 - 4-7/8")
Max fastening torque	180 N-m (1,590 in.lbs.)
Fastening torque	Hard / Med. / Soft: 170 / 50 / 20 N-m (1,510 / 440 / 180 in.lbs.)
No load speed	Max / Hard / Med. / Soft: 0 - 3,600 / 0 - 3,200 / 0 - 2,100 / 0 - 1,100 min ⁻¹
Impacts per minute	Max / Hard / Med. / Soft: 0 - 3,800 / 0 - 3,200 / 0 - 2,600 / 0 - 1,100 min ⁻¹
Dimensions (L x W x H)	111 x 81 x 234 mm (4-3/8 x 3-3/16 x 9-1/4")
Net weight	1.5 kg (3.3 lbs.)



18V LXT BL Brushless Cordless 170 N-m (1,500 in.lbs.) Impact Driver

DTD153

18V



Capacity	Machine screw: M4 - M8 (5/32 - 5/16") Coarse thread (in length): 22 - 125 mm (7/8 - 4-7/8")
Max fastening torque	170 N-m (1,500 in.lbs.)
No load speed	0 - 3,400 min ⁻¹
Impacts per minute	0 - 3,600 min ⁻¹
Dimensions (L x W x H)	126 x 79 x 238 mm (5 x 3-1/8 x 9-3/8")
Net weight	1.3 - 1.6 kg (2.9 - 3.5 lbs.)



18V LXT Li-Ion Cordless 165 N-m (1,460 in.lbs.) Impact Driver

DTD152

18V



Capacity	Machine screw: M4 - M8 (5/32 - 5/16") Coarse thread (in length): 22 - 125 mm (7/8 - 4-7/8")
Max fastening torque	165 N-m (1,460 in.lbs.)
No load speed	0 - 2,900 min ⁻¹
Impacts per minute	0 - 3,500 min ⁻¹
Dimensions (L x W x H)	137 x 79 x 238 mm (5-3/8 x 3-1/8 x 9-3/8")
Net weight	1.3 - 1.6 kg (2.8 - 3.5 lbs.)



18V LXT Li-Ion Cordless 155 N-m (1,370 in.lbs.) Impact Driver

DTD156

18V



Capacity	Machine screw: M4 - M8 (5/32 - 5/16") Coarse thread (in length): 22 - 125 mm (7/8 - 4-7/8")
Max fastening torque	155 N-m (1,370 in.lbs.)
No load speed	0 - 2,500 min ⁻¹
Impacts per minute	0 - 3,000 min ⁻¹
Dimensions (L x W x H)	w/ BL1830B / BL1840B / BL1850B / BL1860B: 143 x 79 x 241 mm (5-5/8 x 3-1/8 x 9-1/2")
Net weight	1.3 - 1.6 kg (2.9 - 3.6 lbs.)



18V LXT BL Brushless Cordless A-Mode (Assist Mode) 140 N-m (1,240 in.lbs.) Impact Driver

DTD157

18V



Capacity	Machine screw: M4 - M8 mm (5/32 - 5/16") Coarse thread (in length): 22 - 90 mm (7/8 - 3-1/2")
Max fastening torque	140 N-m (1,240 in.lbs.)
No load speed	Hard / Soft: 0 - 3,000 / 0 - 1,300 min ⁻¹
Impacts per minute	Hard / Soft: 0 - 4,100 / 0 - 2,000 min ⁻¹
Dimensions (L x W x H)	w/ BL1830B / BL1840B / BL1850B / BL1860B: 133 x 81 x 232 mm (5-1/4 x 3-3/16 x 9-1/8")
Net weight	1.2 - 1.5 kg (2.6 - 3.3 lbs.)



Screwing/Drilling

12V max CXT BL Brushless Cordless A-Mode (Assist Mode) 135 N-m (1,200 in.lbs.) Impact Driver

TD111D

12V max



Capacity	Machine screw: M4 - M8 mm (5/32 - 5/16") Coarse thread (in length): 22 - 90 mm (7/8 - 3-1/2")
Max fastening torque	135 N-m (1,200 in.lbs.)
No load speed	Hard / Soft: 0 - 3,000 / 0 - 1,300 min ⁻¹
Impacts per minute	Hard / Soft: 0 - 3,900 / 0 - 1,600 min ⁻¹
Dimensions (L x W x H)	135 x 66 x 210 mm (5-5/16 x 2-5/8 x 8-1/4")
Net weight	0.97 - 1.1 kg (2.1 - 2.5 lbs.)

CXT BL XPT



12V max CXT Li-Ion Cordless 110 N-m (970 in.lbs.) Impact Driver

TD110D

12V max



Capacity	Machine screw: M4 - M8 mm (5/32 - 5/16") Coarse thread (in length): 22 - 90 mm (7/8 - 3-1/2")
Max fastening torque	110 N-m (970 in.lbs.)
No load speed	0 - 2,600 min ⁻¹
Impacts per minute	0 - 3,500 min ⁻¹
Dimensions (L x W x H)	153 x 66 x 204 mm (6 x 2-5/8 x 8-1/8")
Net weight	1 - 1.2 kg (2.3 - 2.6 lbs.)

CXT



10.8V (12V max) Li-Ion Cordless 90 N-m (800 in.lbs.) Impact Driver

TD090D

10.8V



Capacity	Machine screw: M4 - M8 mm (5/32 - 5/16") Coarse thread (in length): 22 - 90 mm (7/8 - 3-1/2")
Max fastening torque	90 N-m (800 in.lbs.)
No load speed	0 - 2,400 min ⁻¹
Impacts per minute	0 - 3,000 min ⁻¹
Dimensions (L x W x H)	155 x 54 x 178 mm (6-1/8 x 2-1/8 x 7")
Net weight	0.92 kg (2 lbs.)



7.2V Li-Ion Cordless Two-Position 25 N-m (220 in.lbs.) Impact Driver

TD022D

7.2V



Capacity	Machine screw: M3 - M8 (1/8 - 5/16") Coarse thread (in length): 22 - 45 mm (7/8 - 1-3/4")
Max fastening torque	25 N-m (220 in.lbs.)
No load speed	0 - 2,450 min ⁻¹
Impacts per minute	0 - 3,000 min ⁻¹
Dimensions (L x W x H)	Straight style: 282 x 42 x 52 mm (11-1/8 x 1-5/8 x 2-1/16") Pistol Style: 227 x 42 x 142 mm (8-15/16 x 1-5/8 x 5-5/8")
Net weight	0.56 kg (1.2 lbs.)



18V Li-Ion Cordless 140 N-m (1,240 in.lbs.) Impact Driver, G-Battery

TD127D

18V



Capacity	Machine screw: M4 - M8 (5/32 - 5/16") Coarse thread (in length): 22 - 125 mm (7/8 - 4-7/8")
Max fastening torque	140 N-m (1,240 in.lbs.)
No load speed	0 - 2,300 min ⁻¹
Impacts per minute	0 - 3,000 min ⁻¹
Dimensions (L x W x H)	173 x 82 x 225 mm (6-13/16 x 3-1/4 x 8-7/8")
Net weight	1.5 kg (3.2 lbs.)



120 N·m (88.5 ft.lbs.) Impact Driver

6952



Continuous rating	270W
Input	
Capacity	Machine screw: M4 - M10 (5/32 - 3/8") Standard bolt: M6 - M14 (7/32 - 9/16") High strength bolt: M6 - M10 (7/32 - 3/8")
Driving shank (Hex)	6.35 mm (1/4")
Max fastening torque	120 N-m (88.5 ft.lbs.)
No load speed	0 - 3,200 min ⁻¹
Impacts per minute	0 - 3,100 min ⁻¹
Overall length	229 mm (9")
Net weight	1.4 kg (3.1 lbs.)



100 N·m (74 ft.lbs.) Impact Driver

TD0100



Continuous rating	230W
Input	
Capacity	Machine screw: M4 - M8 (5/32 - 5/16") Standard bolt: M5 - M14 (3/16 - 9/16") High strength bolt: M5 - M10 (3/16 - 3/8")
Driving shank (Hex)	6.35 mm (1/4")
Max fastening torque	100 N-m (74 ft.lbs.)
No load speed	0 - 3,600 min ⁻¹
Impacts per minute	0 - 3,200 min ⁻¹
Dimensions (L x W x H)	218 x 60 x 180 mm (8-5/8 x 2-3/8 x 7-1/8")
Net weight	0.96 kg (2.1 lbs.)



100 N·m (74 ft.lbs.) Impact Driver with LED Light

TD0101F



Continuous rating	230W
Input	
Capacity	Machine screw: M4 - M8 (5/32 - 5/16") Standard bolt: M5 - M14 (3/16 - 9/16") High strength bolt: M5 - M10 (3/16 - 3/8") Coarse thread (in length): 22 - 90 mm (7/8 - 3-1/2")
Driving shank (Hex)	6.35 mm (1/4")
Max fastening torque	100 N-m (74 ft.lbs.)
No load speed	0 - 3,600 min ⁻¹
Impacts per minute	0 - 3,200 min ⁻¹
Dimensions (L x W x H)	184 x 67 x 192 mm (7-1/4 x 2-5/8 x 7-9/16")
Net weight	0.99 kg (2.2 lbs.)



100 N·m (74 ft.lbs.) Impact Driver

TD0101



Continuous rating	230W
Input	
Capacity	Machine screw: M4 - M8 (5/32 - 5/16") Standard bolt: M5 - M14 (3/16 - 9/16") High strength bolt: M5 - M10 (3/16 - 3/8")
Driving shank (Hex)	6.35 mm (1/4")
Max fastening torque	100 N-m (74 ft.lbs.)
No load speed	0 - 3,600 min ⁻¹
Impacts per minute	0 - 3,200 min ⁻¹
Dimensions (L x W x H)	184 x 67 x 192 mm (7-1/4 x 2-5/8 x 7-9/16")
Net weight	0.99 kg (2.2 lbs.)



18V LXT Li-Ion Cordless 60 N-m (530 in.lbs.) Angle Impact Driver

DTL061

18V



Capacity	Machine screw: M4 - M8 (5/32 - 5/16") Standard bolt: M4 - M12 (5/32 - 1/2") High strength bolt: M4 - M8 (5/32 - 5/16")
Hex shank	6.35 mm (1/4")
Max fastening torque	60 N-m (530 in.lbs.)
No load speed	0 - 2,000 min ⁻¹
Impacts per minute	0 - 3,000 min ⁻¹
Dimensions (L x W x H)	387 x 78 x 116 mm (15-1/4 x 3-1/16 x 4-9/16")
Net weight	1.4 - 2 kg (3.1 - 4.3 lbs.)



12V max CXT Li-Ion Cordless 60 N-m (530 in.lbs.) Angle Impact Driver

TL064D

12V max



Capacity	Machine screw: M4 - M8 (5/32 - 5/16") Standard bolt: M4 - M12 (5/32 - 1/2") High strength bolt: M4 - M8 (5/32 - 5/16")
Hex shank	6.35 mm (1/4")
Max fastening torque	60 N-m (530 in.lbs.)
No load speed	0 - 2,000 min ⁻¹
Impacts per minute	0 - 3,000 min ⁻¹
Dimensions (L x W x H)	361 x 66 x 86 mm (14-1/4 x 2-5/8 x 3-3/8")
Net weight	1.2 - 1.6 kg (2.7 - 3.6 lbs.)



18V LXT BL Brushless Cordless 4 Mode 150 N-m (1,330 in.lbs.) Impact Driver

DTP141

18V



Capacity	Steel: 10 mm (3/8") Wood: 21 mm (13/16") Masonry: 8 mm (5/16")
Max fastening torque	Impact-driver mode: 150 N-m (1,330 in.lbs.) Drill mode (Hard / Soft): 22 / 13 N-m
No load speed	Impact-driver mode (Hard / Med. / Soft): 0 - 2,700 / 0 - 2,200 / 0 - 1,300 min ⁻¹ Drill mode (Hi / Lo): 0 - 2,700 / 0 - 700 min ⁻¹
Impacts per minute	0 - 3,200 / 0 - 2,400 / 0 - 1,200 min ⁻¹
Dimensions (L x W x H)	171 x 79 x 250 mm (6-3/4 x 3-1/8 x 9-7/8")
Net weight	1.5 - 1.9 kg (3.4 - 4.1 lbs.)



18V LXT BL Brushless Cordless Oil-Pulse Driver

DTS141

18V



Capacity	Machine screw: M4 - M8 (5/32 - 5/16") Standard bolt: M5 - M8 (3/16 - 5/16") High strength bolt: M5 - M6 (3/16 - 1/4") Coarse thread (in length): 22 - 125 mm (7/8 - 4-7/8")
Max fastening torque	40 N-m (355 in.lbs.)
No load speed	Hard: 0 - 3,200 min ⁻¹ Med.: 0 - 2,000 min ⁻¹ Soft: 0 - 1,200 min ⁻¹
Impacts per minute	Hard: 0 - 2,700 min ⁻¹ Med.: 0 - 2,200 min ⁻¹ Soft: 0 - 1,400 min ⁻¹
Dimensions (L x W x H)	136 x 79 x 240 mm (5-3/8 x 3-1/8 x 9-1/2")
Net weight	1.3 - 1.6 kg (2.8 - 3.5 lbs.)



13 mm (1/2") 720 W Variable 2-Speed Reversing Drill with Keyless Chuck

DP4011



Continuous rating	720W
Input	
Capacity	Steel, Hi: 8 mm (5/16") Steel, Lo: 13 mm (1/2") Wood, Hi: 25 mm (1") Wood, Lo: 40 mm (1-9/16") Wood (Self-feed bit): 90 mm (90")
No load speed	High: 0 - 2,900 min ⁻¹ Low: 0 - 1,200 min ⁻¹
Chuck capacity	1.5 - 13.0 mm (1/16 - 1/2")
Dimensions (L x W x H)	347 x 70 x 220 mm (13-5/8 x 2-3/4 x 8-5/8")
Net weight	2.3 kg (5 lbs.)



13 mm (1/2") 720 W Variable 2-Speed Reversing Drill with Keyed Chuck

DP4010



Continuous rating	720W
Input	
Capacity	Steel, Hi: 8 mm (5/16") Steel, Lo: 13 mm (1/2") Wood, Hi: 25 mm (1") Wood, Lo: 40 mm (1-9/16") Wood (Self-feed bit): 90 mm (3-1/2")
No load speed	High: 0 - 2,900 min ⁻¹ Low: 0 - 1,200 min ⁻¹
Chuck capacity	1.5 - 13.0 mm (1/16 - 1/2")
Dimensions (L x W x H)	347 x 70 x 220 mm (13-5/8 x 2-3/4 x 8-5/8")
Net weight	2.3 kg (5 lbs.)



16 mm (5/8") 750 W Reversing D-Handle Drill with Keyed Chuck

DS5000



Continuous rating	750W
Input	
Capacity	Steel: 16 mm (5/8") Wood: 36 mm (1-7/16") Wood (Self-feed bit): 127 mm (5")
No load speed	600 min ⁻¹
Chuck capacity	3 - 16 mm (1/8 - 5/8")
Dimensions (L x W x H)	348 x 83 x 401 mm (13-3/4 x 3-1/4 x 15-3/4")
Net weight	3 kg (6.6 lbs.)



13 mm (1/2") 850 W Drill with Keyed Chuck

6305



Continuous rating	850W
Input	
Capacity	Steel: 13 mm (1/2") Wood: 30 mm (1-3/16") Wood (Self-feed bit): 60 mm (2-3/8")
No load speed	1,450 min ⁻¹
Dimensions (L x W x H)	346 x 84 x 152 mm (13-5/8 x 3-5/16 x 6")
Net weight	2.8 kg (6.2 lbs.)



13 mm (1/2") 750 W Variable Speed Reversing D-Handle Drill with Keyed Chuck

DS4012



Continuous rating	750W
Input	
Capacity	Steel: 13 mm (1/2") Wood: 36 mm (1-7/16") Wood (Self-feed bit): 127 mm (5")
No load speed	0 - 600 min ⁻¹
Chuck capacity	2 - 13 mm (1/16 - 1/2")
Dimensions (L x W x H)	340 x 83 x 390 mm (13-3/8 x 3-1/4 x 15-3/8")
Net weight	2.8 kg (6.2 lbs.)



13 mm (1/2") 750 W Reversing D-Handle Drill with Keyed Chuck

DS4011



Continuous rating	750W
Input	
Capacity	Steel: 13 mm (1/2") Wood: 36 mm (1-7/16") Wood (Self-feed bit): 127 mm (5")
No load speed	600 min ⁻¹
Chuck capacity	2 - 13 mm (1/16 - 1/2")
Dimensions (L x W x H)	340 x 83 x 401 mm (13-3/8 x 3-1/4 x 15-3/4")
Net weight	2.8 kg (6.3 lbs.)



Screwing/Drilling

13 mm (1/2") 750 W Variable Speed Reversing Drill with Keyless Chuck

DP4003



Continuous rating	750W
Input	
Capacity	Steel: 13 mm (1/2") Wood: 38 mm (1-1/2") Wood (Self-feed bit): 76 mm (3")
No load speed	0 - 700 min ⁻¹
Chuck capacity	1.5 - 13 mm (1/16 - 1/2")
Overall length	308 mm (12-1/8")
Net weight	2.5 kg (5.4 lbs.)



13 mm (1/2") 750 W Variable Speed Reversing Drill with Keyed Chuck

DP4002



Continuous rating	750W
Input	
Capacity	Steel: 13 mm (1/2") Wood: 38 mm (1-1/2") Wood (Self-feed bit): 76 mm (3")
No load speed	0 - 700 min ⁻¹
Chuck capacity	2 - 13 mm (1/16 - 1/2")
Overall length	304 mm (12")
Net weight	2.7 kg (5.8 lbs.)



13 mm (1/2") 750 W Variable Speed Reversing Drill with Keyed Chuck

DP4000



Continuous rating	750W
Input	
Capacity	Steel: 13 mm (1/2") Wood: 38 mm (1-1/2") Wood (Self-feed bit): 76 mm (3")
No load speed	0 - 950 min ⁻¹
Chuck capacity	2 - 13 mm (1/16 - 1/2")
Overall length	304 mm (12")
Net weight	2.5 kg (5.6 lbs.)



13 mm (1/2") 630 W Variable Speed Reversing Drill with Keyless Chuck

DP4021



Continuous rating	630W
Input	
Capacity	Steel: 13 mm (1/2") Wood: 30 mm (1-3/16")
No load speed	0 - 3,000 min ⁻¹
Chuck capacity	1.5 - 13 mm (1/16 - 1/2")
Dimensions (L x W x H)	271 x 66 x 209 mm (10-5/8 x 2-5/8 x 8-1/4")
Net weight	1.6 kg (3.5 lbs.)



13 mm (1/2") 630 W Variable Speed Reversing Drill with Keyed Chuck

DP4020



Continuous rating	630W
Input	
Capacity	Steel: 13 mm (1/2") Wood: 30 mm (1-3/16")
No load speed	0 - 3,000 min ⁻¹
Chuck capacity	1.5 - 13 mm (1/16 - 1/2")
Dimensions (L x W x H)	269 x 66 x 209 mm (10-5/8 x 2-5/8 x 8-1/4")
Net weight	1.7 kg (3.7 lbs.)



10 mm (3/8") 450 W Variable Speed Reversing Drill with Keyless Chuck

6413



Continuous rating	450W
Input	
Capacity	Steel: 10 mm (3/8") Wood: 25 mm (1") Wood (Self-feed bit): 50 mm (2")
No load speed	0 - 3,400 min ⁻¹
Chuck capacity	1.5 - 10 mm (1/16 - 3/8")
Dimensions (L x W x H)	234 x 64 x 183 mm (9-1/4 x 2-1/2 x 7-1/4")
Net weight	1.3 kg (2.9 lbs.)



10 mm (3/8") 450 W Variable Speed Reversing Drill with Keyed Chuck

6412



Continuous rating	450W
Input	
Capacity	Steel: 10 mm (3/8") Wood: 25 mm (1") Wood (Self-feed bit): 50 mm (2")
No load speed	0 - 3,400 min ⁻¹
Chuck capacity	1.5 - 10 mm (1/16 - 3/8")
Dimensions (L x W x H)	228 x 64 x 183 mm (9 x 2-1/2 x 7-1/4")
Net weight	1.3 kg (2.9 lbs.)



6.5 mm (1/4") 370 W High Speed Variable Speed Reversing Drill with Keyless Chuck

DP2011



Continuous rating	370W
Input	
Capacity	Steel: 6.5 mm (1/4") Wood: 15 mm (9/16") Wood (Self-feed bit): 30 mm (1-3/16")
No load speed	0 - 4,200 min ⁻¹
Chuck capacity	0.8 - 6.5mm (1/32 - 1/4")
Dimensions (L x W x H)	222 x 64 x 175 mm (8-3/4 x 2-1/2 x 6-7/8")
Net weight	1.1 kg (2.4 lbs.)



6.5 mm (1/4") 370 W High Speed Variable Speed Reversing Drill with Keyed Chuck

DP2010



Continuous rating	370W
Input	
Capacity	Steel: 6.5 mm (1/4") Wood: 15 mm (9/16") Wood (Self-feed bit): 30 mm (1-3/16")
No load speed	0 - 4,200 min ⁻¹
Chuck capacity	0.5 - 6.5mm (1/64 - 1/4")
Dimensions (L x W x H)	209 x 64 x 175 mm (8-1/4 x 2-1/2 x 6-7/8")
Net weight	1 kg (2.2 lbs.)



6.5 mm (1/4") 500 W High Speed D-Handle Drill with Keyed Chuck

DD2020



Continuous rating	500W
Input	
Capacity	Wood: 12 mm (15/32") Wood (Self-feed bit): 24 mm (15/16")
No load speed	10,000 min ⁻¹
Chuck capacity	0.5 - 6.5mm (1/64 - 1/4")
Dimensions (L x W x H)	274 x 67 x 131 mm (10-3/4 x 2-5/8 x 5-1/8")
Net weight	1.3 kg (2.9 lbs.)



40Vmax XGT BL ADT Cordless 13 mm (1/2") Angle Drill with Keyed Chuck

DA001G

40V max



Capacity	Steel: 13 mm (1/2") Wood (Self-feed bit), Hi: 65 mm (2-9/16") Wood (Self-feed bit), Lo: 118 mm (4-5/8") Wood (Hole saw), Hi: 105 mm (4-1/8") Wood (Hole saw), Lo: 159 mm (6-1/4")
Chuck capacity	2 - 13 mm (1/16 - 1/2")
No load speed	High: 0 - 1,500 min ⁻¹ Low: 0 - 400 min ⁻¹
Max torque	High: 55 N-m (487 in.lbs) Low: 136 N-m (1,210 in.lbs)
Dimensions (L x W x H)	545 x 128 x 199 mm (21-1/2 x 5 x 7-7/8")
Net weight	5.3 - 6.2 kg (11.7 - 13.7 lbs.)



40Vmax XGT BL ADT Cordless 13 mm (1/2") Angle Drill

DA002G

40V max



Capacity	Steel: 13 mm (1/2") Wood (Self-feed bit), Hi: 65 mm (2-9/16") Wood (Self-feed bit), Lo: 118 mm (4-5/8") Wood (Hole saw), Hi: 105 mm (4-1/8") Wood (Hole saw), Lo: 159 mm (6-1/4")
Hex shank	11 mm (7/16")
No load speed	High: 0 - 1,500 min ⁻¹ Low: 0 - 400 min ⁻¹
Max torque	High: 55 N-m (487 in.lbs) Low: 136 N-m (1,210 in.lbs)
Dimensions (L x W x H)	w/ BL4050F: 566 x 128 x 193 mm (22-1/4 x 5 x 7-5/8")
Net weight	4.9 - 5.8 kg (10.8 - 12.8 lbs.)



18V X2 (36V) LXT BL ADT Cordless 13 mm (1/2") Angle Drill with Keyed Chuck

DDA460

18V x2



Capacity	Steel: 13 mm (1/2") Wood (Self-feed bit), Hi: 65 mm (2-9/16") Wood (Self-feed bit), Lo: 118 mm (4-5/8") Wood (Hole saw), Hi: 105 mm (4-1/8") Wood (Hole saw), Lo: 159 mm (6-1/4") Hole saw: 118 mm (4-5/8")
Chuck capacity	2 - 13 mm (5/64 - 1/2")
No load speed	High: 0 - 1,400 min ⁻¹ Low: 0 - 350 min ⁻¹
Max fastening torque	High: 48 N-m (430 in.lbs.) Low: 136 N-m (1,210 in.lbs.)
Dimensions (L x W x H)	538 x 128 x 223 mm (21-1/4 x 5 x 8-3/4")
Net weight	5.7 - 6.4 kg (12.6 - 14.0 lbs.)



18V LXT BL Cordless Angle Drill with Keyed Chuck

DDA450

18V



Capacity	Steel: 13 mm (1/2") Wood (Self-feed bit), Hi: 50 mm (2") Wood (Self-feed bit), Lo: 65 mm (2-9/16") Wood (Hole saw), Hi: 101 mm (4") Wood (Hole saw), Lo: 127 mm (5")
Chuck capacity	2 - 13 mm (1/16 - 1/2")
No load speed	High: 0 - 1,400 min ⁻¹ Low: 0 - 450 min ⁻¹
Max fastening torque	High: 26 N-m (230 in.lbs.) Low: 70 N-m (620 in.lbs.)
Dimensions (L x W x H)	w/ BL1830B / BL1840B / BL1850B / BL1860B: 434 x 82 x 179 mm (17-1/8 x 3-1/4 x 7")
Net weight	3.2 - 3.5 kg (7.1 - 7.7 lbs.)



18V LXT BL Cordless Angle Drill

DDA451

18V



Capacity	Steel: 13 mm (1/2") Wood (Self-feed bit), Hi: 50 mm (2") Wood (Self-feed bit), Lo: 65 mm (2-9/16") Wood (Hole saw), Hi: 101 mm (4") Wood (Hole saw), Lo: 127 mm (5")
Hex shank	11 mm (7/16")
No load speed	High: 0 - 1,400 min ⁻¹ Low: 0 - 450 min ⁻¹
Max fastening torque	High: 26 N-m (230 in.lbs.) Low: 70 N-m (620 in.lbs.)
Dimensions (L x W x H)	w/ BL1830B / BL1840B / BL1850B / BL1860B: 434 x 82 x 163 mm (17-1/8 x 3-1/4 x 6-3/8")
Net weight	2.8 - 3.3 kg (6.2 - 7.3 lbs.)



18V LXT Li-Ion Cordless 10 mm (3/8") Angle Drill, Keyless Chuck

DDA351

18V



Capacity	Steel: 10 mm (3/8") Wood: 25 mm (1") Hole saw: 50 mm (2")
Chuck capacity	1.5 - 10 mm (1/32 - 3/8")
No load speed	0 - 1,800 min ⁻¹
Dimensions (L x W x H)	326 x 79 x 115 mm (12-7/8 x 3-1/8 x 4-1/2")
Net weight	1.6 - 1.9 kg (4.2 - 3.5 lbs.)



18V LXT Li-Ion Cordless 10 mm (3/8") Angle Drill, Keyed Chuck

DDA350

18V



Capacity	Steel: 10 mm (3/8") Wood: 25 mm (1") Hole saw: 50 mm (2")
Chuck capacity	1.5 - 10 mm (1/16 - 3/8")
No load speed	0 - 1,800 min ⁻¹
Dimensions (L x W x H)	314 x 79 x 115 mm (12-3/8 x 3-1/8 x 4-1/2")
Net weight	1.5 - 1.8 kg (4.1 - 3.4 lbs.)



12V max CXT Li-Ion Cordless 10 mm (3/8") Angle Drill, Keyless Chuck

DA333D

12V max



Capacity	Steel: 10 mm (3/8") Wood: 12 mm (1/2") Hole saw: 24 mm (15/16")
Chuck capacity	0.8 - 10 mm (1/32 - 3/8")
No load speed	0 - 1,100 min ⁻¹
Dimensions (L x W x H)	w/ BL1041B: 332 x 68 x 95 mm (13-1/8 x 2-11/16 x 3-3/4")
Net weight	1.2 - 1.4 kg (2.7 - 3 lbs.)



12V max CXT Li-Ion Cordless 10 mm (3/8") Angle Drill, Keyed Chuck

DA332D

12V max



Capacity	Steel: 10 mm (3/8") Wood: 12 mm (1/2") Hole saw: 24 mm (15/16")
Chuck capacity	1.5 - 10 mm (1/16 - 3/8")
No load speed	0 - 1,100 min ⁻¹
Dimensions (L x W x H)	313 x 68 x 86 mm (12-3/8 x 2-11/16 x 3-3/8")
Net weight	1.2 - 1.3 kg (2.6 - 2.9 lbs.)



13 mm (1/2") 1,050 W Angle Drill with Keyed Chuck

DA4031



Continuous rating	1,050W
Input	
Capacity	Steel: 13 mm (1/2") Wood (Self-feed bit), Hi: 65 mm (2-9/16") Wood (Self-feed bit), Lo: 118 mm (4-5/8")
Chuck capacity	2 - 13 mm (1/16 - 1/2")
No load speed	High: 1,200 min ⁻¹ Low: 300 min ⁻¹
Overall length	462 mm (18-3/16")
Net weight	6.3 kg (13.9 lbs.)



Screwing/Drilling

13 mm (1/2") 710 W Angle Drill with Keyed Chuck

DA4000LR



Continuous rating	710W
Input	
Capacity	Steel: 13 mm (1/2") Wood (Self-feed bit), Hi: 65 mm (2-9/16") Wood (Self-feed bit), Lo: 118 mm (4-5/8")
Chuck capacity	2 - 13 mm (1/16 - 1/2")
No load speed	High: 0 - 900 min ⁻¹ Low: 0 - 400 min ⁻¹
Overall length	413 mm (16-1/4")
Net weight	4 kg (8.9 lbs.)



10 mm (3/8") 450 W Angle Drill with Keyless Chuck, LED job light

DA3011F



Continuous rating	450W
Input	
Capacity	Steel: 10 mm (3/8") Wood: 25 mm (1")
Chuck capacity	1.5 - 10 mm (1/16 - 3/8")
No load speed	0 - 2,400 min ⁻¹
Overall length	282 mm (11-1/8")
Net weight	1.6 kg (3.5 lbs.)



10 mm (3/8") 450 W Angle Drill with Keyed Chuck, LED job light

DA3010F



Continuous rating	450W
Input	
Capacity	Steel: 10 mm (3/8") Wood: 25 mm (1")
Chuck capacity	1.5 - 10 mm (1/16 - 3/8")
No load speed	0 - 2,400 min ⁻¹
Dimensions (L x W x H)	270 x 10-5/8 x 61 mm (2-3/8 x 79 x 3-1/8")
Net weight	1.4 kg (3.1 lbs.)



10 mm (3/8") 450 W Angle Drill with Keyed Chuck

DA3010



Continuous rating	450W
Input	
Capacity	Steel: 10 mm (3/8") Wood: 25 mm (1")
Chuck capacity	1.5 - 10 mm (1/16 - 3/8")
No load speed	0 - 2,400 min ⁻¹
Overall length	270 mm (10-5/8")
Net weight	1.6 kg (3.5 lbs.)



50 mm (2") Magnetic Drill

HB500



Continuous rating	1,150W
Input	
Capacity	Steel: 50 mm (2")
Chuck capacity	16 mm (5/8")
No load speed	350 / 650 min ⁻¹
Magnetic clamping force	9,300 N (950 kg)
Dimensions (L x W x H)	290 x 218 x 450 mm (11-3/8 x 8-5/8 x 17-3/4")
Net weight	18.5 kg (40.8 lbs.)

35 mm (1-3/8") Magnetic Drill

HB350



Continuous rating	1,050W
Input	
Capacity	Steel: 35 mm (1-3/8")
Chuck capacity	13 mm (1/2")
No load speed	850 min ⁻¹
Magnetic clamping force	8,000 N (816 kg)
Dimensions (L x W x H)	225 x 195 x 365 mm (8-7/8 x 7-5/8 x 14-3/8")
Net weight	11.6 kg (25.6 lbs.)



Cordless Impact Wrench



High

Low

XGT

LXT

40V max **BL MOTOR** **3,150 N·m**
TW010G Long anvil
XGT XPT
 Square drive size **1" (25.4mm)**
 M27 - 45 (Standard Bolt Size)
 M20 - 33 (High strength Bolt Size)

40V max **BL MOTOR** **1,800 N·m**
TW001G
XGT XPT
 Square drive size **3/4" (19mm)**
 M12 - 36 (Standard Bolt Size)
 M10 - 27 (High strength Bolt Size)

40V max **BL MOTOR** **1,700 N·m**
TW002G C ring
XGT XPT
 Square drive size **1/2" (12.7mm)**
 M12 - 36 (Standard Bolt Size)
 M10 - 27 (High strength Bolt Size)

40V max **BL MOTOR** **1,500 N·m**
TW011G Long anvil
XGT XPT
 Square drive size **3/4" (19mm)**
 M12 - 36 (Standard Bolt Size)
 M10 - 27 (High strength Bolt Size)

40V max **BL MOTOR** **1,360 N·m**
TW003G Pin detent
XGT XPT
 Square drive size **1/2" (12.7mm)**
 M12 - 36 (Standard Bolt Size)
 M10 - 27 (High strength Bolt Size)

40V max **BL MOTOR** **760 N·m**
TW007G TW008G C ring Pin detent
XGT XPT
 Square drive size **1/2" (12.7mm)**
 M10 - 24 (Standard Bolt Size)
 M10 - 16 (High strength Bolt Size)

40V max **BL MOTOR** **350 N·m**
TW004G TW005G C ring Pin detent
XGT XPT
 Square drive size **1/2" (12.7mm)**
 M10 - 20 (Standard Bolt Size)
 M10 - 16 (High strength Bolt Size)

18V **BL MOTOR** **1,200 N·m**
DTW1002
LXT XPT
 Square drive size **1/2" (12.7mm)**
 M12 - 30 (Standard Bolt Size)
 M10 - 24 (High strength Bolt Size)

18V **BL MOTOR** **1,250 N·m**
DTW1001
LXT XPT
 Square drive size **3/4" (19mm)**
 M12 - 30 (Standard Bolt Size)
 M10 - 24 (High strength Bolt Size)

18V **BL MOTOR** **1,050 N·m**
DTW1004
LXT XPT
 Square drive size **1/2" (12.7mm)**
 M12 - 30 (Standard Bolt Size)
 M10 - 20 (High strength Bolt Size)

18V **BL MOTOR** **700 N·m**
DTW700 DTW701 C ring Pin detent
LXT XPT
 Square drive size **1/2" (12.7mm)**
 M10 - 24 (Standard Bolt Size)
 M10 - 16 (High strength Bolt Size)

18V **440 N·m**
DTW450 **LXT** Brushed Motor
 Square drive size **1/2" (12.7mm)**
 M12 - 22 (Standard Bolt Size)
 M12 - 16 (High strength Bolt Size)

18V **BL MOTOR** **330 N·m**
DTW300 DTW301 C ring Pin detent
LXT XPT
 Square drive size **1/2" (12.7mm)**
 M10 - 20 (Standard Bolt Size)
 M10 - 16 (High strength Bolt Size)

18V **230 N·m**
DTW251 **LXT** Brushed Motor
 Square drive size **1/2" (12.7mm)**
 M10 - 16 (Standard Bolt Size)
 M10 - 14 (High strength Bolt Size)

18V **BL MOTOR** **210 N·m**
DTW181 **LXT XPT**
 Square drive size **1/2" (12.7mm)**
 M8 - 16 (Standard Bolt Size)
 M6 - 12 (High strength Bolt Size)

18V **190 N·m**
DTW190 **LXT** Brushed Motor
 Square drive size **1/2" (12.7mm)**
 M8 - 16 (Standard Bolt Size)
 M8 - 12 (High strength Bolt Size)

18V **BL MOTOR** **1,360 N·m**
DTW1005 Long anvil
LXT XPT
 Square drive size **3/4" (19mm)**
 M12 - 30 (Standard Bolt Size)
 M10 - 24 (High strength Bolt Size)

18V **BL MOTOR** **800 N·m**
DTW800 **LXT**
 Hex shank size **7/16" (11.1mm)**
 M12 - 24 (Standard Bolt Size)
 M10 - 22 (High strength Bolt Size)

18V **BL MOTOR** **300 N·m**
DTW302 **LXT XPT**
 Square drive size **3/8" (9.5mm)**
 M10 - 20 (Standard Bolt Size)
 M10 - 16 (High strength Bolt Size)

18V **210 N·m**
DTW253 **LXT** Brushed Motor
 Square drive size **3/8" (9.5mm)**
 M8 - 16 (Standard Bolt Size)
 M6 - 12 (High strength Bolt Size)

18V **BL MOTOR** **180 N·m**
DTW180 **LXT XPT**
 Square drive size **3/8" (9.5mm)**
 M8 - 16 (Standard Bolt Size)
 M6 - 12 (High strength Bolt Size)

Max Fastening Torque (N·m)

Screwing/Drilling

40Vmax XGT BL Cordless 1" (25.4 mm) 3,150 N-m (2,320 ft.lbs.) Impact Wrench, Forward/Reverse Rotation Auto Stop Mode

TW010G

40V max



Square drive	25.4 mm (1")
Max fastening torque	3,150 N-m (2,323 ft.lbs.)
Fastening capacities	Standard bolt: M27 - M45 (1-1/8 - 1-7/8") High strength bolt: M20 - M33 (3/4 - 1-3/8")
Nut-busting torque	4,000 N-m (2,950 ft.lbs.)
No load speed	Max / Hard / Med. / Soft: 0 - 1,200 / 0 - 850 / 0 - 700 / 0 - 600 min ⁻¹
Impacts per minute	Max / Hard / Med. / Soft: 0 - 1,750 / 0 - 1,500 / 0 - 1,300 / 0 - 1,200 min ⁻¹
Dimensions (L x W x H)	570 x 135 x 276 mm (22-1/2 x 5-5/16 x 10-7/8")
Net weight	12.0 - 12.9 kg (26.5 - 28.4 lbs.)

XGT BL MOTOR XPT



40Vmax XGT BL Cordless 3/4" (19 mm) 1,800 N-m (1,330 ft.lbs.) Impact Wrench, Reverse Rotation Auto Stop Mode

TW001G

40V max



Square drive	19.0 mm (3/4")
Max fastening torque	1,800 N-m (1,328 ft.lbs.)
Fastening capacities	Standard bolt: M12 - M36 (1/2 - 1-1/2") High strength bolt: M10 - M27 (3/8 - 1-1/8")
Nut-busting torque	2,050 N-m (1,510 ft.lbs.)
No load speed	Max / Hard / Med. / Soft: 0 - 1,800 / 0 - 1,400 / 0 - 1,150 / 0 - 950 min ⁻¹
Impacts per minute	Max / Hard / Med. / Soft: 0 - 2,500 / 0 - 2,400 / 0 - 2,200 / 0 - 1,900 min ⁻¹
Dimensions (L x W x H)	217 x 94 x 297 - 303 mm (8-1/2 x 3-11/16 x 11-3/4 - 11-7/8")
Net weight	3.9 - 4.2 kg (8.6 - 9.3 lbs.)

XGT BL MOTOR XPT



40Vmax XGT BL Cordless 1/2" (12.7 mm) 1,700 N-m (1,250 ft.lbs.) Impact Wrench, Reverse Rotation Auto Stop Mode

TW002G

40V max



Square drive	12.7 mm (1/2")
Max fastening torque	1,700 N-m (1,250 ft.lbs.)
Fastening capacities	Standard bolt: M12 - M36 (1/2 - 1-1/2") High strength bolt: M10 - M27 (3/8 - 1-1/8")
Nut-busting torque	2,200 N-m (1,620 ft.lbs.)
No load speed	Max / Hard / Med. / Soft: 0 - 1,800 / 0 - 1,000 / 0 - 900 / 0 - 850 min ⁻¹
Impacts per minute	Max / Hard / Med. / Soft: 0 - 2,400 / 0 - 2,000 / 0 - 1,800 / 0 - 1,700 min ⁻¹
Dimensions (L x W x H)	213 x 94 x 297 mm (8-3/8 x 3-11/16 x 11-3/4")
Net weight	3.9 - 5.1 kg (8.6 - 11.2 lbs.)

XGT BL MOTOR XPT



C ring

40Vmax XGT BL Cordless 3/4" (19 mm) 1,500 N-m (1,110 ft.lbs.) Impact Wrench, Forward/Reverse Rotation Auto Stop Mode

TW011G

40V max



Square drive	19.0 mm (3/4")
Max fastening torque	6-sec tightening: 1,500 N-m (1,110 ft.lbs.) 3-sec tightening: 1,250 N-m
Fastening capacities	Standard bolt: M12 - M36 (1/2 - 1-1/2") High strength bolt: M10 - M27 (3/8 - 1-1/8")
Nut-busting torque	1,900 N-m (1,400 ft.lbs.)
No load speed	Max / Hard / Med. / Soft: 0 - 1,800 / 0 - 1,100 / 0 - 700 / 0 - 500 min ⁻¹
Impacts per minute	Max / Hard / Med.: 0 - 2,600 / 0 - 2,000 / 0 - 1,400 min ⁻¹
Dimensions (L x W x H)	329 x 94 x 297 mm (13 x 3-11/16 x 11-3/4")
Net weight	4.3 - 5.5 kg (9.5 - 12.1 lbs.)

XGT BL MOTOR XPT



new

40Vmax XGT BL Cordless 1/2" (12.7 mm) 1,360 N-m (1,000 ft.lbs.) Impact Wrench, Reverse Rotation Auto Stop Mode

TW003G

40V max



Square drive	12.7 mm (1/2")
Max fastening torque	1,360 N-m (1,000 ft.lbs.)
Fastening capacities	Standard bolt: M12 - M36 (1/2 - 1-1/2") High strength bolt: M10 - M27 (3/8 - 1-1/8")
Nut-busting torque	1,600 N-m (1,180 ft.lbs.)
No load speed	Max / Hard / Med. / Soft: 0 - 1,800 / 0 - 1,200 / 0 - 1,000 / 0 - 800 min ⁻¹
Impacts per minute	Max / Hard / Med. / Soft: 0 - 2,400 / 0 - 2,300 / 0 - 2,000 / 0 - 1,600 min ⁻¹
Dimensions (L x W x H)	213 x 94 x 297 mm (8-3/8 x 3-11/16 x 11-3/4")
Net weight	3.8 - 5.0 kg (8.4 - 11.0 lbs.)

XGT BL MOTOR XPT



Pin-detent

40Vmax XGT BL Cordless 1/2" (12.7 mm) 760 N-m (560 ft.lbs.) Impact Wrench, Forward/Reverse Rotation Auto Stop Mode

TW007G / TW008G

40V max



Square drive	12.7 mm (1/2")
Max fastening torque	760 N-m (560 ft.lbs.)
Fastening capacities	Standard bolt: M10 - M24 (3/8 - 1") High strength bolt (Grade 10.9): M10 - M16 (3/8 - 5/8") High strength bolt (Grade F10T): M12, M16 (7/16, 5/8")
Nut-busting torque	1,100 N-m (810 ft.lbs.)
No load speed	Max / Hard / Med. / Soft: 0 - 2,300 / 0 - 1,900 / 0 - 1,200 / 0 - 600 min ⁻¹
Impacts per minute	Max / Hard / Med. / Soft: 0 - 2,900 / 0 - 2,700 / 0 - 1,900 / 0 - 1,200 min ⁻¹
Dimensions (L x W x H)	w/ BL4050F: 170 x 86 x 312 mm (6-11/16 x 3-3/8 x 12-1/4")
Net weight	2.7 - 3.3 kg (6.0 - 7.3 lbs.)

XGT BL MOTOR XPT



TW007G: C ring

TW008G: Pin detent

40Vmax XGT BL Cordless 1/2" (12.7 mm) 350 N-m (260 ft.lbs.) Impact Wrench, Forward/Reverse Rotation Auto Stop Mode

TW004G / TW005G

40V max



Square drive	12.7 mm (1/2")
Max fastening torque	350 N-m (260 ft.lbs.)
Fastening capacities	Standard bolt: M10 - M20 (3/8 - 3/4") High strength bolt: M10 - M16 (3/8 - 5/8")
Nut-busting torque	630 N-m (465 ft.lbs.)
No load speed	Max / Hard / Med. / Soft: 0 - 3,200 / 0 - 2,600 / 0 - 1,800 / 0 - 1,000 min ⁻¹
Impacts per minute	Max / Hard / Med. / Soft: 0 - 4,000 / 0 - 3,400 / 0 - 2,600 / 0 - 1,800 min ⁻¹
Dimensions (L x W x H)	144 x 86 x 248 mm (5-5/8 x 3-3/8 x 9-3/4")
Net weight	1.9 - 2.2 kg (4.2 - 4.9 lbs.)

XGT BL MOTOR XPT



TW004G: C ring

TW005G: Pin detent

Pin detent

18V LXT BL Cordless 3/4" (19 mm) 1,360 N-m (1,000 ft.lbs.) Impact Wrench, Forward/Reverse Rotation Auto Stop Mode

DTW1005

18V



Square drive	19.0 mm (3/4")
Max fastening torque	6-sec tightening: 1,360 N-m (1,000 ft.lbs.) 3-sec tightening: 1,150 N-m
Fastening capacities	Standard bolt: M12 - M33 (1/2" - 1-3/8") High strength bolt: M10 - M24 (3/8" - 1")
Nut-busting torque	1,700 N-m (1,250 ft.lbs.)
No load speed	Max / Hard / Med. / Soft: 0 - 1,800 / 0 - 1,000 / 0 - 900 / 0 - 800 min ⁻¹
Impacts per minute	Max / Hard / Med.: 0 - 2,200 / 0 - 2,000 / 0 - 1,600 min ⁻¹
Dimensions (L x W x H)	339 x 91 x 291 mm (13-3/8 x 3-5/8 x 11-1/4")
Net weight	3.9 - 4.2 kg (8.6 - 9.3 lbs.)

LXT BL MOTOR XPT



new

18V LXT BL Brushless Cordless 3-Speed 3/4" (19 mm) 1,250 N-m (920 ft.lbs.) Impact Wrench

DTW1001

18V



Square drive	19.0 mm (3/4")
Max fastening torque	1,250 N-m (920 ft.lbs.)
Fastening capacities	Standard bolt: M12 - M30 (1/2 - 1-1/4") High strength bolt: M10 - M24 (3/8 - 1")
Nut-busting torque	1,700 N-m (1,250 ft.lbs.)
No load speed	Hard / Med. / Soft: 0 - 1,800 / 0 - 1,000 / 0 - 900 min ⁻¹
Impacts per minute	Hard / Med. / Soft: 0 - 2,200 / 0 - 2,000 / 0 - 1,800 min ⁻¹
Dimensions (L x W x H)	229 x 91 x 289 mm (9 x 3-5/8 x 11-3/8")
Net weight	3.7 kg (8.2 lbs.)

LXT BL MOTOR XPT



C ring

18V LXT BL Brushless Cordless 3-Speed 1/2" (12.7 mm) 1,200 N-m (890 ft.lbs.) Impact Wrench

DTW1002

18V



Square drive	12.7 mm (1/2")
Max fastening torque	1,200 N-m (885 ft.lbs.)
Fastening capacities	Standard bolt: M12 - M30 (1/2 - 1-1/4") High strength bolt: M10 - M24 (3/8 - 1")
Nut-busting torque	1,600 N-m (1,180 ft.lbs.)
No load speed	Hard / Med. / Soft: 0 - 1,800 / 0 - 1,000 / 0 - 900 min ⁻¹
Impacts per minute	Hard / Med. / Soft: 0 - 2,200 / 0 - 2,000 / 0 - 1,800 min ⁻¹
Dimensions (L x W x H)	229 x 91 x 289 mm (9 x 3-5/8 x 11-3/8")
Net weight	3.6 kg (7.9 lbs.)

LXT BL MOTOR XPT



C ring

18V LXT BL Brushless Cordless 3-Speed 1/2" (12.7 mm) Pin-detent Square drive 1,050 N-m (780 ft.lbs.) Impact Wrench

DTW1004

18V



DTW1004:
Pin-detent
Square drive



Square drive	12.7 mm (1/2")
Max fastening torque	1,050 N-m (774 ft.lbs.)
Fastening capacities	Standard bolt: M12 - M30 (1/2 - 1-1/4")
	High strength bolt (Grade 10.9): M10 - M20 (3/8 - 3/4")
	High strength bolt (Grade F10T): M16 - M24 (5/8 - 1")
Nut-busting torque	1,300 N-m (960 ft.lbs.)
No load speed	Hard / Med. / Soft: 0 - 2,000 / 0 - 1,000 / 0 - 900 min ⁻¹
Impacts per minute	Hard / Med. / Soft: 0 - 2,400 / 0 - 2,000 / 0 - 1,800 min ⁻¹
Dimensions (L x W x H)	w/ BL1830B / BL1840B / BL1850B / BL1860B: 223 x 91 x 289 mm (8-3/4 x 3-5/8 x 11-3/8")
	Net weight



18V LXT BL Brushless Cordless 3-Speed 7/16" (11.1 mm) 800 N-m (590 ft.lbs.) Impact Wrench

DTW800

18V



Hex shank	11.1 mm (7/16")
Max fastening torque	800 N-m (590 ft.lbs.)
Fastening capacities	Standard bolt: M12 - M24 (1/2 - 1")
	High strength bolt: M10 - M22 (3/8 - 7/8")
No load speed	Hard / Med. / Soft: 0 - 1,800 / 0 - 1,000 / 0 - 900 min ⁻¹
Impacts per minute	Hard / Med. / Soft: 0 - 2,200 / 0 - 2,000 / 0 - 1,800 min ⁻¹
Dimensions (L x W x H)	229 x 91 x 303 mm (9 x 3-5/8 x 11-7/8")
Net weight	3.4 - 3.7 kg (8.2 - 7.5 lbs.)



18V LXT BL Cordless 1/2" (12.7 mm) 700 N-m (520 ft.lbs.) Impact Wrench, Forward/Reverse Rotation Auto Stop Mode

DTW700 / DTW701

18V



DTW700:
C ring

DTW701:
Pin detent



Square drive	12.7 mm (1/2")
Max fastening torque	700 N-m (520 ft.lbs.)
Fastening capacities	Standard bolt: M10 - M24 (3/8 - 1")
	High strength bolt (Grade 10.9): M10 - M16 (3/8 - 5/8")
	High strength bolt (Grade F10T): M12, M16 (7/16, 5/8")
Nut-busting torque	1,000 N-m (740 ft.lbs.)
No load speed	Max / Hard / Med. / Soft: 0 - 2,200 / 0 - 1,900 / 0 - 1,200 / 0 - 500 min ⁻¹
Impacts per minute	Max / Hard / Med. / Soft: 0 - 2,700 / 0 - 2,400 / 0 - 1,700 / 0 - 1,000 min ⁻¹
Dimensions (L x W x H)	w/ BL1830B / BL1840B / BL1850B / BL1860B: 170 x 81 x 276 mm (6-11/16 x 3-1/16 x 10-7/8")
	Net weight



18V LXT Li-Ion Cordless 1/2" (12.7 mm) 440 N-m (325 ft.lbs.) Impact Wrench

DTW450

18V



Square drive	12.7 mm (1/2")
Max fastening torque	440 N-m (325 ft.lbs.)
Fastening capacities	Standard bolt: M12 - M22 (1/2 - 7/8")
	High strength bolt: M12 - M16 (1/2 - 5/8")
No load speed	1,600 min ⁻¹
Impacts per minute	2,200 min ⁻¹
Dimensions (L x W x H)	266 x 82 x 290 mm (10-1/2 x 3-1/4 x 11-3/8")
Net weight	3.1 - 3.4 kg (7.6 - 6.9 lbs.)



18V LXT BL Cordless 1/2" (12.7 mm) 330 N-m (240 ft.lbs.) Impact Wrench, Forward/Reverse Rotation Auto Stop Mode

DTW300 / DTW301

18V



DTW300:
C ring

DTW301:
Pin detent



Square drive	12.7 mm (1/2")
Max fastening torque	330 N-m (240 ft.lbs.)
Fastening capacities	Standard bolt: M10 - M20 (3/8 - 3/4")
	High strength bolt: M10 - M16 (3/8 - 5/8")
Nut-busting torque	580 N-m (430 ft.lbs.)
No load speed	Max / Hard / Med. / Soft: 0 - 3,200 / 0 - 2,600 / 0 - 1,800 / 0 - 1,000 min ⁻¹
Impacts per minute	Max / Hard / Med. / Soft: 0 - 4,000 / 0 - 3,400 / 0 - 2,600 / 0 - 1,800 min ⁻¹
Dimensions (L x W x H)	144 x 81 x 246 mm (5-5/8 x 3-1/16 x 9-11/16")
Net weight	1.8 kg (4.0 lbs.)



18V LXT BL Cordless 3/8" (9.5 mm) 300 N-m (220 ft.lbs.) Impact Wrench, Forward/Reverse Rotation Auto Stop Mode

DTW302

18V



Square drive	9.5 mm (3/8")
Max fastening torque	300 N-m (220 ft.lbs.)
Fastening capacities	Standard bolt: M10 - M20 (3/8 - 3/4")
	High strength bolt: M10 - M16 (3/8 - 5/8")
Nut-busting torque	500 N-m (370 ft.lbs.)
No load speed	Max / Hard / Med. / Soft: 0 - 3,200 / 0 - 2,600 / 0 - 1,800 / 0 - 1,000 min ⁻¹
Impacts per minute	Max / Hard / Med. / Soft: 0 - 4,000 / 0 - 3,400 / 0 - 2,600 / 0 - 1,800 min ⁻¹
Dimensions (L x W x H)	138 x 81 x 246 mm (5-7/16 x 3-1/16 x 9-11/16")
Net weight	1.8 kg (4.0 lbs.)



18V LXT Li-Ion Cordless 1/2" (12.7 mm) 230 N-m (170 ft.lbs.) Impact Wrench

DTW251

18V



Square drive	12.7 mm (1/2")
Max fastening torque	230 N-m (170 ft.lbs.)
Fastening capacities	Standard bolt: M10 - M16 (3/8 - 5/8")
	High strength bolt: M10 - M14 (3/8 - 9/16")
	High strength bolt: M10 - M14 (3/8 - 9/16")
No load speed	0 - 3,200 min ⁻¹
Impacts per minute	0 - 3,200 min ⁻¹
Dimensions (L x W x H)	165 x 79 x 234 mm (6-1/2 x 3-1/8 x 9-1/4")
Net weight	1.5 - 1.8 kg (3.2 - 3.9 lbs.)



18V LXT BL Brushless Cordless 1/2" (12.7 mm) 210 N-m (155 ft.lbs.) Impact Wrench, Reverse Rotation Auto Stop Mode

DTW181

18V



Square drive	12.7 mm (1/2")
Max fastening torque	210 N-m (155 ft.lbs.)
Fastening capacities	Standard bolt: M8 - M16 (5/16 - 5/8")
	High strength bolt: M6 - M12 (1/4 - 1/2")
Nut-busting torque	330 N-m (245 ft.lbs.)
No load speed	Hard / Soft: 0 - 2,400 / 0 - 1,300 min ⁻¹
Impacts per minute	Hard / Soft: 0 - 3,600 / 0 - 2,000 min ⁻¹
Dimensions (L x W x H)	w/ BL1830B / BL1840B / BL1850B / BL1860B: 151 x 79 x 235 mm (5-15/16 x 3-1/8 x 9-1/4")
Net weight	1.2 - 1.5 kg (2.7 - 3.4 lbs.)



18V LXT Li-Ion Cordless 3/8" (9.5 mm) 210 N-m (155 ft.lbs.) Impact Wrench

DTW253

18V



Square drive	9.5 mm (3/8")
Max fastening torque	210 N-m (155 ft.lbs.)
Fastening capacities	Standard bolt: M8 - M16 (5/16 - 5/8")
	High strength bolt: M6 - M12 (1/4 - 1/2")
	High strength bolt: M6 - M12 (1/4 - 1/2")
No load speed	0 - 2,100 min ⁻¹
Impacts per minute	0 - 3,200 min ⁻¹
Dimensions (L x W x H)	155 x 79 x 234 mm (6-1/8 x 3-1/8 x 9-1/4")
Net weight	1.3 - 1.6 kg (2.8 - 3.6 lbs.)



18V LXT Li-Ion Cordless 1/2" (12.7 mm) 190 N-m (140 ft.lbs.) Impact Wrench

DTW190

18V



Square drive	12.7 mm (1/2")
Max fastening torque	190 N-m (140 ft.lbs.)
Fastening capacities	Standard bolt: M8 - M16 (5/16 - 5/8")
	High strength bolt: M8 - M12 (5/16 - 1/2")
No load speed	0 - 2,300 min ⁻¹
Impacts per minute	0 - 3,000 min ⁻¹
Overall length	176 mm (6-15/16")
Net weight	1.4 - 1.8 kg (3.2 - 3.9 lbs.)



Screwing/Drilling

18V LXT BL Brushless Cordless 3/8" (9.5 mm) 180 N-m (130 ft.lbs.) Impact Wrench, Reverse Rotation Auto Stop Mode**DTW180**

18V



Square drive	9.5 mm (3/8")
Max fastening torque	180 N-m (130 ft.lbs.)
Fastening capacities	Standard bolt: M8 - M16 (5/16 - 5/8")
	High strength bolt: M6 - M12 (1/4 - 1/2")
	310 N-m (230 ft.lbs.)
Nut-busting torque	310 N-m (230 ft.lbs.)
No load speed	Hard / Soft: 0 - 2,400 / 0 - 1,300 min ⁻¹
Impacts per minute	Hard / Soft: 0 - 3,600 / 0 - 2,000 min ⁻¹
Dimensions (L x W x H)	w/ BL1830B / BL1840B / BL1850B / BL1860B: 144 x 79 x 235 mm (5-5/8 x 3-1/8 x 9-1/4")
Net weight	1.2 - 1.5 kg (2.7 - 3.4 lbs.)

LXT BL MOTOR XPT

**12Vmax CXT BL Brushless Cordless 1/2" (12.7 mm) 165 N-m (122 ft.lbs.) Impact Wrench****TW161D**

12V max



Square drive	12.7 mm (1/2")
Max fastening torque	165 N-m (122 ft.lbs.)
Fastening capacities	Standard bolt: M8 - M16 (5/16 - 5/8")
	High strength bolt: M6 - M12 (1/4 - 1/2")
	310 N-m (230 ft.lbs.)
No load speed	Hard / Soft: 0 - 2,400 / 0 - 1,300 min ⁻¹
Impacts per minute	Hard / Soft: 0 - 3,600 / 0 - 2,000 min ⁻¹
Dimensions (L x W x H)	w/ BL1041B: 150 x 66 x 232 mm (5-7/8 x 2-5/8 x 9-1/8")
Net weight	1.1 - 1.2 kg (2.4 - 2.7 lbs.)

CXT BL MOTOR

**12Vmax CXT BL Brushless Cordless 3/8" (9.5 mm) 160 N-m (120 ft.lbs.) Impact Wrench****TW160D**

12V max



Square drive	9.5 mm (3/8")
Max fastening torque	160 N-m (120 ft.lbs.)
Fastening capacities	Standard bolt: M8 - M16 (5/16 - 5/8")
	High strength bolt: M6 - M12 (1/4 - 1/2")
	290 N-m (210 ft.lbs.)
Nut-busting torque	290 N-m (210 ft.lbs.)
No load speed	Hard / Soft: 0 - 2,400 / 0 - 1,300 min ⁻¹
Impacts per minute	Hard / Soft: 0 - 3,600 / 0 - 2,000 min ⁻¹
Dimensions (L x W x H)	w/ BL1041B: 144 x 66 x 232 mm (5-5/8 x 2-5/8 x 9-1/8")
Net weight	1.0 - 1.2 kg (2.2 - 2.6 lbs.)

CXT BL MOTOR

**12Vmax CXT Li-Ion Cordless 1/2" (12.7 mm) 145 N-m (107 ft.lbs.) Impact Wrench****TW141D**

12V max



Square drive	12.7 mm (1/2")
Max fastening torque	145 N-m (107 ft.lbs.)
Fastening capacities	Standard bolt: M8 - M16 (5/16 - 5/8")
	High strength bolt: M6 - M12 (1/4 - 1/2")
	270 N-m (200 ft.lbs.)
Nut-busting torque	270 N-m (200 ft.lbs.)
No load speed	0 - 2,600 min ⁻¹
Impacts per minute	0 - 3,200 min ⁻¹
Dimensions (L x W x H)	w/ BL1041B: 168 x 66 x 224 mm (6-5/8 x 2-5/8 x 8-7/8")
Net weight	1.1 - 1.2 kg (2.4 - 2.7 lbs.)

CXT

**12Vmax CXT Li-Ion Cordless 3/8" (9.5 mm) 140 N-m (100 ft.lbs.) Impact Wrench****TW140D**

12V max



Square drive	9.5 mm (3/8")
Max fastening torque	140 N-m (100 ft.lbs.)
Fastening capacities	Standard bolt: M8 - M16 (5/16 - 5/8")
	High strength bolt: M6 - M12 (1/4 - 1/2")
	270 N-m (200 ft.lbs.)
Nut-busting torque	270 N-m (200 ft.lbs.)
No load speed	0 - 2,600 min ⁻¹
Impacts per minute	0 - 3,200 min ⁻¹
Dimensions (L x W x H)	w/ BL1041B: 161 x 66 x 224 mm (6-3/8 x 2-5/8 x 8-7/8")
Net weight	1 - 1.2 kg (2.3 - 2.7 lbs.)

CXT

**12Vmax CXT Li-Ion Cordless 1/4" (6.35 mm) 60 N-m (44 ft.lbs.) Impact Wrench****TW060D**

12V max



Square drive	6.35 mm (1/4")
Max fastening torque	60 N-m (44 ft.lbs.)
Fastening capacities	Standard bolt: M8 - M12 (5/16 - 15/32")
	High strength bolt: M6 - M10 (1/4 - 3/8")
	120 N-m (90 ft.lbs.)
Nut-busting torque	120 N-m (90 ft.lbs.)
No load speed	0 - 2,600 min ⁻¹
Impacts per minute	0 - 3,200 min ⁻¹
Dimensions (L x W x H)	w/ BL1041B: 161 x 66 x 224 mm (6-3/8 x 2-5/8 x 8-7/8")
Net weight	1.0 - 1.2 kg (2.2 - 2.6 lbs.)

CXT

**10.8V (12V max) Li-Ion Cordless 3/8" (9.5 mm) 110 N-m (1,000 in.lbs.) Impact Wrench****TW100D**

10.8V



Square drive	9.5 mm (3/8")
Max fastening torque	110 N-m (1,000 in.lbs.)
Fastening capacities	Standard bolt: M8 - M12 (5/16 - 1/2")
	High strength bolt: M6 - M10 (1/4 - 3/8")
	320 N-m (236 ft.lbs.)
Nut-busting torque	320 N-m (236 ft.lbs.)
No load speed	0 - 3,000 min ⁻¹
Impacts per minute	0 - 3,000 min ⁻¹
Dimensions (L x W x H)	163 x 54 x 178 mm (6-3/8 x 2-1/8 x 7")
Net weight	0.95 kg (2.1 lbs.)

**18V Li-Ion Cordless 1/2" (12.7 mm) 200 N-m (148 ft.lbs.) Impact Wrench, G-Battery****TW202D**

18V



Square drive	12.7 mm (1/2")
Max fastening torque	200 N-m (148 ft.lbs.)
Fastening capacities	Standard bolt: M8 - M16 (5/16 - 5/8")
	High strength bolt: M8 - M12 (5/16 - 1/2")
	320 N-m (236 ft.lbs.)
Nut-busting torque	320 N-m (236 ft.lbs.)
No load speed	0 - 3,000 min ⁻¹
Impacts per minute	0 - 3,000 min ⁻¹
Dimensions (L x W x H)	w/ BL1811G / BL1813G / BL1815G / BL1820G: 176 x 79 x 223 mm (6-15/16 x 3-1/8 x 8-3/4")
Net weight	1.5 kg (3.3 lbs.)

**1" (25.4 mm) 1,000 N-m (738 ft.lbs.) Impact Wrench****TW1000**

Continuous rating	1,200W
Input	
Capacity	Standard bolt: M24 - M30 (15/16 - 1-3/16")
	High strength bolt: M22 - M24 (7/8 - 15/16")
Square drive	25.4 mm (1")
Max fastening torque	1,000 N-m (738 ft.lbs.)
No load speed	1,400 min ⁻¹
Impacts per minute	1,500 min ⁻¹
Dimensions (L x W x H)	382 x 110 x 290 mm (15 x 4-5/16 x 11-3/8")
Net weight	8.8 kg (19.4 lbs.)

**3/4" (19 mm) 588 N-m (441 ft.lbs.) Impact Wrench****6906**

Continuous rating	850W
Input	
Capacity	Standard bolt: M16 - M22 (5/8 - 7/8")
	High strength bolt: M16 - M20 (5/8 - 3/4")
Square drive	19 mm (3/4")
Max fastening torque	588 N-m (441 ft.lbs.)
No load speed	1,700 min ⁻¹
Impacts per minute	1,600 min ⁻¹
Overall length	327 mm (12-7/8")
Net weight	5.6 kg (12.2 lbs.)



1/2" (12.7 mm) 294 N-m (217 ft.lbs.) Impact Wrench

6905H



Continuous rating	470W
Input	
Capacity	Standard bolt: M12 - M20 (1/2 - 3/4") High strength bolt: M12 - M16 (1/2 - 5/8")
Square drive	12.7 mm (1/2")
Max fastening torque	294 N-m (217 ft.lbs.)
No load speed	2,200 min ⁻¹
Impacts per minute	2,600 min ⁻¹
Dimensions (L x W x H)	275 x 86 x 197 mm (10-7/8 x 3-3/8 x 7-3/4")
Net weight	2.4 kg (5.2 lbs.)



1/2" (12.7 mm) 350 N-m (260 ft.lbs.) Impact Wrench

TW0350



Continuous rating	400W
Input	
Capacity	Standard bolt: M12 - M22 (1/2 - 7/8") High strength bolt: M12 - M16 (1/2 - 5/8")
Square drive	12.7 mm (1/2")
Max fastening torque	350 N-m (260 ft.lbs.)
No load speed	2,000 min ⁻¹
Impacts per minute	2,000 min ⁻¹
Dimensions (L x W x H)	283 x 87 x 233 mm (11-1/8 x 3-7/16 x 9-1/8")
Net weight	3 kg (6.6 lbs.)



1/2" (12.7 mm) 200 N-m (150 ft.lbs.) Impact Wrench

TW0200



Continuous rating	380W
Input	
Capacity	Standard bolt: M10 - M16 (3/8 - 5/8") High strength bolt: M10 - M12 (3/8 - 1/2")
Square drive	12.7 mm (1/2")
Max fastening torque	200 N-m (150 ft.lbs.)
No load speed	0 - 2,200 min ⁻¹
Impacts per minute	0 - 2,200 min ⁻¹
Dimensions (L x W x H)	251 x 72 x 220 mm (9-7/8 x 2-13/16 x 8-5/8")
Net weight	2.1 kg (4.7 lbs.)



1/2" (12.7 mm) 150 N-m (110 ft.lbs.) Impact Wrench

6953



Continuous rating	280W
Input	
Capacity	Standard bolt: M10 - M16 (3/8 - 5/8") High strength bolt: M8 - M12 (5/16 - 1/2")
Square drive	12.7 mm (1/2")
Max fastening torque	150 N-m (111 ft.lbs.)
No load speed	0 - 3,000 min ⁻¹
Impacts per minute	0 - 3,000 min ⁻¹
Overall length	233 mm (9-1/8")
Net weight	1.5 kg (3.2 lbs.)



18V LXT Li-Ion Cordless 47.5 N-m (420 in.lbs.) Ratchet Wrench

DWR180

18V



Capacity	Standard bolt: M5 - M12 (3/16 - 1/2") High strength bolt: M5 - M10 (3/16 - 3/8")
Square drive	9.5 / 6.35 mm (3/8 / 1/4")
Max fastening torque	47.5 N-m (420 in.lbs.)
No load speed	0 - 800 min ⁻¹
Flats width	13 mm (1/2")
Angle head size	Diameter: 31 mm (1-7/32") Height: 25.5 mm (1")
Dimensions (L x W x H)	w/ BL1830B / BL1840B / BL1850B / BL1860B: 369 x 79 x 87 mm (14-1/2 x 3-1/8 x 3-7/16")
Net weight	1.2 - 1.6 kg (2.6 - 3.5 lbs.)

LXT XPT



12Vmax CXT Li-Ion Cordless 47.5 N-m (420 in.lbs.) Ratchet Wrench

WR100D

12V max



Capacity	Standard bolt: M5 - M12 (3/16 - 1/2") High strength bolt: M5 - M10 (3/16 - 3/8")
Square drive	9.5 / 6.35 mm (3/8 / 1/4")
Max fastening torque	47.5 N-m (420 in.lbs.)
No load speed	0 - 800 min ⁻¹
Flats width	13 mm (1/2")
Angle head size	Diameter: 31 mm (1-7/32") Height: 25.5 mm (1")
Dimensions (L x W x H)	w/ BL1041B: 341 x 67 x 84 mm (13-7/16 x 2-5/8 x 3-5/16")
Net weight	1.0 - 1.2 kg (2.3 - 2.7 lbs.)

CXT XPT



18V LXT Li-Ion Brushless Cordless Angle Impact Wrench

DTL300 / DTL301

18V

new



DTL300: C ring DTL301: Pin detent

Max fastening torque	310 - 340 N-m (230 - 250 ft.lbs.)
Nut-busting torque	500 - 530 N-m (370 - 390 ft.lbs.)
Square drive	12.7 mm (1/2")
No load speed	Hard / Med. / Soft: 0 - 3,200 / 0 - 1,500 / 0 - 1,000 min ⁻¹
Impacts per minute	Hard / Med. / Soft: 0 - 4,000 / 0 - 2,800 / 0 - 1,800 min ⁻¹
Dimensions (L x W x H)	396 - 414 x 80 x 86 - 92 mm (15-5/8 - 16-1/4 x 3-1/8 x 3-3/8 - 3-5/8")
Net weight	1.8 - 2.1 kg (4.0 - 4.6 lbs.)

LXT MOTOR XPT



18V LXT Li-Ion Brushless Cordless Angle Impact Wrench

DTL302

18V

new



Max fastening torque	310 - 340 N-m (230 - 250 ft.lbs.)
Nut-busting torque	500 - 530 N-m (370 - 390 ft.lbs.)
Square drive	9.5 mm (3/8")
No load speed	Hard / Med. / Soft: 0 - 3,200 / 0 - 1,500 / 0 - 1,000 min ⁻¹
Impacts per minute	Hard / Med. / Soft: 0 - 4,000 / 0 - 2,800 / 0 - 1,800 min ⁻¹
Dimensions (L x W x H)	396 - 414 x 80 x 86 - 92 mm (15-5/8 - 16-1/4 x 3-1/8 x 3-3/8 - 3-5/8")
Net weight	1.8 - 2.1 kg (4.0 - 4.6 lbs.)

LXT MOTOR XPT



18V LXT Li-Ion Cordless 3/8" (9.5 mm) 60 N-m Angle Impact Wrench

DTL063

18V



Capacity	Standard bolt: M4 - M12 (5/32 - 1/2") High strength bolt: M4 - M8 (5/32 - 5/16")
Max fastening torque	60 N-m (N/A ft.lbs.)
Square drive	9.5 mm (3/8")
No load speed	0 - 2,000 min ⁻¹
Impacts per minute	0 - 3,000 min ⁻¹
Dimensions (L x W x H)	387 x 78 x 116 mm (15-1/4 x 3-1/16 x 4-9/16")
Net weight	1.4 - 2 kg (3.1 - 4.3 lbs.)

LXT



12Vmax CXT Li-Ion Cordless 60 N-m (530 in.lbs.) Angle Impact Wrench

TL065D

12V max



Capacity	Standard bolt: M4-M12 (5/32-1/2") High strength bolt: M4-M8 (5/32-5/16")
Max fastening torque	60 N-m (530 in.lbs.)
Square drive	9.5 mm (3/8")
No load speed	0 - 2,000 min ⁻¹
Impacts per minute	0 - 3,000 min ⁻¹
Dimensions (L x W x H)	361 x 66 x 86 mm (14-1/4 x 2-5/8 x 3-3/8")
Net weight	1.2 - 1.6 kg (2.7 - 3.6 lbs.)

CXT



Screwing/Drilling

Screwing/Drilling

40Vmax XGT BL Brushless Cordless M16 (5/8") / M20 (3/4") / M22 (7/8") 804 N-m (593 ft.lbs.) Shear Wrench

WT001G

40V max



Capacity	Bolt: M16, M20, M22 (5/8, 3/4, 7/8")
No load speed	17 min ⁻¹
Max fastening torque	804 N-m (593 ft.lbs.)
Dimensions (L x W x H)	w/ M22 Sleeve, w/ BL4040: 270 x 95 x 340 mm (10-5/8 x 3-3/4 x 13-3/8")
Net weight	5.2 - 5.9 kg (11.5 - 13 lbs.)



18V X2 (36V) LXT BL Brushless Cordless M16 (5/8") / M20 (3/4") / M22 (7/8") 804 N-m (593 ft.lbs.) Shear Wrench

DWT310

18V x2



Capacity	Bolt: M16, M20, M22 (5/8, 3/4, 7/8")
No load speed	14 min ⁻¹
Max fastening torque	804 N-m (593 ft.lbs.)
Dimensions (L x W x H)	296 x 130 x 377 mm (11-5/8 x 5-1/8 x 14-7/8")
Net weight	6.5 - 7.1 kg (14.3 - 15.7 lbs.)



M22 (7/8") / M24 (1") / SHTB22 1,100 N-m (810 ft.lbs.) Shear Wrench

6924N



Continuous rating	1,050W
Input	
Capacity	Bolt: M22, M24 (7/8, 1")
No load speed	19 min ⁻¹
Max fastening torque	1,100 N-m (810 ft.lbs.)
Dimensions (L x W x H)	330 x 104 x 257 mm (13 x 4-1/8 x 10-1/8")
Net weight	7.5 kg (16.6 lbs.)



M16 (5/8") / M20 (3/4") / M22 (7/8") 804 N-m (593 ft.lbs.) Shear Wrench

6922NB



Continuous rating	1,330W
Input	
Capacity	Bolt: M16, M20, M22 (5/8, 3/4, 7/8")
No load speed	18 min ⁻¹
Max fastening torque	804 N-m (593 ft.lbs.)
Dimensions (L x W x H)	249 x 84 x 252 mm (9-3/4 x 3-5/16 x 9-7/8")
Net weight	4.8 kg (10.6 lbs.)



82 mm (3-1/8") 1,300 W Diamond Core Drill, Dry

DBM080



Continuous rating	1,300W
Input	
Capacity	Concrete (w/ Diamond core bit): 82 mm (3-1/4")
Tool holder	(Spindle): M18
No load speed	0 - 3,400 min ⁻¹
Net weight	3.4 kg (7.5 lbs.)



132 mm (5-3/16") 1,700 W Diamond Core Drill, Dry

DBM130



Continuous rating	1,700W
Input	
Capacity	Concrete (w/ Diamond core bit), Hi: 70 mm (2-3/4") Concrete (w/ Diamond core bit), Lo: 132 mm (5-3/16")
Tool holder	(Spindle): M18
No load speed	High: 0 - 3,000 min ⁻¹ Low: 0 - 1,500 min ⁻¹
Net weight	5.5 kg (12.1 lbs.)



230 mm (9") 2,500 W Diamond Core Drill

DBM230



Continuous rating	2,500W
Input	
Capacity	Concrete (w/ Diamond core bit): 230 mm (9")
No load speed	3rd: 1,700 min ⁻¹ 2nd: 1,040 min ⁻¹ 1st: 390 min ⁻¹
Net weight	37.5 kg (82.7 lbs.)



132 mm (5-3/16") 1,700 W Diamond Core Drill, Wet & Dry

DBM131



Continuous rating	1,700W
Input	
Capacity	Concrete (w/ Diamond core bit), Hi: 70 mm (2-3/4") Concrete (w/ Diamond core bit), Lo: 132 mm (5-3/16")
Tool holder	(Spindle): M18
No load speed	High: 0 - 2,300 min ⁻¹ Low: 0 - 1,100 min ⁻¹
Net weight	6.3 kg (13.9 lbs.)



40Vmax XGT BL ADT Cordless Earth Auger

DG002G

40V max



Max drilling capacity	200 mm
Capacity	Clay soil, High: 60 mm Clay soil, Low: 150 mm Sandy soil, High: 60 mm Sandy soil, Low: 200 mm
No load speed	High: 0 - 1,500 min ⁻¹ Low: 0 - 400 min ⁻¹
Max torque	High: 55 N-m (487 in.lbs) Low: 136 N-m (1,210 in.lbs)
Dimensions (L x W x H)	w/ BL4040: 842 x 605 x 194 mm (33-1/4 x 23-3/4 x 7-5/8")
Net weight	6.8 - 8.0 kg (15.0 - 17.6 lbs.)



40Vmax XGT BL ADT Cordless Earth Auger

DG001G

40V max



Max drilling capacity	200 mm
Capacity	Clay soil: 150 mm Sandy soil: 200 mm
Chuck capacity	2 - 13 mm (1/16 - 1/2")
No load speed	High: 0 - 1,500 min ⁻¹ Low: 0 - 400 min ⁻¹
Max torque	High: 55 N-m (487 in.lbs) Low: 136 N-m (1,210 in.lbs)
Dimensions (L x W x H)	w/ BL4050F: 863 x 605 x 199 mm (34 x 23-3/4 x 7-7/8")
Net weight	7.2 - 8.1 kg (15.9 - 17.9 lbs.)



18V X2 (36V) LXT BL ADT Cordless Earth Auger

DDG461

18V x2



Max drilling capacity	200 mm
Capacity	Clay soil, High: 60 mm Clay soil, Low: 150 mm Sandy soil, High: 60 mm Sandy soil, Low: 200 mm
No load speed	High: 0 - 1,400 min ⁻¹ Low: 0 - 350 min ⁻¹
Max torque	High: 48 N-m (430 in.lbs) Low: 136 N-m (1,210 in.lbs)
Dimensions (L x W x H)	w/ BL1830B / BL1840B / BL1850B / BL1860B: 840 x 607 x 223 mm (33 x 23-7/8 x 8-3/4")
Net weight	7.0 - 7.6 kg (15.4 - 16.8 lbs.)



18V X2 (36V) LXT BL ADT Cordless Earth Auger

DDG460

18V x2



Capacity	Clay soil: 150 mm Sandy soil: 200 mm
Chuck capacity	2 - 13 mm (5/64 - 1/2")
No load speed	High: 0 - 1,400 min ⁻¹ Low: 0 - 350 min ⁻¹
Dimensions (L x W x H)	w/ BL1830B / BL1840B / BL1850B / BL1860B: 840 x 607 x 223 mm (33 x 23-7/8 x 8-3/4")
Net weight	7.3 - 8.2 kg (16.1 - 18.1 lbs.)



18V LXT BL Brushless Cordless 0-4,000 RPM Push Drive Technology Screwdriver, LED Light, Silent Clutch

DFS452

18V



Capacity	Self-drilling screw: 6 mm (1/4") Drywall screw: 5 mm (3/16")
Driving shank (Hex)	6.35 mm (1/4")
No load speed	0 - 4,000 min ⁻¹
Dimensions (L x W x H)	251 x 79 x 259 mm (10 x 3-1/8 x 11-1/4")
Net weight	1.5 - 1.8 kg (3.2 - 3.9 lbs.)



18V LXT Li-Ion Cordless 0-4,000 RPM Screwdriver with LED Light, Silent Clutch

DFS451

18V



Capacity	Drywall screw: 4 mm (5/32")
Driving shank (Hex)	6.35 mm (1/4")
No load speed	0 - 4,000 min ⁻¹
Dimensions (L x W x H)	281 x 80 x 241 mm (11-1/8 x 3-1/8 x 9-1/2")
Net weight	1.5 - 1.8 kg (3.2 - 4 lbs.)



18V LXT BL Brushless Cordless 0-2,500 RPM High Torque Push Drive Technology Screwdriver with LED Light, Silent Clutch

DFS250

18V



Capacity	Coarse thread: 4.5 x 90 mm (3/16 x 3-1/2") Self-drilling screw: 6 mm (1/4") Drywall screw: 5 mm (3/16")
Driving shank (Hex)	6.35 mm (1/4")
No load speed	0 - 2,500 min ⁻¹
Dimensions (L x W x H)	259 x 79 x 259 mm (10-1/4 x 3-1/8 x 10-1/4")
Net weight	1.5 - 1.9 kg (3.4 - 4.1 lbs.)



18V LXT BL Brushless Cordless 0-2,500 RPM High Torque Push Drive Technology Screwdriver with LED Light

DFS251

18V



Capacity	Self-drilling screw: 6 mm (1/4") Drywall screw: 5 mm (3/16") Hex socket screw: 6 mm (1/4")
Driving shank (Hex)	6.35 mm (1/4")
No load speed	0 - 2,500 min ⁻¹
Dimensions (L x W x H)	237 x 79 x 259 mm (9-3/8 x 3-1/8 x 11-1/4")
Net weight	1.5 - 1.8 kg (3.2 - 3.9 lbs.)



570 W 0-2,500 RPM 6 Stage Adjustable Torque Screwdriver with LED Light

FS2700



Continuous rating Input	570W
Capacity	Self-drilling screw: 6 mm (1/4") Machine screw: 8 mm (5/16") Wood screw: 6.2 mm (1/4")
Driving shank (Hex)	6.35 mm (1/4")
No load speed	0 - 2,500 min ⁻¹
Dimensions (L x W x H)	301 x 70 x 207 mm (11-7/8 x 2-3/4 x 8-1/8")
Net weight	1.8 kg (4 lbs.)



570 W 0-2,500 RPM 6 Stage Adjustable Torque Screwdriver with LED Light

FS2701



Continuous rating Input	570W
Capacity	Self-drilling screw: 6 mm (1/4") Machine screw: 8 mm (5/16") Wood screw: 6.2 mm (1/4")
Driving shank (Hex)	6.35 mm (1/4")
No load speed	0 - 2,500 min ⁻¹
Dimensions (L x W x H)	283 x 70 x 207 mm (11-1/8 x 2-3/4 x 8-1/8")
Net weight	1.7 kg (3.8 lbs.)



570 W 0-2,500 RPM Screwdriver with LED Light

FS2500



Continuous rating Input	570W
Capacity	Drywall screw: 5 mm (3/16") Self-drilling screw: 6 mm (1/4")
Driving shank (Hex)	6.35 mm (1/4")
No load speed	0 - 2,500 min ⁻¹
Dimensions (L x W x H)	280 x 70 x 207 mm (11 x 2-3/4 x 8-1/8")
Net weight	1.5 kg (3.4 lbs.)



Screwing/Drilling

18V LXT BL Cordless 0-6,000 RPM 41 mm (1-5/8") Auto Feed Screwdriver with Silent Clutch**DFR452**

18V



Screw strip	3.5-4.2 x 20-41 mm (1/8-5/32 x 13/16-1-5/8")
Driving shank (Hex)	6.35 mm (1/4")
No load speed	0 - 6,000 min ⁻¹
Dimensions (L x W x H)	w/ BL1830B / BL1840B / BL1850B / BL1860B: 360 x 88 x 211 mm (14-1/8 x 3-1/2 x 8-5/16")
Net weight	1.9-2.2 kg (4.2-4.9 lbs.)

LXT BL MOTOR XPT**18V LXT BL Cordless 0-6,000 RPM 55 mm (2-3/16") Auto Feed Screwdriver with Silent Clutch****DFR551**

18V



Screw strip	3.5-4.2 x 25-55 mm (1/8-5/32 x 1-2-3/16")
Driving shank (Hex)	6.35 mm (1/4")
No load speed	0 - 6,000 min ⁻¹
Dimensions (L x W x H)	w/ BL1830B / BL1840B / BL1850B / BL1860B: 396 x 88 x 211 mm (15-5/8 x 3-1/2 x 8-5/16")
Net weight	1.9-2.2 kg (4.2-4.9 lbs.)

LXT BL MOTOR XPT**18V LXT BL Cordless 0-4,500 RPM 41 mm (1-5/8") Auto Feed Screwdriver with Silent Clutch****DFR453**

18V



Screw strip	3.5-4.2 x 20-41 mm (1/8-5/32 x 13/16-1-5/8")
Driving shank (Hex)	6.35 mm (1/4")
No load speed	0 - 4,500 min ⁻¹
Dimensions (L x W x H)	w/ BL1830B / BL1840B / BL1850B / BL1860B: 360 x 88 x 211 mm (14-1/8 x 3-1/2 x 8-5/16")
Net weight	1.9-2.2 kg (4.2-4.9 lbs.)

LXT BL MOTOR XPT**18V LXT BL Cordless 0-4,500 RPM 55 mm (2-3/16") Auto Feed Screwdriver with Silent Clutch****DFR552**

18V



Screw strip	3.5-4.2 x 25-55 mm (1/8-5/32 x 1-2-3/16")
Driving shank (Hex)	6.35 mm (1/4")
No load speed	0 - 4,500 min ⁻¹
Dimensions (L x W x H)	w/ BL1830B / BL1840B / BL1850B / BL1860B: 396 x 88 x 211 mm (15-5/8 x 3-1/2 x 8-5/16")
Net weight	1.9-2.2 kg (4.2-4.9 lbs.)

LXT BL MOTOR XPT**18V LXT Li-Ion Cordless 4,000 RPM 55 mm (2-3/16") Auto Feed Screwdriver with Silent Clutch****DFR550**

18V



Screw strip	4 x 25 - 55 mm (5/32 x 1 - 2-3/16")
Driving shank (Hex)	6.35 mm (1/4")
No load speed	4,000 min ⁻¹
Dimensions (L x W x H)	424 x 80 x 238 mm (16-3/4 x 3-1/8 x 9-3/8")
Net weight	2.1 - 3.1 kg (4.6 - 6.9 lbs.)

LXT**18V LXT Li-Ion Cordless 4,000 RPM 75 mm (2-15/16") Auto Feed Screwdriver with Silent Clutch****DFR750**

18V



Screw strip	4 x 45-75 mm (5/32 x 1-3/4-2-15/16")
Driving shank (Hex)	6.35 mm (1/4")
No load speed	4,000 min ⁻¹
Dimensions (L x W x H)	464 x 80 x 238 mm (18-1/4 x 3-1/8 x 9-3/8")
Net weight	2.1-3.2 kg (4.6-7 lbs.)

LXT**570 W 0-4,000 RPM Drywall Screwdriver with LED Light, Silent Clutch****FS4300**

Continuous rating Input	570W
Capacity	Drywall screw: 5 mm (3/16") Self-drilling screw: 6 mm (1/4")
Driving shank (Hex)	6.35 mm (1/4")
No load speed	0 - 4,000 min ⁻¹
Dimensions (L x W x H)	279 x 65 x 207 mm (11 x 2-9/16 x 8-1/8")
Net weight	1.4 kg (3.1 lbs.)

**570 W 0-4,000 RPM Drywall Screwdriver with LED Light****FS4200**

Continuous rating Input	570W
Capacity	Drywall screw: 5 mm (3/16") Self-drilling screw: 6 mm (1/4")
Driving shank (Hex)	6.35 mm (1/4")
No load speed	0 - 4,000 min ⁻¹
Dimensions (L x W x H)	269 x 65 x 207 mm (10-5/8 x 2-9/16 x 8-1/8")
Net weight	1.4 kg (3 lbs.)

**570 W 0-4,000 RPM Drywall Screwdriver****FS4000**

Continuous rating Input	570W
Capacity	Drywall screw: 5 mm (3/16") Self-drilling screw: 6 mm (1/4")
Driving shank (Hex)	6.35 mm (1/4")
No load speed	0 - 4,000 min ⁻¹
Dimensions (L x W x H)	269 x 65 x 207 mm (10-5/8 x 2-9/16 x 8-1/8")
Net weight	1.3 kg (2.9 lbs.)

**570 W 0-2,500 RPM Drywall Screwdriver with LED Light, Silent Clutch****FS2300**

Continuous rating Input	570W
Capacity	Drywall screw: 5 mm (3/16") Self-drilling screw: 6 mm (1/4")
Driving shank (Hex)	6.35 mm (1/4")
No load speed	0 - 2,500 min ⁻¹
Dimensions (L x W x H)	290 x 70 x 207 mm (11-3/8 x 2-3/4 x 8-1/8")
Net weight	1.6 kg (3.5 lbs.)



570 W 0-2,500 RPM Drywall Screwdriver with LED Light

FS2200



Continuous rating	570W
Input	
Capacity	Drywall screw: 5 mm (3/16") Self-drilling screw: 6 mm (1/4")
Driving shank (Hex)	6.35 mm (1/4")
No load speed	0 - 2,500 min ⁻¹
Dimensions (L x W x H)	287 x 70 x 207 mm (11-1/4 x 2-3/4 x 8-1/8")
Net weight	1.6 kg (3.5 lbs.)



570 W 0-6,000 RPM Drywall Screwdriver with LED Light, Silent Clutch, 15 m (50') Detachable Cord

FS6300R



Continuous rating	570W
Input	
Capacity	Drywall screw: 4 mm (5/32")
Driving shank (Hex)	6.35 mm (1/4")
No load speed	0 - 6,000 min ⁻¹
Dimensions (L x W x H)	279 x 65 x 207 mm (11 x 2-9/16 x 8-1/8")
Net weight	1.4 kg (3.1 lbs.)



570 W 0-6,000 RPM Drywall Screwdriver with LED Light, Silent Clutch

FS6300



Continuous rating	570W
Input	
Capacity	Drywall screw: 4 mm (5/32")
Driving shank (Hex)	6.35 mm (1/4")
No load speed	0 - 6,000 min ⁻¹
Dimensions (L x W x H)	279 x 65 x 207 mm (11 x 2-9/16 x 8-1/8")
Net weight	1.4 kg (3.1 lbs.)



570 W 0-6,000 RPM Drywall Screwdriver with LED Light

FS6200



Continuous rating	570W
Input	
Capacity	Drywall screw: 4 mm (5/32")
Driving shank (Hex)	6.35 mm (1/4")
No load speed	0 - 6,000 min ⁻¹
Dimensions (L x W x H)	269 x 65 x 207 mm (10-5/8 x 2-9/16 x 8-1/8")
Net weight	1.4 kg (3 lbs.)



Comparison List

Model No.	No load speed (min ⁻¹)	Mechanical 3-Speed / 2-Speed	Torque Setting	Max torque	Overall length	Net weight	BL motor
Cordless Driver Drill (DF001D: In-Line Cordless Screwdriver)							
DF003G	0 - 2,400 / 1,800 / 650	3-Speed	25 / 30 / 41	180 N-m	196 mm	2.8 - 4.0 kg (6.2 - 8.8 lbs.)	●
DF002G	0 - 2,200 / 600	2-Speed	21	70 N-m	164 mm	1.9 - 2.5 kg (4.2 - 5.5 lbs.)	●
DDF486	0 - 2,100 / 550	2-Speed	21	141 N-m	179 mm	2.3 - 2.6 kg (5.1 - 5.7 lbs.)	●
DDF489	0 - 1,800 / 550	2-Speed	21	110 N-m	174 mm	1.8 - 2.5 kg (4.0 - 5.5 lbs.)	●
DDF484	0 - 2,000 / 500	2-Speed	21	65 N-m	162 or 172 mm	1.5 - 2.2 kg (3.3 - 4.9 lbs)	●
DDF490	0 - 1,900 / 500	2-Speed	20	65 N-m	167 mm	1.4 - 1.7 kg (3.1 - 3.7 lbs.)	●
DDF485	0 - 1,900 / 500	2-Speed	21	65 N-m	169 mm	1.4 - 1.7 kg (3.1 - 3.8 lbs.)	●
DDF487	0 - 1,700 / 500	2-Speed	20	40 N-m	150 mm	1.3 - 1.6 kg (2.9 - 3.5 lbs.)	●
DDF458	0 - 2,000 / 400	2-Speed	21	110 N-m	225 mm	2.1 - 2.5 kg (4.7 - 5.4 lbs)	-
DDF451	0 - 1,700 / 600 / 300	3-Speed	16	63 N-m	238 mm	2.3 - 2.6 kg (5.0 - 5.7 lbs)	-
DDF482	0 - 1,900 / 600	2-Speed	21	64 N-m	185 mm	1.5 - 1.8 kg (3.2 - 4.0 lbs)	-
DDF453	0 - 1,300 / 400	2-Speed	16	48 N-m	222 mm	1.7 - 2.0 kg (3.7 - 4.4 lbs)	-
DDF083	0 - 1,700 / 500	2-Speed	20	40 N-m	124 mm	1.1 - 1.4 kg (2.4 - 3.0 lbs)	●
DF332D	0 - 1,500 / 450	2-Speed	20	38 N-m	154 mm	1 - 1.2 kg (2.3 - 2.6 lbs.)	●
DF032D	0 - 1,500 / 450	2-Speed	20	38 N-m	124 mm	0.88 - 1 kg (1.9 - 2.3 lbs.)	●
DF333D	0 - 1,700 / 450	2-Speed	20	34 N-m	179 mm	1.1 - 1.2 kg (2.4 - 2.7 lbs.)	-
DF033D	0 - 1,700 / 450	2-Speed	20	34 N-m	149 mm	0.9 - 1.1 kg (2.1 - 2.4 lbs.)	-
DF030D	0 - 1,300 / 350	2-Speed	18	28 N-m	157 mm	0.88 kg (1.9 lbs.)	-
DF330D	0 - 1,300 / 350	2-Speed	18	28 N-m	189 mm	1 kg (2.2 lbs.)	-
DF012D	650 / 200	2-Speed	21	11 N-m	218 mm	0.53 kg (1.2 lbs.)	-
DF001D	220	-	-	9 N-m	287 mm	0.36 kg (0.79 lbs.)	-
DF347D	0 - 1,400 / 400	2-Speed	16	34 N-m	198 mm	1.4 kg (3.2 lbs.)	-
Cordless Hammer Driver Drill							
HP003G	0 - 2,400 / 1,800 / 650	3-Speed	25 / 30 / 41	180 N-m	197 mm	2.8 - 4.0 kg (6.2 - 8.8 lbs.)	●
HP002G	0 - 2,200 / 600	2-Speed	21	70 N-m	174 mm	2.0 - 2.6 kg (4.4 - 5.7 lbs.)	●
DHP486	0 - 2,100 / 550	2-Speed	21	141 N-m	178 mm	2.7 kg (6.0 lbs.)	●
DHP489	0 - 1,800 / 550	2-Speed	21	110 N-m	175 mm	1.8 - 2.5 kg (4.0 - 5.5 lbs.)	●
DHP484	0 - 2,000 / 500	2-Speed	21	65 N-m	172 or 182 mm	1.6 - 2.2 kg (3.5 - 4.9 lbs.)	●
DHP490	0 - 1,900 / 500	2-Speed	20	65 N-m	172 mm	1.4 - 1.7 kg (3.1 - 3.7 lbs.)	●
DHP485	0 - 1,900 / 500	2-Speed	21	60 N-m	182 mm	1.5 - 1.8 kg (3.3 - 4.0 lbs.)	●
DHP487	0 - 1,700 / 500	2-Speed	20	40 N-m	164 mm	1.4 - 1.7 kg (3.1 - 3.7 lbs.)	●
DHP458	0 - 2,000 / 400	2-Speed	21	110 N-m	225 mm	2.2 - 2.6 kg (4.9 - 5.7 lbs)	-
DHP451	0 - 1,700 / 600 / 300	3-Speed	16	63 N-m	250 mm	2.5 - 2.9 kg (5.6 - 6.3 lbs)	-
DHP482	0 - 1,900 / 600	2-Speed	21	64 N-m	198 mm	1.5 - 1.8 kg (3.4 - 4.1 lbs)	-
DHP453	0 - 1,300 / 400	2-Speed	16	48 N-m	240 mm	1.7 - 2.0 kg (3.6 - 4.4 lbs)	-
HP333D	0 - 1,700 / 450	2-Speed	20	34 N-m	193 mm	1.1 - 1.3 kg (2.4 - 2.9 lbs.)	-
HP332D	0 - 1,500 / 450	2-Speed	20	38 N-m	168 mm	1.1 - 1.3 kg (2.4 - 2.8 lbs.)	●
HP330D	0 - 1,500 / 400	2-Speed	18	28 N-m	201 mm	1.1 kg (2.3 lbs.)	-
HP347D	0 - 1,400 / 400	2-Speed	16	34 N-m	216 mm	1.4 kg (3.1 lbs.)	-

Comparison List

Model No.	No load speed (min ⁻¹)	Electronic Speed	Max. fastening torque	Overall length	Net weight	BL motor
-----------	------------------------------------	------------------	-----------------------	----------------	------------	----------

Cordless Impact Driver

TD004G	0 - 3,900 / 3,000 / 2,100 / 1,200	4-Speed	230 N-m	136 mm	1.8 - 3.1 kg (4.0 - 6.8 lbs.)	●
TD002G	0 - 3,700 / 3,200 / 2,100 / 1,100	4-Speed	220 N-m	130 mm	1.7 - 2.9 kg (3.7 - 6.4 lbs.)	●
TD001G	0 - 3,700 / 3,200 / 2,100 / 1,100	4-Speed	220 N-m	120 mm	1.7 kg (3.7 lbs.)	●
TD003G	0 - 3,700 / 3,200 / 2,100 / 1,100	4-Speed	210 N-m	121 mm	1.7 - 2.9 kg (3.7 - 6.4 lbs.)	●
DTD173	0 - 3,600 / 3,200 / 2,100 / 1,100	4-Speed	180 N-m	111 mm	1.5 kg (3.3 lbs.)	●
DTD201	0 - 3,700 / 3,200 / 2,100 / 1,100	4-Speed	210 N-m	121 mm	1.3 - 2.3 kg (2.9 - 5.1 lbs.)	●
DTD153	0 - 3,400	-	170 N-m	126 mm	1.3 - 1.6 kg (2.9- 3.5 lbs)	●
DTD152	0 - 2,900	-	165 N-m	137 mm	1.3 - 1.6 kg (2.8 - 3.5 lbs)	-
DTD156	0 - 2,500	-	155 N-m	143 mm	1.3 - 1.6 kg (2.9 - 3.6 lbs.)	-
DTD157	0 - 3,000 / 1,300	2-Speed	140 N-m	133 mm	1.2 - 1.5 kg (2.6 - 3.3 lbs)	●
TD111D	0 - 3,000 / 1,300	2-Speed	135 N-m	135 mm	0.97 - 1.1 kg (2.1 - 2.5 lbs.)	●
TD110D	0 - 2,600	-	110 N-m	153 mm	1 - 1.2 kg (2.3 - 2.6 lbs.)	-
TD090D	0 - 2,400	-	90 N-m	155 mm	0.92 kg (2 lbs.)	-
TD022D	0 - 2,450	-	25 N-m	227 mm	0.56 kg (1.2 lbs.)	-
TD127D	0 - 2,300	-	140 N-m	173 mm	1.5 kg (3.2 lbs.)	-

Cordless 4 Mode Impact Driver (Impact-driver mode)

DTP141	0 - 2,700 / 2,200 / 1,300	3-Speed	150 N-m	171 mm	1.5 - 1.9 kg (3.4 - 4.1 lbs)	●
--------	---------------------------	---------	---------	--------	------------------------------	---

Cordless Oil-Pulse Driver

DTS141	0 - 3,200 / 2,000 / 1,200	3-Speed	40 N-m	136 mm	1.3 - 1.6 kg (2.8 - 3.5 lbs)	●
--------	---------------------------	---------	--------	--------	------------------------------	---

Model No.	Square drive	Max Fastening Torque	No load speed (min ⁻¹)	Overall length	Net weight	BL motor
-----------	--------------	----------------------	------------------------------------	----------------	------------	----------

Cordless Impact Wrench

TW010G	1" (25.4 mm)	3,150 N-m	0 - 1,200 / 850 / 700 / 600	570 mm	12.0 - 12.9 kg (26.5 - 28.4 lbs.)	●
TW001G	3/4" (19 mm)	1,800 N-m	0 - 1,800 / 1,400 / 1,150 / 950	217 mm	3.9 - 4.2 kg (8.6 - 9.3 lbs.)	●
TW002G	1/2" (12.7mm)	1,700 N-m	0 - 1,800 / 1,000 / 900 / 850	213 mm	3.9 - 5.1 kg (8.6 - 11.2 lbs.)	●
TW011G	3/4" (19 mm)	1,500 N-m	0 - 1,800 / 1,100 / 700 / 500	329 mm	4.3 - 5.5 kg (9.5 - 12.1 lbs.)	●
TW003G	1/2" (12.7mm)	1,360 N-m	0 - 1,800 / 1,200 / 1,000 / 800	213 mm	3.8 - 5.0 kg (8.4 - 11.0 lbs.)	●
TW007G	1/2" (12.7mm)	760 N-m	0 - 2,300 / 1,900 / 1,200 / 600	170 mm	2.7 - 3.3 kg (6.0 - 7.3 lbs.)	●
TW008G	1/2" (12.7mm)	760 N-m	0 - 2,300 / 1,900 / 1,200 / 600	170 mm	2.7 - 3.3 kg (6.0 - 7.3 lbs.)	●
TW004G	1/2" (12.7mm)	350 N-m	0 - 3,200 / 2,600 / 1,800 / 1,000	144 mm	1.9 - 2.2 kg (4.2 - 4.9 lbs.)	●
TW005G	1/2" (12.7mm)	350 N-m	0 - 3,200 / 2,600 / 1,800 / 1,000	144 mm	1.9 - 2.2 kg (4.2 - 4.9 lbs.)	●
DTW1005	3/4" (19mm)	1,360 N-m	0 - 1,800 / 1,000 / 900 / 800	339 mm	3.9 - 4.2 kg (8.6 - 9.3 lbs.)	●
DTW1001	3/4" (19mm)	1,250 N-m	0 - 1,800 / 1,000 / 900	229 mm	3.7 kg (8.2 lbs.)	●
DTW1002	1/2" (12.7mm)	1,200 N-m	0 - 1,800 / 1,000 / 900	229 mm	3.6 kg (7.9 lbs.)	●
DTW1004	1/2" (12.7mm)	1,050 N-m	0 - 2,000 / 1,000 / 900	223 mm	3.4 kg (7.5 lbs.)	●
DTW800	7/16" (11.1mm) Hex.	800 N-m	0 - 1,800 / 1,000 / 900	229 mm	3.4 - 3.7 kg (7.5 - 8.2 lbs)	●
DTW700	1/2" (12.7mm)	700 N-m	0 - 2,200 / 1,900 / 1,200 / 500	170 mm	2.3 - 2.7 kg (5.1 - 6.0 lbs)	●
DTW701	1/2" (12.7mm)	700 N-m	0 - 2,200 / 1,900 / 1,200 / 500	170 mm	2.3 - 2.7 kg (5.1 - 6.0 lbs)	●
DTW450	1/2" (12.7mm)	440 N-m	1,600	266 mm	3.1 - 3.4 kg (6.9 - 7.6 lbs)	-
DTW300	1/2" (12.7mm)	330 N-m	0 - 3,200 / 2,600 / 1,800 / 1,000	144 mm	1.8 kg (4.0 lbs.)	●
DTW301	1/2" (12.7mm)	330 N-m	0 - 3,200 / 2,600 / 1,800 / 1,000	144 mm	1.8 kg (4.0 lbs.)	●
DTW302	3/8" (9.5 mm)	300 N-m	0 - 3,200 / 2,600 / 1,800 / 1,000	138 mm	1.8 kg (4.0 lbs.)	●
DTW251	1/2" (12.7mm)	230 N-m	0 - 2,100	165 mm	1.5 - 1.8 kg (3.2 - 3.9 lbs)	-
DTW253	3/8" (9.5mm)	210 N-m	0 - 2,100	155 mm	1.3 - 1.6 kg (2.8 - 3.6 lbs)	-
DTW181	1/2" (12.7mm)	210 N-m	0 - 2,400 / 1,300	151 mm	1.2 - 1.5 kg (2.7 - 3.4 lbs.)	●
DTW190	1/2" (12.7mm)	190 N-m	0 - 2,300	176 mm	1.4 - 1.8 kg (3.2 - 3.9 lbs)	-
DTW180	3/8" (9.5mm)	180 N-m	0 - 2,400 / 1,300	144 mm	1.2 - 1.5 kg (2.7 - 3.4 lbs.)	●
TW161D	1/2" (12.7 mm)	165 N-m	0 - 2,400 / 1,300	150 mm	1.1 - 1.2 kg (2.4 - 2.7 lbs.)	●
TW160D	3/8" (9.5 mm)	160 N-m	0 - 2,400 / 1,300	144 mm	1.0 - 1.2 kg (2.2 - 2.6 lbs.)	●
TW141D	1/2" (12.7 mm)	145 N-m	0 - 2,600	168 mm	1.1 - 1.2 kg (2.4 - 2.7 lbs.)	-
TW140D	3/8" (9.5 mm)	140 N-m	0 - 2,600	161 mm	1.0 - 1.2 kg (2.3 - 2.7 lbs.)	-
TW060D	1/4" (6.35 mm)	60 N-m	0 - 2,600	161 mm	1.0 - 1.2 kg (2.2 - 2.6 lbs.)	-
TW100D	3/8" (9.5 mm)	110 N-m	0 - 2,300	163 mm	0.95 kg (2.1 lbs.)	-
TW202D	1/2" (12.7 mm)	200 N-m	0 - 2,300	176 mm	1.5 kg (3.3 lbs.)	-

Cordless Tools for Industry



Screwdriver, Angle Screwdriver

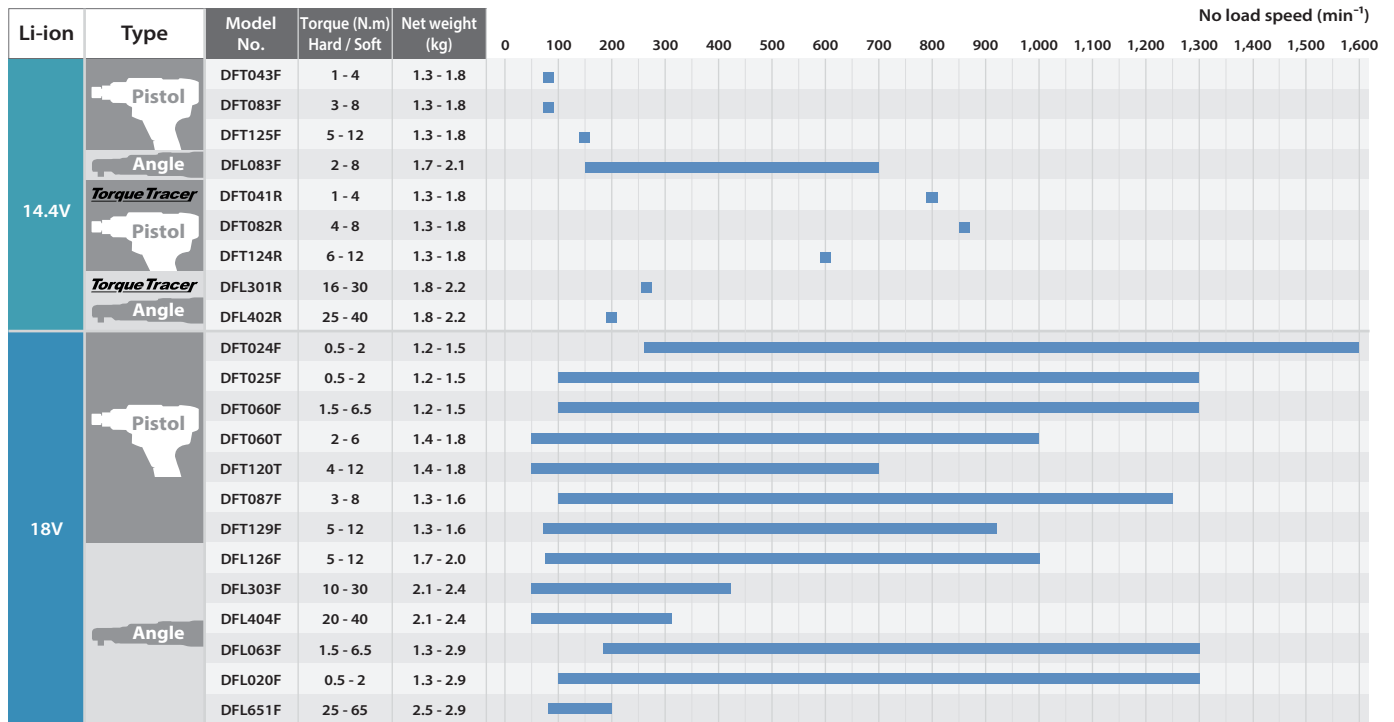

Impact Driver, Impact Wrench

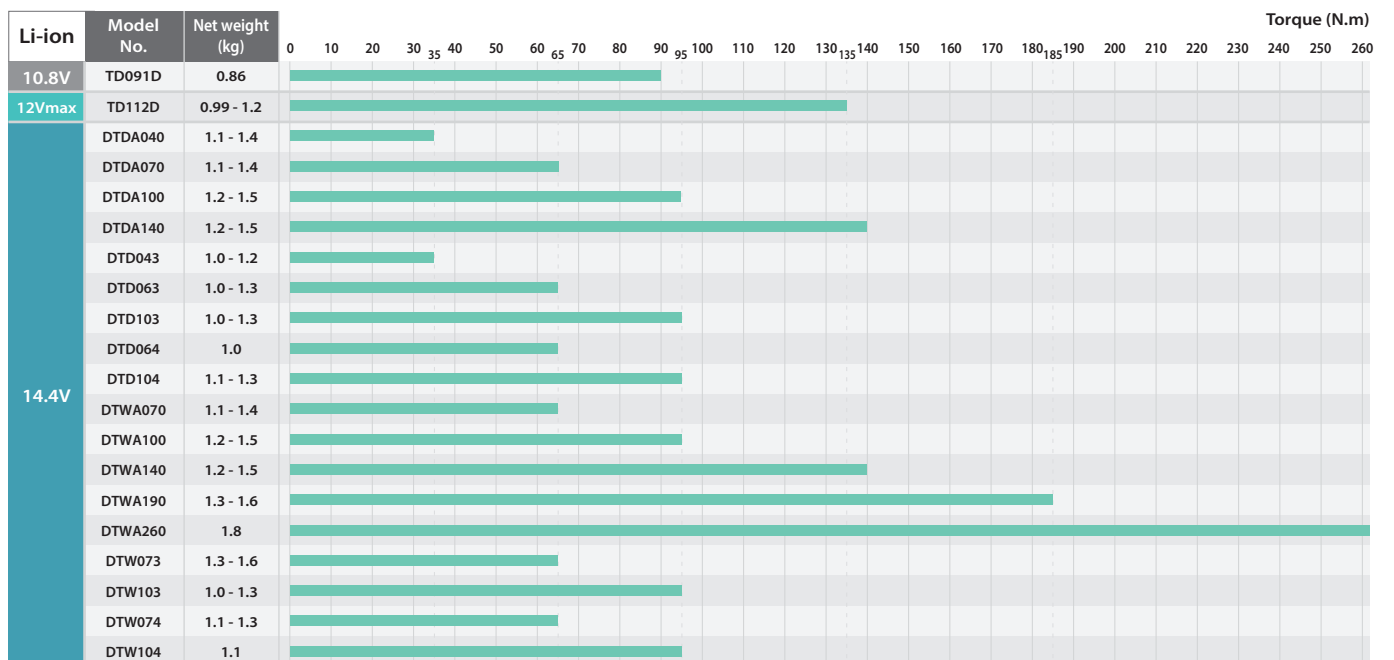

18V LXT BL Brushless Programmable Cordless Screwdriver



	DFT060T	DFT120T
Driving shank (Hex)	6.35 mm (1/4")	6.35 mm (1/4")
No load speed	50 - 1,000 min ⁻¹	50 - 700 min ⁻¹
Fastening torque	Hard / Soft: 2 - 6 / 2 - 6 N-m (18 - 53 / 18 - 53 in.lbs.)	Hard / Soft: 4-12 / 4-12 N-m (35-106 / 35-106 in.lbs.)
Dimensions (L x W x H)	w/ BL1830B / BL1840B / BL1850B / BL1860B: 206 x 75 x 263 mm (8-1/8 x 2-15/16 x 10-3/8")	w/ BL1830B / BL1840B / BL1850B / BL1860B: 206 x 75 x 263 mm (8-1/8 x 2-15/16 x 10-3/8")
Net weight	1.4 - 1.8 kg (3.1 - 4.0 lbs.)	1.4 - 1.8 kg (3.1 - 4.0 lbs.)

18V LXT BL Brushless Programmable Cordless Screwdriver



	DFT024F	DFT025F	DFT060F
Driving shank (Hex)	6.35 mm (1/4")	6.35 mm (1/4")	6.35 mm (1/4")
No load speed	260 - 1,600 min ⁻¹	100 - 1,300 min ⁻¹	100 - 1,300 min ⁻¹
Fastening torque	Hard / Soft: 0.5 - 2 / 0.5 - 2 N-m (4 - 18 / 4 - 18 in.lbs.)	Hard / Soft: 0.5 - 2 / 0.5 - 2 N-m (4 - 18 / 4 - 18 in.lbs.)	Hard / Soft: 1.5 - 6.5 / 1.5 - 6.5 N-m (10 - 60 / 10 - 60 in.lbs.)
Dimensions (L x W x H)	w/ BL1830B / BL1840B / BL1850B / BL1860B: 161 x 75 x 258 mm (6-3/8 x 2-15/16 x 10-1/8")	w/ BL1830B / BL1840B / BL1850B / BL1860B: 161 x 75 x 258 mm (6-3/8 x 2-15/16 x 10-1/8")	w/ BL1830B / BL1840B / BL1850B / BL1860B: 161 x 75 x 258 mm (6-3/8 x 2-15/16 x 10-1/8")
Net weight	1.2 - 1.5 kg (2.6 - 3.3 lbs.)	1.2 - 1.5 kg (2.6 - 3.3 lbs.)	1.2 - 1.5 kg (2.6 - 3.3 lbs.)

18V LXT BL Programmable Cordless Screwdriver



	DFT087F	DFT129F
Driving shank (Hex)	6.35 mm (1/4")	6.35 mm (1/4")
No load speed	100 - 1,250 min ⁻¹	70 - 900 min ⁻¹
Fastening torque	Hard / Soft: 3 - 8 / 3 - 8 N-m (27 - 71 / 27 - 71 in.lbs.)	Hard / Soft: 5 - 12 / 5 - 12 N-m (44 - 106 / 44 - 106 in.lbs.)
Dimensions (L x W x H)	For products with specifications not compatible with HERUTU module, w/ BL1830B / BL1840B / BL1850B / BL1860B: 179 x 75 x 258 mm (7 x 2-15/16 x 10-1/8")	For products with specifications not compatible with HERUTU module, w/ BL1830B / BL1840B / BL1850B / BL1860B: 179 x 75 x 258 mm (7 x 2-15/16 x 10-1/8")
Net weight	1.3 - 1.6 kg (2.9 - 3.5 lbs.)	1.3 - 1.6 kg (2.9 - 3.5 lbs.)

14.4V LXT Li-Ion Cordless Screwdriver



	DFT043F	DFT083F	DFT125F
Driving shank (Hex)	6.35 mm (1/4")	6.35 mm (1/4")	6.35 mm (1/4")
No load speed	80 min ⁻¹	80 min ⁻¹	150 min ⁻¹
Fastening torque	Hard / Soft: 1-4 / 1-4 N-m (8.9-35 / 8.9-35 in.lbs.)	Hard / Soft: 3-8 / 3-8 N-m (27-71 / 27-71 in.lbs.)	Hard / Soft: 5-12 / 5-12 N-m (44-106 / 44-106 in.lbs.)
Dimensions (L x W x H)	200 x 72 x 255 mm (7-7/8 x 2-13/16 x 10")	200 x 72 x 255 mm (7-7/8 x 2-13/16 x 10")	200 x 72 x 255 mm (7-7/8 x 2-13/16 x 10")
Net weight	1.3 - 1.8 kg (2.9 - 4 lbs.)	1.3 - 1.8 kg (2.9 - 4 lbs.)	1.3 - 1.8 kg (2.9 - 4 lbs.)

18V LXT BL Brushless Cordless Angle Screwdriver



	DFL126F	DFL303F	DFL404F
Driving shank (Square)	9.5 mm (3/8")	9.5 mm (3/8")	9.5 mm (3/8")
No load speed	75 - 1,000 min ⁻¹	50 - 420 min ⁻¹	95 - 310 min ⁻¹
Max rotation speed with guaranteed torque accuracy	600 min ⁻¹	230 min ⁻¹	220 min ⁻¹
Fastening torque	Hard / Soft: 5 - 12 / 5 - 12 N-m (40 - 110 / 40 - 110 in.lbs.)	Hard / Soft: 10 - 30 / 10 - 30 N-m (89 - 266 / 89 - 266 in.lbs.)	Hard / Soft: 20 - 40 / 20 - 40 N-m (180 - 350 / 180 - 350 in.lbs.)
Dimensions (L x W x H)	408 - 426 x 81 x 116 mm (16 - 16-3/4 x 3-3/16 x 4-9/16")	456 - 472 x 81 x 116 mm (18 - 18-5/8 x 3-3/16 x 4-9/16")	456 - 472 x 81 x 116 mm (18 - 18-5/8 x 3-3/16 x 4-9/16")
Net weight	1.7 - 2.0 kg (3.7 - 4.4 lbs.)	2.1 - 2.4 kg (4.6 - 5.3 lbs.)	2.1 - 2.4 kg (4.6 - 5.3 lbs.)

14.4V LXT BL Brushless Cordless 8 N-m (71 in.lbs.) Angle Screwdriver



	DFL083F
Driving shank (Square)	9.5 mm (3/8")
No load speed	150-700 min ⁻¹
Fastening torque	Hard / Soft: 2-8 / 2-8 N-m (18-71 / 18-71 in.lbs.)
Dimensions (L x W x H)	w/ BL1430(B) / BL1440 / BL1450 / BL1460B: 481 x 74 x 98 mm (19 x 2-15/16 x 3-7/8")
Net weight	1.7 - 2.1 kg (3.8 - 4.7 lbs.)

18V LXT BL Brushless Cordless Angle Screwdriver



	DFL020F	DFL063F	DFL651F
Driving shank (Square)	9.5 mm (3/8")	9.5 mm (3/8")	9.5, 12.7 mm (3/8, 1/2")
No load speed	100 - 1,300 min ⁻¹	100 - 1,300 min ⁻¹	80 - 200 min ⁻¹
Max rotation speed with guaranteed torque accuracy	600 min ⁻¹	600 min ⁻¹	-
Fastening torque	Hard / Soft: 0.5 - 2 / 0.5 - 2 N-m (4 - 18 / 4 - 18 in.lbs.)	Hard / Soft: 1.5 - 6.5 / 1.5 - 6.5 N-m (13 - 58 / 13 - 58 in.lbs.)	Hard / Soft: 25-65 / 25-65 N-m (220-580 / 220-580 in.lbs.)
Dimensions (L x W x H)	380 - 397 x 81 x 116 mm (15 - 15-5/8 x 3-3/16 x 4-9/16")	380 - 397 x 81 x 116 mm (15 - 15-5/8 x 3-3/16 x 4-9/16")	600 x 75 x 116 mm (23-5/8 x 2-15/16 x 4-9/16")
Net weight	1.3 - 2.9 kg (1.6 - 3.5 lbs.)	1.3 - 2.9 kg (1.7 - 3.8 lbs.)	2.5-2.9 kg (5.5-6.5 lbs.)

Cordless Tools for Industry

14.4V LXT BL Brushless Cordless Screwdriver, Torque Tracer

14.4V



LXT BL MOTOR Torque Tracer



	DFT041R	DFT082R	DFT124R
Driving shank (Hex)	6.35 mm (1/4")	6.35 mm (1/4")	6.35 mm (1/4")
No load speed	800 min ⁻¹	860 min ⁻¹	600 min ⁻¹
Fastening torque	Hard / Soft: 1-4 / 1-4 N-m (8.9-35 / 8.9-35 in.lbs.)	Hard / Soft: 4-8 / 4-8 N-m (35-71 / 35-71 in.lbs.)	Hard / Soft: 6-12 / 6-12 N-m (53-106 / 53-106 in.lbs.)
Dimensions (L x W x H)	191 x 72 x 266 mm (7-1/2 x 2-13/16 x 10-1/2")	191 x 72 x 266 mm (7-1/2 x 2-13/16 x 10-1/2")	191 x 72 x 266 mm (7-1/2 x 2-13/16 x 10-1/2")
Net weight	1.3 - 1.8 kg (2.9 - 4 lbs.)	1.3 - 1.8 kg (2.9 - 4 lbs.)	1.3 - 1.8 kg (2.9 - 4 lbs.)

14.4V LXT BL Brushless Cordless Angle Screwdriver, Torque Tracer

14.4V



LXT BL MOTOR Torque Tracer



	DFL301R	DFL402R
Driving shank (Square)	9.5 mm (3/8")	9.5 mm (3/8")
No load speed	260 min ⁻¹	200 min ⁻¹
Fastening torque	Hard / Soft: 16-30 / 16-30 N-m (142-266 / 142-266 in.lbs.)	Hard / Soft: 25-40 / 25-40 N-m (221-354 / 221-354 in.lbs.)
Dimensions (L x W x H)	477 x 72 x 98 mm (18-3/4 x 2-13/16 x 3-7/8")	477 x 72 x 98 mm (18-3/4 x 2-13/16 x 3-7/8")
Net weight	1.8-2.2 kg (4-4.8 lbs.)	1.8-2.2 kg (4-4.8 lbs.)

14.4V LXT BL Brushless Cordless Impact Driver

14.4V



LXT BL MOTOR



	DTDA040	DTDA070	DTDA100	DTDA140
Capacity	Standard bolt: M5 - M10 (3/16 - 3/8") High strength bolt: M5 - M8 (3/16 - 5/16")	Standard bolt: M5 - M12 (3/16 - 1/2") High strength bolt: M5 - M10 (3/16 - 3/8")	Standard bolt: M5 - M12 (3/16 - 1/2") High strength bolt: M5 - M10 (3/16 - 3/8")	Standard bolt: M6 - M16 (1/4 - 5/8") High strength bolt: M6 - M12 (1/4 - 1/2")
Max fastening torque	35 N-m (310 in.lbs.)	65 N-m (575 in.lbs.)	95 N-m (840 in.lbs.)	140 N-m (1,240 in.lbs.)
No load speed	0 - 2,400 min ⁻¹	0 - 2,500 min ⁻¹	0 - 2,700 min ⁻¹	0 - 2,700 min ⁻¹
Impacts per minute	0 - 3,700 min ⁻¹	0 - 3,700 min ⁻¹	0 - 3,300 min ⁻¹	0 - 3,300 min ⁻¹
Dimensions (L x W x H)	w/ BL1430(B) / BL1440 / BL1450 / BL1460B: 139 x 74 x 256 mm (5-1/2 x 2-15/16 x 10-1/8")	w/ BL1430(B) / BL1440 / BL1450 / BL1460B: 139 x 74 x 256 mm (5-1/2 x 2-15/16 x 10-1/8")	w/ BL1430(B) / BL1440 / BL1450 / BL1460B: 146 x 74 x 256 mm (5-3/4 x 2-15/16 x 10-1/8")	w/ BL1430(B) / BL1440 / BL1450 / BL1460B: 146 x 74 x 256 mm (5-3/4 x 2-15/16 x 10-1/8")
Net weight	1.1 - 1.4 kg (2.4 - 3.1 lbs.)	1.1 - 1.4 kg (2.4 - 3.1 lbs.)	1.2 - 1.5 kg (2.7 - 3.3 lbs.)	1.2 - 1.5 kg (2.7 - 3.3 lbs.)

14.4V LXT Li-Ion Cordless Impact Driver

14.4V



LXT



	DTD104	DTD064
Capacity	Machine screw: M4 - M8 (5/32 - 5/16") Standard bolt: M5 - M12 (3/16 - 1/2") High strength bolt: M5 - M10 (3/16 - 3/8")	Machine screw: M4 - M8 (5/32 - 5/16") Standard bolt: M5 - M12 (3/16 - 1/2") High strength bolt: M5 - M10 (3/16 - 3/8")
Max fastening torque	95 N-m (841 in.lbs.)	35 N-m (310 in.lbs.)
No load speed	0 - 2,700 min ⁻¹	0 - 2,500 min ⁻¹
Impacts per minute	0 - 3,500 min ⁻¹	0 - 3,500 min ⁻¹
Dimensions (L x W x H)	144 x 74 x 216 mm (5-5/8 x 2-15/16 x 8-1/2")	144 x 74 x 216 mm (5-5/8 x 2-15/16 x 8-1/2")
Net weight	1.1 - 1.3 kg (2.3 - 2.9 lbs.)	1 kg (2.3 lbs.)

9.6V Ni-MH Cordless 40 N-m (354 in.lbs.) Impact Driver

9.6V



	BTD040
Capacity	Machine screw: M4 - M8 (5/32 - 5/16") Standard bolt: M5 - M10 (3/16 - 3/8") High strength bolt: M5 - M8 (3/16 - 5/16")
Max fastening torque	40 N-m (354 in.lbs.)
No load speed	0 - 2,500 min ⁻¹
Impacts per minute	0 - 3,500 min ⁻¹
Overall length	164 mm (6-7/16")
Net weight	1.1 - 1.3 kg (2.4 - 2.8 lbs.)

14.4V LXT Li-Ion Cordless Impact Driver

14.4V



LXT



	DTD103	DTD063	DTD043
Capacity	Machine screw: M4 - M8 (5/32 - 5/16") Standard bolt: M5 - M12 (3/16 - 1/2") High strength bolt: M5 - M10 (3/16 - 3/8")	Machine screw: M4 - M8 (5/32 - 5/16") Standard bolt: M5 - M12 (3/16 - 1/2") High strength bolt: M5 - M10 (3/16 - 3/8")	Machine screw: M4 - M8 (5/32 - 5/16") Standard bolt: M5 - M10 (3/16 - 3/8") High strength bolt: M5 - M6 (3/16 - 1/4")
Max fastening torque	95 N-m (841 in.lbs.)	65 N-m (575 in.lbs.)	35 N-m (310 in.lbs.)
No load speed	0 - 2,700 min ⁻¹	0 - 2,500 min ⁻¹	0 - 2,300 min ⁻¹
Impacts per minute	0 - 3,500 min ⁻¹	0 - 3,500 min ⁻¹	0 - 3,500 min ⁻¹
Dimensions (L x W x H)	144 x 74 x 216 mm (5-5/8 x 2-15/16 x 8-1/2")	144 x 74 x 216 mm (5-5/8 x 2-15/16 x 8-1/2")	144 x 74 x 216 mm (5-5/8 x 2-15/16 x 8-1/2")
Net weight	1 - 1.3 kg (2.3 - 2.8 lbs.)	1 - 1.3 kg (2.3 - 2.8 lbs.)	1 - 1.2 kg (2.2 - 2.7 lbs.)

12Vmax CXT BL Brushless Cordless 135 N-m (1,200 in.lbs.) Impact Driver

12V max



CXT BL MOTOR



	TD112D
Capacity	Standard bolt: M5 - M14 (3/16 - 9/16") High strength bolt: M5 - M12 (3/16 - 1/2")
Max fastening torque	Hard / Soft: 135 N-m (1,200 in.lbs.) / 80 N-m (700 in.lbs.)
No load speed	Hard / Soft: 0 - 3,000 / 0 - 2,000 min ⁻¹
Impacts per minute	Hard / Soft: 0 - 3,900 / 0 - 3,300 min ⁻¹
Dimensions (L x W x H)	w/ BL1041B: 145 x 64 x 240 mm (5-3/4 x 2-1/2 x 9-1/2")
Net weight	0.99 - 1.2 kg (2.2 - 2.6 lbs.)

10.8V (12V max) Li-Ion Cordless 90 N-m (800 in.lbs.) Impact Driver

10.8V



TD091D	
Capacity	Machine screw: M4 - M8 (5/32 - 5/16") Standard bolt: M5 - M12 (3/16 - 1/2") High strength bolt: M5 - M10 (3/16 - 3/8") Coarse thread (in length): 22 - 90 mm (7/8 - 3-1/2")
Max fastening torque	90 N-m (800 in.lbs.)
No load speed	0 - 2,400 min ⁻¹
Impacts per minute	0 - 3,000 min ⁻¹
Dimensions (L x W x H)	134 x 54 x 200 mm (5-1/4 x 2-1/8 x 7-7/8")
Net weight	0.86 kg (1.9 lbs.)

18V LXT BL Brushless Cordless 12.7 mm (1/2") 260 N-m Impact Wrench

18V



DTWA260	
Square drive	12.7 mm (1/2")
Max fastening torque	260 N-m (190 ft.lbs.)
Capacity	Standard bolt: M14 - M20 (9/16 - 3/4") High strength bolt: M10 - M16 (3/8 - 5/8")
No load speed	0 - 2,800 min ⁻¹
Impacts per minute	0 - 3,400 min ⁻¹
Dimensions (L x W x H)	w/ BL1830B / BL1840B / BL1850B / BL1860B: 161 x 82 x 265 mm (6-3/8 x 3-1/4 x 10-3/8")
Net weight	1.8 kg (4.0 lbs.)

14.4V LXT BL Brushless Cordless Impact Wrench

14.4V



	DTWA070	DTWA100	DTWA140	DTWA190
Square drive	9.5 mm (3/8")	9.5 mm (3/8")	12.7 mm (1/2")	12.7 mm (1/2")
Max fastening torque	65 N-m (48 ft.lbs.)	95 N-m (70 ft.lbs.)	140 N-m (103 ft.lbs.)	185 N-m (136 ft.lbs.)
Capacity	Standard bolt: M5 - M12 (3/16 - 1/2") High strength bolt: M5 - M10 (3/16 - 3/8")	Standard bolt: M5 - M12 (3/16 - 1/2") High strength bolt: M5 - M10 (3/16 - 3/8")	Standard bolt: M6 - M16 (1/4 - 5/8") High strength bolt: M6 - M12 (1/4 - 1/2")	Standard bolt: M8 - M16 (5/16 - 5/8") High strength bolt: M8 - M14 (5/16 - 9/16")
No load speed	0 - 2,500 min ⁻¹	0 - 2,700 min ⁻¹	0 - 2,700 min ⁻¹	0 - 2,600 min ⁻¹
Impacts per minute	0 - 3,700 min ⁻¹	0 - 3,300 min ⁻¹	0 - 3,300 min ⁻¹	0 - 3,000 min ⁻¹
Dimensions (L x W x H)	w/ BL1430(B) / BL1440 / BL1450 / BL1460B: 144 x 74 x 256 mm (5-5/8 x 2-15/16 x 10-1/8")	w/ BL1430(B) / BL1440 / BL1450 / BL1460B: 151 x 74 x 256 mm (5-15/16 x 2-15/16 x 10-1/8")	w/ BL1430(B) / BL1440 / BL1450 / BL1460B: 158 x 74 x 256 mm (6-1/4 x 2-15/16 x 10-1/8")	w/ BL1430(B) / BL1440 / BL1450 / BL1460B: 158 x 74 x 256 mm (6-1/4 x 2-15/16 x 10-1/8")
Net weight	1.1 - 1.4 kg (2.4 - 3.1 lbs.)	1.2 - 1.5 kg (2.7 - 3.3 lbs.)	1.2 - 1.5 kg (2.7 - 3.3 lbs.)	1.3 - 1.6 kg (2.9 - 3.5 lbs.)

14.4V LXT BL Brushless Cordless 9.5 mm (3/8") Impact Wrench

14.4V



	DTW104	DTW074
Square drive	9.5 mm (3/8")	9.5 mm (3/8")
Max fastening torque	95 N-m (841 in.lbs.)	65 N-m (575 in.lbs.)
Capacity	Standard bolt: M5 - M12 (3/16 - 1/2") High strength bolt: M5 - M10 (3/16 - 3/8")	Standard bolt: M5 - M12 (3/16 - 1/2") High strength bolt: M5 - M10 (3/16 - 3/8")
No load speed	0 - 2,700 min ⁻¹	0 - 2,500 min ⁻¹
Impacts per minute	0 - 3,500 min ⁻¹	0 - 3,500 min ⁻¹
Dimensions (L x W x H)	w/ BL1430(B) / BL1440 / BL1450 / BL1460B: 144 x 74 x 234 mm (5-5/8 x 2-15/16 x 9-1/4")	144 x 74 x 216 mm (5-5/8 x 2-15/16 x 8-1/2")
Net weight	1.1 kg (2.4 lbs.)	1.1 - 1.3 kg (2.3 - 2.9 lbs.)

14.4V LXT Li-Ion Cordless 3/8" (9.5 mm) Impact Wrench

14.4V



	DTW103	DTW073
Max fastening torque	95 N-m (841 in.lbs.)	65 N-m (575 in.lbs.)
Capacity	Standard bolt: M5 - M12 (3/16 - 1/2") High strength bolt: M5 - M10 (3/16 - 3/8")	Standard bolt: M5 - M12 (3/16 - 1/2") High strength bolt: M5 - M10 (3/16 - 3/8")
No load speed	0 - 2,700 min ⁻¹	0 - 2,500 min ⁻¹
Impacts per minute	0 - 3,500 min ⁻¹	0 - 3,500 min ⁻¹
Dimensions (L x W x H)	144 x 74 x 216 mm (5-5/8 x 2-15/16 x 8-1/2")	144 x 74 x 216 mm (5-5/8 x 2-15/16 x 8-1/2")
Net weight	1 - 1.3 kg (2.3 - 2.8 lbs.)	1.3 - 1.6 kg (2.9 - 3.5 lbs.)

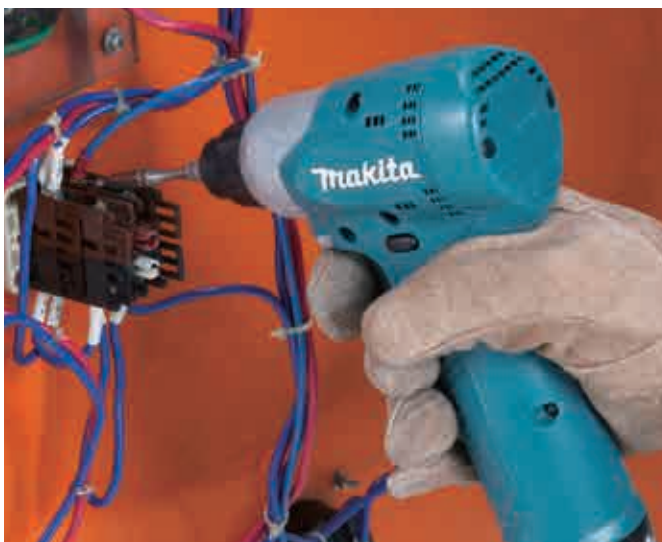

Stirring

Icon



Double Insulation



Variable Speed



Anti-restart function



Mechanical 2-Speed



Electronic 2-Speed



Constant Speed



Soft Start



Carrying Case

40Vmax XGT Cordless Concrete Vibrator

VR001G

40V max



Vibrations per minute	Power mode: 15,500 min ⁻¹ Normal mode: 12,000 min ⁻¹
Work amount on a full battery charge	w/ 28mm - 0.8m shaft, w/ BL4040, Power mode: 45 min w/ 28mm - 0.8m shaft, w/ BL4040, Normal mode: 60 min w/o Flexible shaft, Battery case L set: 296 x 112 x 299 mm (11-5/8 x 4-3/8 x 11-3/4")
Dimensions (L x W x H)	w/o Flexible shaft, Battery case L set: 296 x 112 x 299 mm (11-5/8 x 4-3/8 x 11-3/4")
Net weight	4.8 - 7.8 kg (10.6 - 17.2 lbs.)

XGT BL MOTOR XPT



40Vmax XGT Cordless 32 mm (1-1/4") Concrete Vibrator

VR003G

40V max



Vibrator diameter	32 mm (1-1/4")
Flexible shaft length	1.2, 1.7, 2.4 m (3.9, 5.6, 7.9 ft)
Vibrations per minute	Power mode: 15,500 min ⁻¹ Normal mode: 12,000 min ⁻¹
Work amount on a full battery charge	w/ 28mm - 0.8m shaft, w/ BL4040, Power mode: 45 min w/ 28mm - 0.8m shaft, w/ BL4040, Normal mode: 60 min w/o Flexible shaft, Battery case L set: 296 x 112 x 299 mm (11-5/8 x 4-3/8 x 11-3/4")
Dimensions (L x W x H)	w/o Flexible shaft, Battery case L set: 296 x 112 x 299 mm (11-5/8 x 4-3/8 x 11-3/4")
Net weight	4.8 - 7.8 kg (10.6 - 17.2 lbs.)

XGT BL MOTOR XPT



40Vmax XGT Cordless 38 mm (1-1/2") Concrete Vibrator

VR004G

40V max



Vibrator diameter	38 mm (1-1/2")
Flexible shaft length	1.2, 2.4 m (3.9, 7.9 ft)
Vibrations per minute	Power mode: 15,500 min ⁻¹ Normal mode: 12,000 min ⁻¹
Work amount on a full battery charge	w/ 28mm - 0.8m shaft, w/ BL4040, Power mode: 45 min w/ 28mm - 0.8m shaft, w/ BL4040, Normal mode: 60 min w/o Flexible shaft, Battery case L set: 296 x 112 x 299 mm (11-5/8 x 4-3/8 x 11-3/4")
Dimensions (L x W x H)	w/o Flexible shaft, Battery case L set: 296 x 112 x 299 mm (11-5/8 x 4-3/8 x 11-3/4")
Net weight	4.8 - 7.8 kg (10.6 - 17.2 lbs.)

XGT BL MOTOR XPT



18V LXT Li-Ion Cordless 2.4 m (8.0 ft) 25 mm (1") Concrete Vibrator

DVR850

18V



Vibrator diameter	25 mm (1")
Flexible shaft length	2,400 mm (8 ft)
Vibrations per minute	12,500 min ⁻¹
Dimensions (L x W x H)	2,683 x 93 x 250 mm (105-1/2 x 3-5/8 x 9-7/8")
Net weight	4.5 - 5.5 kg (9.9 - 12 lbs.)

LXT

18V LXT Li-Ion Cordless 1.2 m (4.0 ft) 25 mm (1") Concrete Vibrator

DVR450

18V



Vibrator diameter	25 mm (1")
Flexible shaft length	1,200 mm (4.0 ft)
Vibrations per minute	13,000 min ⁻¹
Dimensions (L x W x H)	1,483 x 93 x 250 mm (58-1/2 x 3-5/8 x 9-7/8")
Net weight	3.3 - 3.8 kg (7.3 - 8.3 lbs.)

LXT

18V LXT Li-Ion Cordless 80 cm (2.6 ft) 25 mm (1") Concrete Vibrator

DVR350

18V



Vibrator diameter	25 mm (1")
Flexible shaft length	800 mm (2.6 ft)
Vibrations per minute	13,000 min ⁻¹
Dimensions (L x W x H)	1,083 x 93 x 250 mm (42-3/4 x 3-5/8 x 9-7/8")
Net weight	2.9 - 3.3 kg (6.5 - 7.4 lbs.)

LXT

Battery Powered 1.5 m (4.9 ft) 43 mm (1-11/16") Concrete Vibrator

VR001C



Vibrator diameter	43 mm (1-11/16")
Flexible shaft length	1.5 m (4.9 ft)
Vibrations per minute	12,000 min ⁻¹
Continuous run time on full battery charge	w/ PDC1200: 300 min.
Net weight	w/ PDC01 (BL1860B x4): 11.8 kg (26.0 lbs.)

Battery Powered 3.0 m (9.8 ft) 43 mm (1-11/16") Concrete Vibrator

VR002C



Vibrator diameter	43 mm (1-11/16")
Flexible shaft length	3.0 m (9.8 ft)
Vibrations per minute	12,000 min ⁻¹
Continuous run time on full battery charge	w/ PDC1200: 300 min.
Net weight	w/ PDC01 (BL1860B x4): 12.9 kg (28.4 lbs.)

Battery Powered 1.5 m (4.9 ft) 52 mm (2") Concrete Vibrator

VR003C

Vibrator diameter	52 mm (2")
Flexible shaft length	1.5 m (4.9 ft)
Vibrations per minute	12,000 min ⁻¹
Continuous run time on full battery charge	w/ PDC1200: 200 min.
Net weight	w/ PDC01 (BL1860B x4): 12.6 kg (27.8 lbs.)



Battery Powered 3.0 m (9.8 ft) 52 mm (2") Concrete Vibrator

VR004C

Vibrator diameter	52 mm (2")
Flexible shaft length	3.0 m (9.8 ft)
Vibrations per minute	12,000 min ⁻¹
Continuous run time on full battery charge	w/ PDC1200: 200 min.
Net weight	w/ PDC01 (BL1860B x4): 13.7 kg (30.2 lbs.)



40Vmax XGT BL Cordless 240 mm (9-1/2") Variable 2-Speed Mixer

UT001G

40V max

Blade diameter	240 mm (9-1/2")
No load speed	High / Low: 0 - 920 / 0 - 500 min ⁻¹
Dimensions (L x W x H)	w/ Cover L, w/ BL4050F / BL4080F: 414 x 458 x 235 mm (16-1/4 x 18 x 9-1/4")
Net weight	5.7 - 7.0 kg (12.6 - 15.4 lbs.)



40Vmax XGT BL Cordless 240 mm (9-1/2") Variable 2-Speed Mixer with Keyed Chuck

UT002G

40V max

Blade diameter	240 mm (9-1/2")
Chuck capacity	13 mm (1/2")
No load speed	High / Low: 0 - 920 / 0 - 500 min ⁻¹
Dimensions (L x W x H)	w/ Cover L, w/ BL4050F / BL4080F: 404 x 458 x 235 mm (15-7/8 x 18 x 9-1/4")
Net weight	5.8 - 7.2 kg (12.8 - 15.9 lbs.)



18V LXT BL Cordless 165 mm (6-1/2") Variable 2-Speed Mixer

DUT130

18V

Blade diameter	165 mm (6-1/2")
Shank size of tool holder portion	M12 or M14
No load speed	High / Low: 0 - 1,300 / 0 - 350 min ⁻¹
Dimensions (L x W x H)	w/ Mixing blade: 916 x 89 x 231 mm (36 x 3-1/2 x 9-1/8")
Net weight	2.5 - 2.8 kg (5.6 - 6.3 lbs.)



18V LXT BL Cordless Variable 2-Speed Mixer with Keyed Chuck

DUT131

18V

Chuck capacity	1.5 - 13 mm (1/16 - 1/2")
No load speed	High / Low: 0 - 1,300 / 0 - 350 min ⁻¹
Dimensions (L x W x H)	307 x 89 x 231 mm (12-1/8 x 3-1/2 x 9-1/8")
Net weight	2.7 - 3.0 kg (5.8 - 6.6 lbs.)



220 mm (8-5/8") 850 W Mixer

UT2204

Continuous rating Input	850W
Blade diameter	220 mm (8-5/8")
No load speed	550 min ⁻¹
Shank size of tool holder portion	M12 or M14
Dimensions (L x W x H)	929 x 89 x 152 mm (36-1/2 x 3-1/2 x 6")
Net weight	2.7 kg (5.9 lbs.)



165 mm (6-1/2") 850 W Mixer

UT1305

Continuous rating Input	850W
Blade diameter	165 mm (6-1/2")
No load speed	1,300 min ⁻¹
Shank size of tool holder portion	M12
Dimensions (L x W x H)	942 x 87 x 152 mm (37 x 3-7/16 x 6")
Net weight	2.6 kg (5.7 lbs.)



180 mm (7-1/8") 1,800 W Variable 2-Speed Power Mixer

UT1600

Continuous rating Input	1,800W
Mixing capacity	90 kg
Blade diameter	180 mm (7-1/8")
No load speed	High / Low: 0 - 970 / 0 - 440 min ⁻¹
Dimensions (L x W x H)	430 x 180 x 349 mm (17 x 7-1/8 x 13-3/4")
Net weight	7.1 kg (15.7 lbs.)



140 mm (5-1/2") 1,300 W Variable 2-Speed Power Mixer

UT1401

Continuous rating Input	1,300W
Mixing capacity	60 kg
Blade diameter	140 mm (5-1/2")
No load speed	High / Low: 0 - 730 / 0 - 400 min ⁻¹
Dimensions (L x W x H)	430 x 180 x 349 mm (17 x 7-1/8 x 13-3/4")
Net weight	5.5 kg (12.1 lbs.)



Stirring

140 mm (5-1/2") 1,300 W Variable Speed Power Mixer

UT1400

Continuous rating	1,300W
Input	
Mixing capacity	50 kg
Blade diameter	140 mm (5-1/2")
No load speed	0 - 900 min ⁻¹
Dimensions (L x W x H)	430 x 180 x 305 mm (17 x 7-1/8 x 12")
Net weight	5.2 kg (11.5 lbs.)



120 mm (4-3/4") 960 W Variable Speed Power Mixer

UT1200

Continuous rating	960W
Input	
Mixing capacity	40 kg
Blade diameter	120 mm (4-3/4")
No load speed	0 - 590 min ⁻¹
Dimensions (L x W x H)	345 x 180 x 295 mm (13-5/8 x 7-1/8 x 11-5/8")
Net weight	3.2 kg (7 lbs.)



Hammer drilling/Chiselling

Icon

- Double Insulation
- Variable Speed
- Brake
- Reversing
- Anti-restart function
- Mechanical 2-Speed
- Keyless Chuck
- Adapted for SDS-MAX bits
- Adapted for SDS-PLUS bits
- 17mm Hex Shank
- 19mm Hex Shank
- 21mm Hex Shank
- 28.6mm Hex Shank
- 30mm Hex Shank
- Spline Shank
- Torque Limiter
- Constant Speed
- Soft Start
- Dust Collection
- Built-in Job Light
- Carrying Case

40Vmax X2 (80Vmax) XGT BL AFT AWS AVT SOFT NO LOAD Cordless 52 mm (2-1/16") 21.4 J Rotary Hammer, SDS-MAX, Twin LED lights

HR006G

40V max x2



Blows per minute	1,100 - 2,250 min ⁻¹
No load speed	150 - 310 min ⁻¹
Capacity	Concrete (w/ TCT bit): 52 mm (2-1/16")
Impact energy	21.4 J
Dimensions (L x W x H)	w/ BL4040: 610 x 140 x 337 mm (24 x 5-1/2 x 13-1/4")
Net weight	12.9 - 15.5 kg (28.4 - 34.2 lbs.)



40Vmax XGT BL AFT AWS AVT SOFT NO LOAD Cordless 40 mm (1-9/16") Rotary Hammer, SDS-MAX, Twin LED Lights

HR005G

40V max



Blows per minute	1,450 - 2,900 min ⁻¹
No load speed	250 - 500 min ⁻¹
Capacity	Concrete (w/ TCT bit): 40 mm (1-9/16")
Impact energy	8 J
Dimensions (L x W x H)	w/ BL4050F: 520 x 115 x 305 mm (20-1/2 x 4-1/2 x 12")
Net weight	7.4 - 8.8 kg (16.3 - 19.4 lbs.)



40Vmax XGT BL AFT AWS AVT Cordless 30 mm (1-3/16") Combination Hammer, SDS-PLUS, Quick Change Drill Chuck, Twin LED lights

HR009G

40V max



Quick change drill chuck

Blows per minute	0 - 4,500 min ⁻¹
No load speed	0 - 840 min ⁻¹
Capacity	Concrete: 30 mm (1-3/16") Concrete (w/ TCT bit): 30 mm (1-3/16") Steel: 13 mm (1/2") Wood: 32 mm (1-1/4")
Impact energy	3.9 J (2.9 ft.lbs.)
Chuck capacity	1.5 - 13 mm (1/16 - 1/2")
Dimensions (L x W x H)	w/ BL4080F: 457 x 97 x 282 mm (18 x 3-13/16 x 11-1/8")
Net weight	5.3 - 6.7 kg (11.7 - 14.8 lbs.)



40Vmax XGT BL AFT AWS AVT Cordless 30 mm (1-3/16") Combination Hammer, SDS-PLUS, LED light

HR008G

40V max



Blows per minute	0 - 4,500 min ⁻¹
No load speed	0 - 840 min ⁻¹
Capacity	Concrete: 30 mm (1-3/16") Concrete (w/ TCT bit): 30 mm (1-3/16") Steel: 13 mm (1/2") Wood: 32 mm (1-1/4")
Impact energy	3.9 J (2.9 ft.lbs.)
Dimensions (L x W x H)	w/ BL4080F: 441 x 97 x 282 mm (17-3/8 x 3-13/16 x 11-1/8")
Net weight	5.2 - 6.8 kg (11.5 - 15.0 lbs.)



Dust Collection System

DX11 / DX10

DX11
model: HR009G / HR3012FC



DX10
model: HR008G / HR3011FC



HEPA filter



40Vmax XGT BL AFT AWS AVT Cordless 28 mm (1-1/8") Combination Hammer, SDS-PLUS, LED light

HR007G

40V max



Blows per minute	0 - 5,000 min ⁻¹
No load speed	0 - 980 min ⁻¹
Capacity	Concrete: 28 mm (1-1/8") Masonry: 28 mm (1-1/8") Steel: 13 mm (1/2") Wood: 32 mm (1-1/4")
Impact energy	3.0 J (2.2 ft.lbs.)
Dimensions (L x W x H)	w/ BL4050F: 492 x 101 x 261 mm (19-3/8 x 4 x 10-1/4")
Net weight	3.8 - 4.8 kg (8.4 - 10.6 lbs.)



Dust Collection System

DX15

DX15
model: HR007G



HEPA filter

Hammer drilling/Chiselling

40Vmax XGT BL AFT AWS AVT Cordless 28 mm (1-1/8") Combination Hammer, SDS-PLUS, Quick Change Chuck

HR012G

40V max



new

Quick change drill chuck

Blows per minute	0 - 5,000 min ⁻¹
No load speed	0 - 1,130 min ⁻¹
Capacity	Concrete (w/ TCT bit): 28 mm (1-1/8") Steel: 13 mm (1/2") Wood: 32 mm (1-1/4")
Impact energy	3.3 J
Dimensions (L x W x H)	419 x 104 x 223 mm (16-1/2 x 4-1/8 x 8-3/4")
Net weight	4.0 - 5.4 kg (8.8 - 11.9 lbs.)

XGT BL AFT AVT AWS XPT



40Vmax XGT BL AFT AWS AVT Cordless 28 mm (1-1/8") Combination Hammer, SDS-PLUS

HR011G

40V max



new

Blows per minute	0 - 5,000 min ⁻¹
No load speed	0 - 1,130 min ⁻¹
Capacity	Concrete (w/ TCT bit): 28 mm (1-1/8") Steel: 13 mm (1/2") Wood: 32 mm (1-1/4")
Impact energy	3.3 J
Dimensions (L x W x H)	391 x 104 x 223 mm (15-3/8 x 4-1/8 x 8-3/4")
Net weight	3.8 - 5.5 kg (8.4 - 12.1 lbs.)

XGT BL AFT AVT AWS XPT



Dust Collection System

DX17 / DX18

new DX17
model: HR011G

new DX18
model: HR012G



HEPA
filter



40Vmax XGT Cordless 20 mm (13/16") SDS-PLUS Combination Hammer, BL, AWS, AVT, LED light

HR010G

40V max



Blows per minute	0 - 5,000 min ⁻¹
No load speed	0 - 1,350 min ⁻¹
Capacity	Concrete (w/ TCT bit): 20 mm (13/16") Steel: 13 mm (1/2") Wood: 26 mm (1")
Impact energy	2.1 J
Dimensions (L x W x H)	289 x 93 x 217 mm (11-3/8 x 3-5/8 x 8-1/2")
Net weight	2.8 - 4.5 kg (6.2 - 9.9 lbs.)

XGT BL AVT AWS XPT



Dust Collection System

DX16

DX16
model: HR010G / DHR183



HEPA
filter

18V X2 (36V) LXT BL AFT AWS AVT SOFT NO LOAD Cordless 40 mm (1-9/16") Rotary Hammer, SDS-MAX, Twin LED Lights

DHR400

18V x2



Blows per minute	1,450 - 2,900 min ⁻¹
No load speed	250 - 500 min ⁻¹
Capacity	Concrete (w/ TCT bit): 40 mm (1-9/16") Masonry: 40 mm (1-9/16")
Impact energy	8 J
Dimensions (L x W x H)	473 x 120 x 285 mm (18-5/8 x 4-3/4 x 11-1/4")
Net weight	7.3 - 8.1 kg (16.1 - 17.9 lbs.)

LXT BL AFT AVT AWS

SOFT NO LOAD XPT



18V X2 (36V) LXT BL AFT AWS AVT SOFT NO LOAD Cordless 28 mm (1-1/8") Combination Hammer, SDS-PLUS, Quick Change Drill Chuck, Twin LED lights

DHR283

18V x2



Quick change drill chuck

Blows per minute	0 - 5,000 min ⁻¹
No load speed	0 - 980 min ⁻¹
Capacity	Concrete: 28 mm (1-1/8") Masonry: 28 mm (1-1/8") Steel: 13 mm (1/2") Wood: 32 mm (1-1/4") Wood (Self-feed bit): 32 mm (1-1/4")
Impact energy	2.9 J (2.1 ft.lbs.)
Dimensions (L x W x H)	404 x 134 x 232 mm (15-7/8 x 5-1/4 x 9-1/8")
Net weight	4.0 - 4.9 kg (8.8 - 10.8 lbs.)

LXT BL AVT AWS SOFT NO LOAD XPT



18V X2 (36V) LXT BL AFT AWS AVT SOFT NO LOAD Cordless 28 mm (1-1/8") Combination Hammer, SDS-PLUS, Twin LED lights

DHR282

18V x2



Blows per minute	0 - 5,000 min ⁻¹
No load speed	0 - 980 min ⁻¹
Capacity	Concrete: 28 mm (1-1/8") Masonry: 28 mm (1-1/8") Steel: 13 mm (1/2") Wood: 32 mm (1-1/4") Wood (Self-feed bit): 32 mm (1-1/4")
Impact energy	2.8 J (2.1 ft.lbs.)
Dimensions (L x W x H)	373 x 134 x 232 mm (14-3/4 x 5-1/4 x 9-1/8")
Net weight	3.9 - 5.0 kg (8.6 - 11.0 lbs.)

LXT BL AVT AWS SOFT NO LOAD XPT



18V X2 (36V) LXT BL AFT AWS AVT SOFT NO LOAD Cordless 28 mm (1-1/8") Combination Hammer, SDS-PLUS, Quick Change Drill Chuck, Twin LED lights

DHR281

18V x2



Quick change drill chuck

Blows per minute	0 - 5,000 min ⁻¹
No load speed	0 - 980 min ⁻¹
Capacity	Concrete: 28 mm (1-1/8") Masonry: 28 mm (1-1/8") Steel: 13 mm (1/2") Wood: 32 mm (1-1/4") Wood (Self-feed bit): 32 mm (1-1/4")
Impact energy	2.9 J (2.1 ft.lbs.)
Dimensions (L x W x H)	404 x 134 x 232 mm (15-7/8 x 5-1/4 x 9-1/8")
Net weight	4.0 - 4.9 kg (8.8 - 10.8 lbs.)

LXT BL AVT AWS SOFT NO LOAD XPT



Hammer drilling/Chiselling

Hammer drilling/
Chiselling

18V X2 (36V) LXT BL AVT SOFT NO LOAD Cordless 28 mm (1-1/8") Combination Hammer, SDS-PLUS, Twin LED lights

DHR280

18V x2



Blows per minute	0 - 5,000 min ⁻¹
No load speed	0 - 980 min ⁻¹
Capacity	Concrete: 28 mm (1-1/8") Masonry: 28 mm (1-1/8") Steel: 13 mm (1/2") Wood: 32 mm (1-1/4") Wood (Self-feed bit): 32 mm (1-1/4")
Impact energy	2.8 J (2.1 ft.lbs.)
Dimensions (L x W x H)	373 x 134 x 232 mm (14-3/4 x 5-1/4 x 9-1/8")
Net weight	3.8 - 4.9 kg (8.4 - 10.8 lbs.)



Dust Extraction System

DX08 / DX09

DX08 model: DHR283 / DHR281

DX19 model: DHR282 / DHR280



HEPA filter

18V X2 (36V) LXT Cordless 26 mm (1") Combination Hammer, SDS-PLUS, Quick Change Drill Chuck, LED light

DHR264

18V x2



Quick change drill chuck

Blows per minute	0 - 5,000 min ⁻¹
No load speed	0 - 1,250 min ⁻¹
Capacity	Concrete: 26 mm (1") Masonry: 26 mm (1") Steel: 13 mm (1/2") Wood: 32 mm (1-1/4") Wood (Self-feed bit): 32 mm (1-1/4")
Impact energy	2.5 J (1.8 ft.lbs.)
Dimensions (L x W x H)	374 x 116 x 232 mm (14-3/4 x 4-9/16 x 9-1/8")
Net weight	4.2 - 5.1 kg (9.2 - 11.2 lbs.)



18V X2 (36V) LXT Cordless 26 mm (1") Combination Hammer, SDS-PLUS, LED light

DHR263

18V x2



Blows per minute	0 - 5,000 min ⁻¹
No load speed	0 - 1,250 min ⁻¹
Capacity	Concrete: 26 mm (1") Masonry: 26 mm (1") Steel: 13 mm (1/2") Wood: 32 mm (1-1/4") Wood (Self-feed bit): 32 mm (1-1/4")
Impact energy	2.5 J
Dimensions (L x W x H)	350 x 116 x 232 mm (13-3/4 x 4-9/16 x 9-1/8")
Net weight	4.1 - 5.1 kg (9 - 11.3 lbs.)



18V LXT BL Brushless Cordless 24 mm (15/16") Combination Hammer, SDS-PLUS, Quick Change Drill Chuck

DHR243

18V



Quick change drill chuck

Blows per minute	0 - 4,700 min ⁻¹
No load speed	0 - 950 min ⁻¹
Capacity	Concrete: 24 mm (15/16") Masonry: 24 mm (15/16") Steel: 13 mm (1/2") Wood: 27 mm (1-1/16") Wood (Self-feed bit): 27 mm (1-1/16")
Impact energy	2.0 J
Dimensions (L x W x H)	353 x 85 x 213 mm (13-7/8 x 3-3/8 x 8-3/8")
Net weight	3.2 - 3.7 kg (6.9 - 8.3 lbs.)



18V LXT BL Brushless Cordless 24 mm (15/16") Combination Hammer, SDS-PLUS

DHR242

18V



Blows per minute	0 - 4,700 min ⁻¹
No load speed	0 - 950 min ⁻¹
Capacity	Concrete: 24 mm (15/16") Masonry: 24 mm (15/16") Steel: 13 mm (1/2") Wood: 27 mm (1-1/16") Wood (Self-feed bit): 27 mm (1-1/16")
Impact energy	2 J
Dimensions (L x W x H)	328 x 85 x 213 mm (12-7/8 x 3-3/8 x 8-3/8")
Net weight	3.1 - 3.8 kg (6.7 - 8.4 lbs.)



18V LXT Li-Ion Cordless 20 mm (13/16") Combination Hammer, SDS-PLUS

DHR241

18V



Blows per minute	0 - 4,000 min ⁻¹
No load speed	0 - 1,100 min ⁻¹
Capacity	Concrete: 20 mm (13/16") Masonry: 20 mm (13/16") Steel: 13 mm (1/2") Wood: 26 mm (1") Wood (Self-feed bit): 26 mm (1")
Impact energy	2.0 J
Dimensions (L x W x H)	417 x 84 x 219 mm (16-3/8 x 3-5/16 x 8-5/8")
Net weight	3.2 - 4 kg (7.1 - 8.8 lbs.)



18V LXT Li-Ion Cordless 20 mm (13/16") Combination Hammer, SDS-PLUS, LED light

DHR202

18V



Blows per minute	0 - 4,000 min ⁻¹
No load speed	0 - 1,200 min ⁻¹
Capacity	Concrete: 20 mm (13/16") Masonry: 20 mm (13/16") Steel: 13 mm (1/2") Wood: 26 mm (1") Wood (Self-feed bit): 26 mm (1")
Impact energy	1.9 J (1.5 ft.lbs.)
Dimensions (L x W x H)	358 x 84 x 259 mm (14-1/8 x 3-5/16 x 10-1/4")
Net weight	3.2 - 4 kg (7.1 - 8.8 lbs.)



18V LXT BL AVT Cordless 18 mm (11/16") Rotary Hammer, SDS-PLUS, LED light

DHR183

18V



Blows per minute	0 - 5,000 min ⁻¹
No load speed	0 - 1,100 min ⁻¹
Capacity	Concrete: 18 mm (11/16") Steel: 13 mm (1/2") Wood: 24 mm (15/16")
Impact energy	1.7 J
Dimensions (L x W x H)	288 x 89 x 215 mm (11-3/8 x 3-1/2 x 8-1/2")
Net weight	2.9 kg (6.4 lbs.)



18V LXT BL AWS AVT Cordless 18 mm (11/16") Combination Hammer, SDS-PLUS, Twin LED lights

DHR182

18V



Blows per minute	0 - 5,000 min ⁻¹
No load speed	0 - 1,350 min ⁻¹
Capacity	Concrete: 18 mm (11/16") Masonry: 18 mm (11/16") Steel: 13 mm (1/2") Wood: 24 mm (15/16")
Impact energy	1.7 J (1.3 ft.lbs.)
Dimensions (L x W x H)	301 x 82 x 285 mm (11-7/8 x 3-1/4 x 11-1/4")
Net weight	2.7 kg (6.0 lbs.)



The weight may differ depending on the attachment(s), including the battery cartridge.

Hammer drilling/Chiselling

18V LXT BL Brushless Cordless 17 mm (11/16") Rotary Hammer, SDS-PLUS, LED light

DHR171

18V



Blows per minute	0 - 4,800 min ⁻¹
No load speed	0 - 680 min ⁻¹
Capacity	Concrete: 17 mm (11/16") Masonry: 17 mm (11/16") Steel: 10 mm (3/8") Wood: 13 mm (1/2")
Impact energy	1.2 J
Dimensions (L x W x H)	w/ BL1830B / BL1840B / BL1850B / BL1860B: 273 x 86 x 211 mm (10-3/4 x 3-3/8 x 8-5/16")
Net weight	2.1 - 2.8 kg (4.6 - 6.2 lbs.)

LXT **BL** **MOTOR**



18V LXT Li-Ion Cordless 16 mm (5/8") Rotary Hammer, SDS-PLUS, LED light

DHR165

18V



Blows per minute	0 - 5,300 min ⁻¹
No load speed	0 - 1,600 min ⁻¹
Capacity	Concrete (w/ TCT bit): 16 mm (5/8") Masonry: 16 mm (5/8") Steel: 13 mm (1/2") Wood: 24 mm (15/16")
Impact energy	1.3 J
Dimensions (L x W x H)	297 x 79 x 253 mm (11-3/4 x 3-1/8 x 10")
Net weight	2.3 - 3 kg (5 - 6.6 lbs.)

LXT **XPT**



12V max CXT BL Cordless 16 mm (5/8") Rotary Hammer, SDS-PLUS, LED light

HR166D

12V max



Blows per minute	0 - 4,800 min ⁻¹
No load speed	0 - 680 min ⁻¹
Capacity	Concrete: 16 mm (5/8") Masonry: 16 mm (5/8") Steel: 10 mm (3/8") Wood: 13 mm (1/2")
Impact energy	1.1 J
Dimensions (L x W x H)	w/ BL1041B: 250 x 74 x 206 mm (9-7/8 x 2-15/16 x 8-1/8")
Net weight	1.8 - 2.0 kg (4.0 - 4.4 lbs.)

CXT **BL** **MOTOR**



12V max CXT Cordless 14 mm (9/16") Rotary Hammer, SDS-PLUS, LED light

HR140D

12V max



Impacts per minute	0 - 4,900 min ⁻¹
No load speed	0 - 850 min ⁻¹
Capacity	Concrete: 14 mm (9/16") Masonry: 14 mm (9/16") Steel: 10 mm (3/8") Wood: 13 mm (1/2")
Impact energy	1.0 J
Chuck capacity	1.5 - 13 mm (1/16 - 1/2")
Dimensions (L x W x H)	w/ BL1041B: 246 x 74 x 198 mm (9-11/16 x 2-15/16 x 7-3/4")
Net weight	1.9 - 2.6 kg (4.3 - 5.6 lbs.)

CXT



52 mm (2") 19.1 J AVT SOFT NO LOAD Rotary Hammer, SDS-MAX

HR5212C



Continuous rating	1,510W
Input	
Blows per minute	1,100 - 2,250 min ⁻¹
No load speed	150 - 310 min ⁻¹
Capacity	Concrete (w/ TCT bit): 52 mm (2") Masonry: 52 mm (2")
Impact energy	19.1 J
Dimensions (L x W x H)	599 x 140 x 287 mm (23-1/2 x 5-1/2 x 11-1/4")
Net weight	11.9 kg (26.2 lbs.)

AVT **SOFT** **NO LOAD**



52 mm (2") 20.0 J Rotary Hammer, SDS-MAX

HR5202C



Continuous rating	1,510W
Input	
Blows per minute	1,100 - 2,250 min ⁻¹
No load speed	150 - 310 min ⁻¹
Capacity	Concrete (w/ TCT bit): 52 mm (2") Masonry: 52 mm (2")
Impact energy	20.0 J
Dimensions (L x W x H)	599 x 134 x 287 mm (23-1/2 x 5-1/4 x 11-1/4")
Net weight	10.9 - 11.1 kg (24.1 - 24.4 lbs.)



45 mm (1-3/4") 9.4 J AVT Rotary Hammer, SDS-MAX

HR4511C



Continuous rating	1,350W
Input	
Blows per minute	1,250 - 2,750 min ⁻¹
No load speed	130 - 280 min ⁻¹
Capacity	Concrete (w/ TCT bit): 45 mm (1-3/4") Masonry: 45 mm (1-3/4")
Impact energy	9.4 J
Dimensions (L x W x H)	458 x 136 x 288 mm (18 x 5-3/8 x 11-3/8")
Net weight	9 - 9.1 kg (19.8 - 20.1 lbs.)

AVT



45 mm (1-3/4") 9.4 J AVT Rotary Hammer, SDS-MAX

HR4510C



Continuous rating	1,350W
Input	
Blows per minute	1,250 - 2,750 min ⁻¹
No load speed	130 - 280 min ⁻¹
Capacity	Concrete (w/ TCT bit): 45 mm (1-3/4") Masonry: 45 mm (1-3/4")
Impact energy	9.4 J
Dimensions (L x W x H)	458 x 136 x 288 mm (16-7/8 x 4-1/4 x 11-3/8")
Net weight	8.9 - 9 kg (19.5 - 19.9 lbs.)

AVT



45 mm (1-3/4") 10.1 J Rotary Hammer, SDS-MAX

HR4501C



Continuous rating	1,350W
Input	
Blows per minute	1,250 - 2,750 min ⁻¹
No load speed	130 - 280 min ⁻¹
Capacity	Concrete (w/ TCT bit): 45 mm (1-3/4") Masonry: 45 mm (1-3/4")
Impact energy	10.1 J
Dimensions (L x W x H)	458 x 121 x 288 mm (18 x 4-3/4 x 11-3/8")
Net weight	8.2 - 8.4 kg (18.1 - 18.5 lbs.)



40 mm (1-9/16") Rotary Hammer, Spline Shank

HR4041C



Continuous rating	1,100W
Input	
Blows per minute	1,300 - 2,600 min ⁻¹
No load speed	230 - 460 min ⁻¹
Capacity	Concrete (w/ TCT bit): 40 mm (1-9/16") Masonry: 40 mm (1-9/16")
Dimensions (L x W x H)	428 x 107 x 247 mm (16-7/8 x 4-1/4 x 9-3/4")
Net weight	6.7 kg (14.8 lbs.)



Hammer drilling/Chiselling

Hammer drilling/Chiselling

40 mm (1-9/16") Rotary Hammer, 17 mm Hex Shank

HR4030C



Continuous rating	1,100W
Input	
Blows per minute	1,300 - 2,600 min ⁻¹
No load speed	230 - 460 min ⁻¹
Capacity	Concrete (w/ TCT bit): 40 mm (1-9/16") Masonry: 40 mm (1-9/16")
Dimensions (L x W x H)	413 x 107 x 247 mm (16-1/4 x 4-1/4 x 9-3/4")
Net weight	6.9 kg (15.2 lbs.)



40 mm (1-9/16") 8.3 J Rotary Hammer, SDS-MAX

HR4003C



Continuous rating	1,100W
Input	
Blows per minute	1,450 - 2,900 min ⁻¹
No load speed	250 - 500 min ⁻¹
Capacity	Concrete (w/ TCT bit): 40 mm (1-9/16") Masonry: 40 mm (1-9/16")
Impact energy	8.3 J
Dimensions (L x W x H)	479 x 106 x 263 mm (18-11/16 x 4-3/16 x 10-3/8")
Net weight	6.2 - 6.4 kg (13.7 - 14.1 lbs.)



40 mm (1-9/16") 8.0 J AVT SOFT NO LOAD Rotary Hammer, SDS-MAX

HR4013C



Continuous rating	1,100W
Input	
Blows per minute	1,450 - 2,900 min ⁻¹
No load speed	250 - 500 min ⁻¹
Capacity	Concrete (w/ TCT bit): 40 mm (1-9/16") Masonry: 40 mm (1-9/16")
Impact energy	8.0 J
Dimensions (L x W x H)	479 x 112 x 263 mm (18-11/16 x 4-3/8 x 10-3/8")
Net weight	6.8 kg (14.9 lbs.)

AVT SOFT NOLOAD



40 mm (1-9/16") 6.1 J Rotary Hammer, SDS-MAX

HR4002



Continuous rating	1,050W
Input	
Blows per minute	2,500 min ⁻¹
No load speed	680 min ⁻¹
Capacity	Concrete (w/ TCT bit): 40 mm (1-9/16") Masonry: 40 mm (1-9/16")
Impact energy	6.1 J
Dimensions (L x W x H)	458 x 114 x 256 mm (18 x 4-1/2 x 10-1/8")
Net weight	6.6 - 6.8 kg (14.6 - 15 lbs.)



35 mm (1-3/8") Rotary Hammer, 17 mm Hex Shank

HR3530



Continuous rating	1,010W
Input	
Blows per minute	3,100 min ⁻¹
No load speed	760 min ⁻¹
Capacity	Concrete (w/ TCT bit): 35 mm (1-3/8") Masonry: 35 mm (1-3/8")
Dimensions (L x W x H)	374 x 100 x 243 mm (14-3/4 x 3-15/16 x 9-9/16")
Net weight	5.8 kg (12.8 lbs.)



35 mm (1-3/8") 5.7 J AVT Combination Hammer, SDS-MAX, LED Job Light

HR3541FC



Continuous rating	850W
Input	
Blows per minute	1,650 - 3,300 min ⁻¹
No load speed	315 - 630 min ⁻¹
Capacity	Concrete (w/ TCT bit): 35 mm (1-3/8") Masonry: 35 mm (1-3/8") Steel: 13 mm (1/2") Wood: 32 mm (1-1/4") Wood (Self-feed bit): 32 mm (1-1/4")
Impact energy	5.7 J
Dimensions (L x W x H)	439 x 114 x 239 mm (17-1/4 x 4-1/2 x 9-3/8")
Net weight	5.6 kg (12.3 lbs.)

AVT



35 mm (1-3/8") 5.6 J Combination Hammer, SDS-MAX

HR3540C



Continuous rating	850W
Input	
Blows per minute	1,650 - 3,300 min ⁻¹
No load speed	315 - 630 min ⁻¹
Capacity	Concrete (w/ TCT bit): 35 mm (1-3/8") Masonry: 35 mm (1-3/8") Steel: 13 mm (1/2") Wood: 32 mm (1-1/4") Wood (Self-feed bit): 32 mm (1-1/4")
Impact energy	5.6 J
Dimensions (L x W x H)	439 x 108 x 239 mm (17-1/4 x 4-1/4 x 9-3/8")
Net weight	5.2 - 5.3 kg (11.4 - 11.6 lbs.)



32 mm (1-1/4") 4.9 J AVT Combination Hammer, SDS-PLUS, Quick Change Drill Chuck, LED Job Light

HR3210FC



Quick change drill chuck

Continuous rating	850W
Input	
Blows per minute	1,650 - 3,300 min ⁻¹
No load speed	315 - 630 min ⁻¹
Capacity	Concrete (w/ TCT bit): 32 mm (1-1/4") Masonry: 32 mm (1-1/4") Steel: 13 mm (1/2") Wood: 32 mm (1-1/4") Wood (Self-feed bit): 32 mm (1-1/4")
Impact energy	4.9 J
Dimensions (L x W x H)	424 x 114 x 239 mm (16-3/4 x 4-1/2 x 9-3/8")
Net weight	5.4 - 5.6 kg (11.9 - 12.3 lbs.)

AVT



32 mm (1-1/4") 5.0 J AVT Combination Hammer, SDS-PLUS

HR3210C



Continuous rating	850W
Input	
Blows per minute	1,650 - 3,300 min ⁻¹
No load speed	315 - 630 min ⁻¹
Capacity	Concrete (w/ TCT bit): 32 mm (1-1/4") Masonry: 32 mm (1-1/4") Steel: 13 mm (1/2") Wood: 32 mm (1-1/4") Wood (Self-feed bit): 32 mm (1-1/4")
Impact energy	5.0 J
Dimensions (L x W x H)	398 x 114 x 239 mm (15-5/8 x 4-1/4 x 9-3/8")
Net weight	5.2 - 5.6 kg (11.4 - 12.4 lbs.)

AVT



32 mm (1-1/4") 5.1 J Combination Hammer, SDS-PLUS

HR3200C



Continuous rating	850W
Input	
Blows per minute	1,650 - 3,300 min ⁻¹
No load speed	315 - 630 min ⁻¹
Capacity	Concrete (w/ TCT bit): 32 mm (1-1/4") Masonry: 32 mm (1-1/4") Steel: 13 mm (1/2") Wood: 32 mm (1-1/4") Wood (Self-feed bit): 32 mm (1-1/4")
Impact energy	5.1 J
Dimensions (L x W x H)	398 x 108 x 239 mm (15-5/8 x 4-1/4 x 9-3/8")
Net weight	4.8 - 5.2 kg (10.5 - 11.5 lbs.)



Hammer drilling/Chiselling

30 mm (1-3/16") 3.9 J AVT Combination Hammer, SDS-PLUS, Quick Change Drill Chuck, LED Light

HR3012FC



Quick change drill chuck

Continuous rating Input	1,050W
Blows per minute	0 - 4,500 min ⁻¹
No load speed	0 - 840 min ⁻¹
Capacity	Concrete (w/ TCT bit): 30 mm (1-3/16") Masonry: 30 mm (1-3/16") Steel: 13 mm (1/2") Wood: 32 mm (1-1/4")
Impact energy	3.9 J
Chuck capacity	1.5 - 13 mm (1/16 - 1/2")
Dimensions (L x W x H)	386 x 98 x 242 mm (15-1/4 x 3-7/8 x 9-1/2")
Net weight	4.5 - 4.7 kg (9.9 - 10.4 lbs.)

AVT



30 mm (1-3/16") 3.9 J AVT Combination Hammer, SDS-PLUS, LED Light

HR3011FC



Continuous rating Input	1,050W
Blows per minute	0 - 4,500 min ⁻¹
No load speed	0 - 840 min ⁻¹
Capacity	Concrete (w/ TCT bit): 30 mm (1-3/16") Masonry: 30 mm (1-3/16") Steel: 13 mm (1/2") Wood: 32 mm (1-1/4")
Impact energy	3.9 J
Chuck capacity	1.5 - 13 mm (1/16 - 1/2")
Dimensions (L x W x H)	369 x 98 x 242 mm (14-1/2 x 3-7/8 x 9-1/2")
Net weight	4.4 - 4.8 kg (9.7 - 10.6 lbs.)

AVT



30 mm (1-3/16") 3.9 J Combination Hammer, SDS-PLUS

HR3001C



Continuous rating Input	1,050W
Blows per minute	0 - 4,500 min ⁻¹
No load speed	0 - 840 min ⁻¹
Capacity	Concrete (w/ TCT bit): 30 mm (1-3/16") Masonry: 30 mm (1-3/16") Steel: 13 mm (1/2") Wood: 32 mm (1-1/4") Wood (Self-feed bit): 32 mm (1-1/4")
Impact energy	3.9 J
Chuck capacity	1.5 - 13 mm (1/16 - 1/2")
Dimensions (L x W x H)	369 x 98 x 226 mm (14-1/2 x 3-7/8 x 8-7/8")
Net weight	4.1 - 4.5 kg (9.0 - 9.9 lbs.)



28 mm (1-1/8") 2.9 J Combination Hammer, SDS-PLUS, Quick Change Drill Chuck, LED Light

HR2811FT



Quick change drill chuck

Continuous rating Input	800W
Blows per minute	0 - 4,500 min ⁻¹
No load speed	0 - 1,100 min ⁻¹
Capacity	Concrete (w/ TCT bit): 28 mm (1-1/8") Masonry: 28 mm (1-1/4") Steel: 13 mm (1/2") Wood: 32 mm (1-1/4") Wood (Self-feed bit): 32 mm (1-1/4")
Impact energy	2.9 J
Dimensions (L x W x H)	345 x 89 x 225 mm (13-5/8 x 3-1/2 x 8-7/8")
Net weight	3.6 - 3.9 kg (8 - 8.6 lbs.)



28 mm (1-1/8") 2.8 J Combination Hammer, SDS-PLUS, LED Light

HR2811F



Continuous rating Input	800W
Blows per minute	0 - 4,500 min ⁻¹
No load speed	0 - 1,100 min ⁻¹
Capacity	Concrete (w/ TCT bit): 28 mm (1-1/8") Masonry: 28 mm (1-1/8") Steel: 13 mm (1/2") Wood: 32 mm (1-1/4") Wood (Self-feed bit): 32 mm (1-1/4")
Impact energy	2.8 J
Dimensions (L x W x H)	320 x 89 x 225 mm (12-5/8 x 3-1/2 x 8-7/8")
Net weight	3.5 - 3.9 kg (7.7 - 8.7 lbs.)



28 mm (1-1/8") 2.9 J Combination Hammer, SDS-PLUS, Quick Change Drill Chuck

HR2810T



Quick change drill chuck

Continuous rating Input	800W
Blows per minute	0 - 4,500 min ⁻¹
No load speed	0 - 1,100 min ⁻¹
Capacity	Concrete (w/ TCT bit): 28 mm (1-1/8") Masonry: 28 mm (1-1/8") Steel: 13 mm (1/2") Wood: 32 mm (1-1/4") Wood (Self-feed bit): 32 mm (1-1/4")
Impact energy	2.9 J
Dimensions (L x W x H)	339 x 89 x 225 mm (13-3/8 x 3-1/2 x 8-7/8")
Net weight	3.5 - 3.8 kg (7.8 - 8.4 lbs.)



28 mm (1-1/8") 2.8 J Combination Hammer, SDS-PLUS

HR2810



Continuous rating Input	800W
Blows per minute	0 - 4,500 min ⁻¹
No load speed	0 - 1,100 min ⁻¹
Capacity	Concrete (w/ TCT bit): 28 mm (1-1/8") Masonry: 28 mm (1-1/8") Steel: 13 mm (1/2") Wood: 32 mm (1-1/4") Wood (Self-feed bit): 32 mm (1-1/4")
Impact energy	2.8 J
Dimensions (L x W x H)	314 x 89 x 225 mm (12-3/8 x 3-1/2 x 8-7/8")
Net weight	3.4 - 3.8 kg (7.5 - 8.5 lbs.)



28 mm (1-1/8") 2.8 J Rotary Hammer, SDS-PLUS

HR2800



Continuous rating Input	800W
Blows per minute	0 - 4,500 min ⁻¹
No load speed	0 - 1,100 min ⁻¹
Capacity	Concrete (w/ TCT bit): 28 mm (1-1/8") Masonry: 28 mm (1-1/8") Steel: 13 mm (1/2") Wood: 32 mm (1-1/4") Wood (Self-feed bit): 32 mm (1-1/4")
Impact energy	2.8 J
Dimensions (L x W x H)	314 x 89 x 225 mm (12-3/8 x 3-1/2 x 8-7/8")
Net weight	3.4 - 3.8 kg (7.4 - 8.4 lbs.)



26 mm (1") 3.0 J Combination Hammer, SDS-PLUS, Quick Change Chuck, LED Light

HR2670FT



Quick change drill chuck

Continuous rating Input	800W
Blows per minute	0 - 4,500 min ⁻¹
No load speed	0 - 1,500 min ⁻¹
Capacity	Concrete (w/ TCT bit): 26 mm (1") Steel: 13 mm (1/2") Wood: 32 mm (1-1/4")
Impact energy	3.0 J
Dimensions (L x W x H)	390 x 77 x 207 mm (15-3/8 x 3 x 8-1/8")
Net weight	3.1 - 3.3 kg (6.8 - 7.3 lbs.)



26 mm (1") 3.0 J Combination Hammer, SDS-PLUS

HR2670



Continuous rating Input	800W
Blows per minute	0 - 4,500 min ⁻¹
No load speed	0 - 1,500 min ⁻¹
Capacity	Concrete (w/ TCT bit): 26 mm (1") Steel: 13 mm (1/2") Wood: 32 mm (1-1/4")
Impact energy	3.0 J
Dimensions (L x W x H)	362 x 77 x 207 mm (14-1/4 x 3 x 8-1/8")
Net weight	2.9 - 3.4 kg (6.4 - 7.5 lbs.)



Hammer drilling/Chiselling

26 mm (1") 2.4 J AVT D-Handle Combination Hammer, SDS-PLUS

HR2641



Continuous rating Input	800W
Blows per minute	0 - 4,500 min ⁻¹
No load speed	0 - 1,100 min ⁻¹
Capacity	Concrete (w/ TCT bit): 26 mm (1") Masonry: 26 mm (1") Steel: 13 mm (1/2") Wood: 32 mm (1-1/4") Wood (Self-feed bit): 32 mm (1-1/4")
Impact energy	2.4 J
Dimensions (L x W x H)	422 x 76 x 156 mm (16-5/8 x 3 x 6-1/8")
Net weight	3.1 - 3.5 kg (6.8 - 7.7 lbs.)

AVT



26 mm (1") 2.4 J AVT Combination Hammer, SDS-PLUS, Quick Change Chuck, LED Light

HR2631FT



Quick change drill chuck

Continuous rating Input	800W
Blows per minute	0 - 4,600 min ⁻¹
No load speed	0 - 1,200 min ⁻¹
Capacity	Concrete (w/ TCT bit): 26 mm (1") Masonry: 26 mm (1") Steel: 13 mm (1/2") Wood: 32 mm (1-1/4") Wood (Self-feed bit): 32 mm (1-1/4")
Impact energy	2.4 J
Dimensions (L x W x H)	385 x 77 x 209 mm (15-1/8 x 3 x 8-1/4")
Net weight	3.1 kg (6.8 lbs.)

AVT



26 mm (1") 2.4 J AVT Combination Hammer, SDS-PLUS, LED Light

HR2631F



Continuous rating Input	800W
Blows per minute	0 - 4,600 min ⁻¹
No load speed	0 - 1,200 min ⁻¹
Capacity	Concrete (w/ TCT bit): 26 mm (1") Masonry: 26 mm (1") Steel: 13 mm (1/2") Wood: 32 mm (1-1/4") Wood (Self-feed bit): 32 mm (1-1/4")
Impact energy	2.4 J
Dimensions (L x W x H)	361 x 77 x 209 mm (14-1/4 x 3 x 8-1/4")
Net weight	2.9 kg (6.4 lbs.)

AVT



26 mm (1") 2.4 J AVT Rotary Hammer, SDS-PLUS

HR2601



Continuous rating Input	800W
Blows per minute	0 - 4,600 min ⁻¹
No load speed	0 - 1,200 min ⁻¹
Capacity	Concrete (w/ TCT bit): 26 mm (1") Masonry: 26 mm (1") Steel: 13 mm (1/2") Wood: 32 mm (1-1/4") Wood (Self-feed bit): 32 mm (1-1/4")
Impact energy	2.4 J
Dimensions (L x W x H)	361 x 77 x 209 mm (14-1/4 x 3 x 8-1/4")
Net weight	3.1 - 3.6 kg (6.9 - 7.8 lbs.)

AVT



26 mm (1") 2.4 J Rotary Hammer, SDS-PLUS

HR2600



Continuous rating Input	800W
Blows per minute	0 - 4,600 min ⁻¹
No load speed	0 - 1,200 min ⁻¹
Capacity	Concrete (w/ TCT bit): 26 mm (1") Masonry: 26 mm (1") Steel: 13 mm (1/2") Wood: 32 mm (1-1/4") Wood (Self-feed bit): 32 mm (1-1/4")
Impact energy	2.4 J
Dimensions (L x W x H)	361 x 77 x 209 mm (14-1/4 x 3 x 8-1/4")
Net weight	2.8 kg (6.2 lbs.)

AVT



26 mm (1") 2.2 J AVT Combination Hammer with HEPA Self Dust Collection, SDS-PLUS, Quick Change Chuck

HR2653T



Quick change drill chuck

Continuous rating Input	800W
Blows per minute	0 - 4,600 min ⁻¹
No load speed	0 - 1,200 min ⁻¹
Capacity	Concrete: 26 mm (1") Steel: 13 mm (1/2") Wood: 32 mm (1-1/4") Wood (Self-feed bit): 32 mm (1-1/4")
Impact energy	2.2 J
Dimensions (L x W x H)	630 x 89 x 260 mm (24-3/4 x 3-1/2 x 10-1/4")
Net weight	3.2 - 4.5 kg (7.2 - 9.9 lbs.)

AVT



26 mm (1") 2.2 J AVT Combination Hammer with HEPA Self Dust Collection, SDS-PLUS

HR2653



Continuous rating Input	800W
Blows per minute	0 - 4,600 min ⁻¹
No load speed	0 - 1,200 min ⁻¹
Capacity	Concrete: 26 mm (1") Steel: 13 mm (1/2") Wood: 32 mm (1-1/4") Wood (Self-feed bit): 32 mm (1-1/4")
Impact energy	2.2 J
Dimensions (L x W x H)	604 x 89 x 260 mm (23-3/4 x 3-1/2 x 10-1/4")
Net weight	3.1 - 4.3 kg (6.9 - 9.6 lbs.)

AVT



26 mm (1") 2.2 J Combination Hammer with HEPA Self Dust Collection, SDS-PLUS

HR2652



Continuous rating Input	800W
Blows per minute	0 - 4,600 min ⁻¹
No load speed	0 - 1,200 min ⁻¹
Capacity	Concrete: 26 mm (1") Steel: 13 mm (1/2") Wood: 32 mm (1-1/4") Wood (Self-feed bit): 32 mm (1-1/4")
Impact energy	2.2 J
Dimensions (L x W x H)	604 x 89 x 260 mm (23-3/4 x 3-1/2 x 10-1/4")
Net weight	3 - 4.3 kg (6.7 - 9.4 lbs.)



26 mm (1") 2.2 J AVT D-Handle Combination Hammer with HEPA Self Dust Collection, SDS-PLUS

HR2663



Continuous rating Input	800W
Blows per minute	0 - 4,500 min ⁻¹
No load speed	0 - 1,100 min ⁻¹
Capacity	Concrete: 26 mm (1") Steel: 13 mm (1/2") Wood: 32 mm (1-1/4") Wood (Self-feed bit): 32 mm (1-1/4")
Impact energy	2.2 J
Dimensions (L x W x H)	666 x 89 x 260 mm (26-1/4 x 3-1/2 x 10-1/4")
Net weight	3.3 - 4.6 kg (7.3 - 10.0 lbs.)

AVT



Hammer drilling/Chiselling

24 mm (15/16") 2.3 J D-Handle Combination Hammer, SDS-PLUS

HR2475

Continuous rating Input	780W
Blows per minute	0 - 4,500 min ⁻¹
No load speed	0 - 1,100 min ⁻¹
Capacity	Concrete (w/TCT bit): 24 mm (15/16") Masonry: 24 mm (15/16") Steel: 13 mm (1/2") Wood: 32 mm (1-1/4") Wood (Self-feed bit): 32 mm (1-1/4")
Impact energy	2.3 J
Dimensions (L x W x H)	429 x 84 x 158 mm (16-7/8 x 3-5/16 x 6-1/4")
Net weight	3.0 - 3.4 kg (6.6 - 7.5 lbs.)



23 mm (7/8") 2.3 J Combination Hammer, SDS-PLUS, Quick Change Drill Chuck

HR2320T

Continuous rating Input	720W
Blows per minute	0 - 4,600 min ⁻¹
No load speed	0 - 1,200 min ⁻¹
Capacity	Concrete: 23 mm (7/8") Masonry: 23 mm (7/8") Steel: 13 mm (1/2") Wood: 32 mm (1-1/4") Wood (Self-feed bit): 32 mm (1-1/4")
Impact energy	2.3 J
Dimensions (L x W x H)	380 x 77 x 209 mm (15 x 3 x 8-1/4")
Net weight	2.9 - 3.2 kg (6.4 - 7 lbs.)



Quick change drill chuck



23 mm (7/8") 2.3 J Rotary Hammer, SDS-PLUS

HR2300

Continuous rating Input	720W
Blows per minute	0 - 4,600 min ⁻¹
No load speed	0 - 1,200 min ⁻¹
Capacity	Concrete (w/TCT bit): 23 mm (7/8") Masonry: 23 mm (7/8") Steel: 13 mm (1/2") Wood: 32 mm (1-1/4") Wood (Self-feed bit): 32 mm (1-1/4")
Impact energy	2.3 J
Dimensions (L x W x H)	356 x 77 x 209 mm (14 x 3 x 8-1/4")
Net weight	2.7 kg (5.9 lbs.)



22 mm (7/8") 2.2 J Rotary Hammer, SDS-PLUS

HR2230

Continuous rating Input	710W
Blows per minute	0 - 4,050 min ⁻¹
No load speed	0 - 1,050 min ⁻¹
Capacity	Concrete (w/TCT bit): 22 mm (7/8") Masonry: 22 mm (7/8") Steel: 13 mm (1/2") Wood: 32 mm (1-1/4") Wood (Self-feed bit): 32 mm (1-1/4")
Impact energy	2.2 J
Dimensions (L x W x H)	357 x 84 x 214 mm (14 x 3-5/16 x 8-3/8")
Net weight	2.6 - 3.1 kg (5.8 - 6.8 lbs.)



18 mm (11/16") 1.4 J AVT Rotary Hammer, SDS-PLUS, LED Job Light

HR1841F

Continuous rating Input	470W
Blows per minute	0 - 4,800 min ⁻¹
No load speed	0 - 2,100 min ⁻¹
Capacity	Concrete: 18 mm (11/16") Masonry: 18 mm (11/16") Steel: 13 mm (1/2") Wood: 24 mm (15/16")
Impact energy	1.4 J
Dimensions (L x W x H)	285 x 75 x 208 mm (11-1/4 x 3 x 8-3/16")
Net weight	2 - 2.5 kg (4.5 - 5.4 lbs.)



18 mm (11/16") 1.4 J Rotary Hammer, SDS-PLUS

HR1840

Continuous rating Input	470W
Blows per minute	0 - 4,800 min ⁻¹
No load speed	0 - 2,100 min ⁻¹
Capacity	Concrete: 18 mm (11/16") Masonry: 18 mm (11/16") Steel: 13 mm (1/2") Wood: 24 mm (15/16")
Impact energy	1.4 J
Dimensions (L x W x H)	285 x 75 x 208 mm (11-1/4 x 3 x 8-3/16")
Net weight	2 - 2.4 kg (4.3 - 5.3 lbs.)



Compatibility list between Model and Drill Bit

Adapted for SDS-MAX bits

Adapted for SDS-PLUS bits











































Compatible size range of TCT Drill BitRecommended size range of Drill BitCompatible size range of Core Bit

Capacity	Bit	Model No.	Battery	[cm]																		
				0	5	10	15	20	25	30	40	50	60	70	80	90	100	110	120	130	140	150
14 mm		HR140D	12V max			3.2-14		3.2-10														Diamond Core Bit/Core Bit not recommended
16 mm		HR166D	12V max			3.2-16		3.2-10														Diamond Core Bit/Core Bit not recommended
16 mm		DHR165	18V			3.2-16		3.2-10		35												Diamond Core Bit (Dry Type): 32 mm
17 mm		DHR171	18V			3.2-17		3.2-10														Diamond Core Bit/Core Bit not recommended
18 mm		DHR182	18V			3.2-18		3.2-10		35												Diamond Core Bit (Dry Type): 32 mm
18 mm		DHR183	18V			3.2-18		3.2-10														Diamond Core Bit/Core Bit not recommended
20 mm		DHR202	18V			3.2-20		4-12		35-54												Diamond Core Bit (Dry Type): 32 mm
20 mm		DHR241	18V			3.2-20		4-12		35-54												Diamond Core Bit (Dry Type): 32 mm
20 mm		HR010G	40V max			3.2-20		3.2-12		35												Diamond Core Bit (Dry Type): 32 mm
24 mm		DHR243 / DHR242	18V			3.2-24		4-16		35-54												Diamond Core Bit (Dry Type): 32~65 mm
26 mm		DHR264 / DHR263	18V x2			3.2-26		4-18		35-54												Diamond Core Bit (Dry Type): 32~65 mm
28 mm		DHR283 / DHR282 / DHR281 / DHR280	18V x2			3.2-28		6-20		35-54												Diamond Core Bit (Dry Type): 32~65 mm
28 mm		HR011G / HR012G	40V max			3.2-28		6-20		35-68												Diamond Core Bit (Dry Type): 32~80 mm
28 mm		HR007G	40V max			3.2-28		6-20		35-54												Diamond Core Bit (Dry Type): 32~65 mm
30 mm		HR009G / HR008G	40V max			6-30		8-22		35-80												Diamond Core Bit (Dry Type): 32~80 mm
40 mm		DHR400	18V x2			10-40		16-35		20-105												
40 mm		HR005G	40V max			10-40		16-35		20-105												
52 mm		HR006G	40V max x2			19-52		25-45		20-160												

Compatibility list between Model and Drill Bit

	Adapted for SDS-MAX bits	 Compatible size range of TCT Drill Bit  Recommended size range of Drill Bit  Compatible size range of Core Bit
	Adapted for SDS-PLUS bits	

Hammer drilling / Chiselling

Capacity	Bit	Model No.	Powered	[cm]																
				0	5	10	15	20	25	30	40	50	60	70	80	90	100	110	120	130
18 mm		HR1841F / HR1840 	AC	3.2-18					3.2-10					35						Diamond Core Bit (Dry Type): 32~65 mm
22 mm		HR2230 	AC	3.2-22					4-14					35-54						Diamond Core Bit (Dry Type): 32~65 mm
23 mm		HR2320T 	AC	3.2-23					4-15					35-68						Diamond Core Bit (Dry Type): 32~70 mm
23 mm		HR2300 	AC	3.2-23					4-15					35-68						Diamond Core Bit (Dry Type): 32~70 mm
24 mm		HR2475 	AC	3.2-24					4-16					35-54						Diamond Core Bit (Dry Type): 32~65 mm
26 mm		HR2641 	AC	3.2-26					4-18					35-68						Diamond Core Bit (Dry Type): 32~80 mm
26 mm		HR2631FT / HR2631F 	AC	3.2-26					4-18					35-68						Diamond Core Bit (Dry Type): 32~80 mm
26 mm		HR2600 / HR2601 	AC	3.2-26					4-18					35-68						Diamond Core Bit (Dry Type): 32~80 mm
26 mm		HR2653T / HR2653 / HR2652 / HR2663 	AC	3.2-26					4-18					35-68						Diamond Core Bit (Dry Type): 32~80 mm
26 mm		HR2670FT / HR2670 	AC	3.2-26					4-18					35-68						Diamond Core Bit (Dry Type): 32~80 mm
28 mm		HR2811FT / HR2811F / HR2810T / HR2810 / HR2800 	AC	3.2-28					6-20					35-80						Diamond Core Bit (Dry Type): 32~80 mm
30 mm		HR3012FC / HR3011FC / HR3001C 	AC	6-30					8-22					35-80						Diamond Core Bit (Dry Type): 32~80 mm
32 mm		HR3210FCT / HR3210C / HR3200C 	AC	4-32					10-20					35-90						Diamond Core Bit (Dry Type): 32~90 mm
35 mm		HR3530 	AC	10-35					12-25					25-105						
35 mm		HR3541FC / HR3540C 	AC	10-35					10-22					25-90						
40 mm		HR4041C 	AC	10-40					22-35					25-118						
40 mm		HR4030C 	AC	10-40					22-35					25-118						
40 mm		HR4013C / HR4003C 	AC	10-40					16-35					20-105						
40 mm		HR4002 	AC	10-40					16-32					20-105						
45 mm		HR4511C / HR4510C / HR4501C 	AC	10-45					22-40					20-125						
52 mm		HR5212C / HR5202C 	AC	19-52					25-45					20-160						

Comparison List

Model No.	Powered	Capacity / Concrete	Impact energy	Type	Net weight	AVT	Soft No load	Built-in Job Light	Quick change
Cordless Rotary Hammer / Cordless Combination Hammer									
SDS-MAX Shank									
HR006G	40Vmax x2	52 mm	21.4 J	Rotary	12.9 - 15.5 kg (28.4 - 34.2 lbs.)	●	●	●	-
HR005G	40Vmax	40 mm	8 J	Rotary	7.4 - 8.8 kg (16.3 - 19.4 lbs.)	●	●	●	-
DHR400	18V x2	40 mm	8 J	Rotary	7.3 - 8.1 kg (16.1 - 17.9 lbs.)	●	●	●	-
SDS-PLUS Shank									
HR009G	40Vmax	30 mm	3.9 J	Combination	5.3 - 6.7 kg (11.7 - 14.8 lbs.)	●	-	●	●
HR008G	40Vmax	30 mm	3.9 J	Combination	5.2 - 6.8 kg (11.5 - 15.0 lbs.)	●	-	●	-
HR012G	40Vmax	28 mm	3.3 J	Combination	4.0 - 5.4 kg (8.8 - 11.9 lbs.)	●	-	●	●
HR011G	40Vmax	28 mm	3.3 J	Combination	3.8 - 5.5 kg (8.4 - 12.1 lbs.)	●	-	●	-
HR007G	40Vmax	28 mm	3 J	Combination	3.8 - 4.8 kg (8.4 - 10.6 lbs.)	●	-	●	-
HR010G	40Vmax	20 mm	2.1 J	Combination	2.8 - 4.5 kg (6.2 - 9.9 lbs.)	●	-	●	-
DHR283	18V x2	28 mm	2.9 J	Combination	4.0 - 4.9 kg (8.8 - 10.8 lbs.)	●	●	●	●
DHR282	18V x2	28 mm	2.8 J	Combination	3.9 - 5.0 kg (8.6 - 11.0 lbs.)	●	●	●	-
DHR281	18V x2	28 mm	2.9 J	Combination	4.0 - 4.9 kg (8.8 - 10.8 lbs.)	●	●	●	●
DHR280	18V x2	28 mm	2.8 J	Combination	3.8 - 4.9 kg (8.4 - 10.8 lbs.)	●	●	●	-
DHR264	18V x2	26 mm	2.5 J	Combination	4.2 - 5.1 kg (9.2 - 11.2 lbs.)	-	-	●	●
DHR263	18V x2	26 mm	2.5 J	Combination	4.1 - 5.1 kg (9 - 11.3 lbs.)	-	-	●	-
DHR243	18V	24 mm	2 J	Combination	3.2 - 3.7 kg (6.9 - 8.3 lbs.)	-	-	-	●
DHR242	18V	24 mm	2 J	Combination	3.1 - 3.8 kg (6.7 - 8.4 lbs.)	-	-	-	-
DHR241	18V	20 mm	2 J	Combination	3.2 - 4 kg (7.1 - 8.8 lbs.)	-	-	-	-
DHR202	18V	20 mm	1.9 J	Combination	3.2 - 4 kg (7.1 - 8.8 lbs.)	-	-	●	-
DHR183	18V	18 mm	1.7 J	Rotary	2.9 kg (6.4 lbs.)	●	-	●	-
DHR182	18V	18 mm	1.7 J	Combination	2.7 kg (6.0 lbs.)	●	-	●	-
DHR171	18V	17 mm	1.2 J	Rotary	2.1 - 2.8 kg (4.6 - 6.2 lbs.)	-	-	●	-
DHR165	18V	16 mm	1.3 J	Rotary	2.3 - 3 kg (5 - 6.6 lbs.)	-	-	●	-
HR166D	12Vmax	16 mm	1.1 J	Rotary	1.8 - 2.0 kg (4.0 - 4.4 lbs.)	-	-	●	-
HR140D	12Vmax	14 mm	1 J	Rotary	1.9 - 2.6 kg (4.3 - 5.6 lbs.)	-	-	●	-

Comparison List

Model No.	Capacity	Continuous rating Input	Impact energy	Type	Net weight	AVT	Soft No load	Built-in Job Light	Quick change
Rotary Hammer / Combination Hammer									
SDS-MAX Shank									
HR5212C	52 mm	1,510 W	19.1 J	Rotary	11.9 kg (26.2 lbs.)	●	●	-	-
HR5202C	52 mm	1,510 W	20 J	Rotary	10.9 - 11.1 kg (24.1 - 24.4 lbs.)	-	-	-	-
HR4511C	45 mm	1,350 W	9.4 J	Rotary	9.0 - 9.1 kg (19.8 - 20.1 lbs.)	●	-	-	-
HR4510C	45 mm	1,350 W	9.4 J	Rotary	8.9 - 9.0 kg (19.5 - 19.9 lbs.)	●	-	-	-
HR4501C	45 mm	1,350 W	10.1 J	Rotary	8.2 - 8.4 kg (18.1 - 18.5 lbs.)	-	-	-	-
HR4003C	40 mm	1,100 W	8.3 J	Rotary	6.2 - 6.4 kg (13.7 - 14.1 lbs.)	-	-	-	-
HR4013C	40 mm	1,100 W	8 J	Rotary	6.8 kg (14.9 lbs.)	●	●	-	-
HR4002	40 mm	1,050 W	6.1 J	Rotary	6.6 - 6.8 kg (14.6 - 15.0 lbs.)	-	-	-	-
HR3541FC	35 mm	850 W	5.7 J	Combination	5.6 kg (12.3 lbs.)	●	-	●	-
HR3540C	35 mm	850 W	5.6 J	Combination	5.2 - 5.3 kg (11.4 - 11.6 lbs.)	-	-	-	-
SDS-PLUS Shank									
HR3210FCT	32 mm	850 W	4.9 J	Combination	5.4 - 5.6 kg (11.9 - 12.3 lbs.)	●	-	●	●
HR3210C	32 mm	850 W	5 J	Combination	5.2 - 5.6 kg (11.4 - 12.4 lbs.)	●	-	-	-
HR3200C	32 mm	850 W	5.1 J	Combination	4.8 - 5.2 kg (10.5 - 11.5 lbs.)	-	-	-	-
HR3012FC	30 mm	1,050 W	3.9 J	Combination	4.5 - 4.7 kg (9.9 - 10.4 lbs.)	●	-	●	●
HR3011FC	30 mm	1,050 W	3.9 J	Combination	4.4 - 4.8 kg (9.7 - 10.6 lbs.)	●	-	●	-
HR3001C	30 mm	1,050 W	3.9 J	Combination	4.1 - 4.5 kg (9.0 - 9.9 lbs.)	-	-	-	-
HR2811FT	28 mm	800 W	2.9 J	Combination	3.6 - 3.9 kg (8.0 - 8.6 lbs.)	-	-	●	●
HR2811F	28 mm	800 W	2.8 J	Combination	3.5 - 3.9 kg (7.7 - 8.7 lbs.)	-	-	●	-
HR2810T	28 mm	800 W	2.9 J	Combination	3.5 - 3.8 kg (7.8 - 8.4 lbs.)	-	-	-	●
HR2810	28 mm	800 W	2.8 J	Combination	3.4 - 3.8 kg (7.5 - 8.5 lbs.)	-	-	-	-
HR2800	28 mm	800 W	2.8 J	Rotary	3.4 - 3.8 kg (7.4 - 8.4 lbs.)	-	-	-	-
HR2670FT	26 mm	800 W	3.0 J	Combination	3.1 - 3.3 kg (6.8 - 7.3 lbs.)	-	-	●	●
HR2670	26 mm	800 W	3.0 J	Combination	2.9 - 3.4 kg (6.4 - 7.5 lbs.)	-	-	-	-
HR2641(D handle)	26 mm	800 W	2.4 J	Combination	3.1 - 3.5 kg (6.8 - 7.7 lbs.)	●	-	-	-
HR2631FT	26 mm	800 W	2.4 J	Combination	3.1 kg (6.8 lbs.)	●	-	●	●
HR2631F	26 mm	800 W	2.4 J	Combination	2.9 kg (6.4 lbs.)	●	-	●	-
HR2601	26 mm	800 W	2.4 J	Rotary	3.1 - 3.6 kg (6.9 - 7.8 lbs.)	●	-	-	-
HR2600	26 mm	800 W	2.4 J	Rotary	2.8 kg (6.2 lbs.)	-	-	-	-
HR2653T	26 mm	800 W	2.2 J	Combination	3.2 - 4.5 kg (7.2 - 9.9 lbs.)	●	-	-	●
HR2653	26 mm	800 W	2.2 J	Combination	3.1 - 4.3 kg (6.9 - 9.6 lbs.)	●	-	-	-
HR2652	26 mm	800 W	2.2 J	Combination	3.0 - 4.3 kg (6.7 - 9.4 lbs.)	-	-	-	-
HR2663(D handle)	26 mm	800 W	2.2 J	Combination	3.3 - 4.6 kg (7.3 - 10.0 lbs.)	●	-	-	-
HR2475(D handle)	24 mm	780 W	2.3 J	Combination	3.0 - 3.4 kg (6.6 - 7.5 lbs.)	-	-	-	-
HR2320T	23 mm	720 W	2.3 J	Combination	2.9 - 3.2 kg (6.4 - 7.0 lbs.)	-	-	-	●
HR2300	23 mm	720 W	2.3 J	Rotary	2.7 kg (5.9 lbs.)	-	-	-	-
HR2230	22 mm	710 W	2.2 J	Rotary	2.6 - 3.1 kg (5.8 - 6.8 lbs.)	-	-	-	-
HR1841F / HR1840	18 mm	470 W	1.4 J	Rotary	2 - 2.5 kg (4.5 - 5.4 lbs.) / 2 - 2.4 kg (4.3 - 5.3 lbs.)	● / -	-	● / -	-
17mm Hex Shank									
HR4030C	40 mm	1,100 W	-	Rotary	6.9 kg (15.2 lbs.)	-	-	-	-
HR3530	35 mm	1,010 W	-	Rotary	5.8 kg (12.8 lbs.)	-	-	-	-
Splines Shank									
HR4041C	40 mm	1,100 W	-	Rotary	6.7 kg (14.8 lbs.)	-	-	-	-

Hammer drilling/Chiselling

40Vmax X2 (80Vmax) XGT BL AWS AVT SOFT NO LOAD 20.9 J Demolition Hammer, SDS-MAX, Twin LED lights

HM002G

40V max x2



Blows per minute	950 - 1,900 min ⁻¹
Impact energy	20.9 J
Shank diameter	18 mm (11/16")
Dimensions (L x W x H)	574 x 146 x 324 mm (22-5/8 x 5-3/4 x 12-3/4")
Net weight	12.0 - 14.5 kg (26.5 - 32.0 lbs.)

XGT BL AWS AVT SOFT NO LOAD XPT



40Vmax XGT BL AWS AVT SOFT NO LOAD 9.4 J Cordless Demolition Hammer, SDS-MAX, Twin LED lights

HM001G

40V max



Blows per minute	0 - 2,650 min ⁻¹
Impact energy	9.4 J
Shank diameter	18 mm (11/16")
Dimensions (L x W x H)	w/ BL4050F: 516 x 113 x 280 mm (20-1/4 x 4-7/16 x 11")
Net weight	6.3 - 7.7 kg (13.9 - 17.0 lbs.)

XGT BL AWS AVT SOFT NO LOAD XPT



21.7 J Demolition Hammer, 30 mm Hex Shank

HM1306



Continuous rating	1,510W
Input	
Blows per minute	1,450 min ⁻¹
Impact energy	21.7 J
Dimensions (L x W x H)	652 x 121 x 231 mm (25-3/4 x 4-3/4 x 9-1/8")
Net weight	15.1 kg (33.3 lbs.)



19.9 J AVT SOFT NO LOAD Demolition Hammer, SDS-MAX

HM1214C



Continuous rating	1,510W
Input	
Blows per minute	950 - 1,900 min ⁻¹
Impact energy	19.9 J
Dimensions (L x W x H)	700 x 129 x 265 mm (27-1/2 x 5-1/8 x 10-3/8")
Net weight	12.3 kg (27.1 lbs.)

AVT SOFT NO LOAD



19.1 J Demolition Hammer, SDS-MAX

HM1205C



Continuous rating	1,510W
Input	
Blows per minute	950 - 1,900 min ⁻¹
Impact energy	19.1 J
Dimensions (L x W x H)	576 x 128 x 265 mm (22-3/4 x 5 x 10-3/8")
Net weight	9.7 kg (21.5 lbs.)



19.1 J Demolition Hammer, SDS-MAX

HM1203C



Continuous rating	1,510W
Input	
Blows per minute	950 - 1,900 min ⁻¹
Impact energy	19.1 J
Dimensions (L x W x H)	576 x 128 x 265 mm (22-3/4 x 5 x 10-3/8")
Net weight	9.7 kg (21.5 lbs.)



18.6 J AVT SOFT NO LOAD Demolition Hammer, SDS-MAX

HM1213C



Continuous rating	1,510W
Input	
Blows per minute	950 - 1,900 min ⁻¹
Impact energy	18.6 J
Dimensions (L x W x H)	576 x 149 x 265 mm (22-3/4 x 5-7/8 x 10-3/8")
Net weight	10.8 kg (23.8 lbs.)

AVT SOFT NO LOAD



12.4 J Demolition Hammer, 21 mm Hex Shank

HM1201



Continuous rating	1,130W
Input	
Blows per minute	2,000 min ⁻¹
Impact energy	12.4 J
Overall length	480 mm (18-7/8")
Net weight	9.1 kg (20.1 lbs.)



11.5 J Demolition Hammer, SDS-MAX

HM1101C



Continuous rating	1,300W
Input	
Blows per minute	1,100 - 2,650 min ⁻¹
Impact energy	11.5 J
Dimensions (L x W x H)	528 x 115 x 247 mm (20-3/4 x 4-1/2 x 9-3/4")
Net weight	7.2 - 7.3 kg (15.8 - 16.1 lbs.)



11.2 J AVT SOFT NO LOAD Demolition Hammer, SDS-MAX

HM1111C



Continuous rating	1,300W
Input	
Blows per minute	1,100 - 2,650 min ⁻¹
Impact energy	11.2 J
Dimensions (L x W x H)	528 x 126 x 247 mm (20-3/4 x 5 x 9-3/4")
Net weight	7.8 - 8.0 kg (17.3 - 17.6 lbs.)

AVT SOFT NO LOAD



Hammer drilling/Chiselling

7.2 J Demolition Hammer, 17 mm Hex Shank

HM0830

Continuous rating	1,010W
Input	
Blows per minute	2,700 min ⁻¹
Impact energy	7.2 J
Dimensions (L x W x H)	390 x 98 x 209 mm (15-3/8 x 3-7/8 x 8-1/4")
Net weight	4.9 kg (10.7 lbs.)



8.1 J AVT SOFT NO LOAD Demolition Hammer, SDS-MAX

HM0871C

Continuous rating	1,100W
Input	
Blows per minute	1,100 - 2,650 min ⁻¹
Impact energy	8.1 J
Dimensions (L x W x H)	466 x 116 x 230 mm (18-3/8 x 4-9/16 x 9")
Net weight	5.6 - 5.8 kg (12.4 - 12.8 lbs.)



AVT SOFT NO LOAD



7.6 J Demolition Hammer, SDS-MAX

HM0870C

Continuous rating	1,100W
Input	
Blows per minute	1,100 - 2,650 min ⁻¹
Impact energy	7.6 J
Dimensions (L x W x H)	449 x 109 x 230 mm (17-3/4 x 4-1/4 x 9")
Net weight	5.1 - 5.3 kg (11.1 - 11.6 lbs.)



7.2 J Demolition Hammer, 17 mm Hex Shank

HM0810

Continuous rating	900W
Input	
Blows per minute	2,900 min ⁻¹
Impact energy	7.2 J
Overall length	410 mm (16-1/8")
Net weight	6.2 kg (13.7 lbs.)



7.2 J Demolition Hammer, Sliding Chuck, 17 mm Hex shank

HM0810T

Continuous rating	900W
Input	
Blows per minute	2,900 min ⁻¹
Impact energy	7.2 J
Overall length	428 mm (16-7/8")
Net weight	6.3 kg (13.9 lbs.)



5.3 J Demolition Hammer, 19 mm Hex Shank

HM0810B

Continuous rating	900W
Input	
Blows per minute	2,900 min ⁻¹
Impact energy	5.3 J
Overall length	423 mm (16-5/8")
Net weight	6.6 kg (14.5 lbs.)



40Vmax x2 (80Vmax) XGT BL AWS AVT SOFT NO LOAD, 72.8 J Cordless Breaker, 28.6 mm Hex Shank

HM004G

Blows per minute	870 min ⁻¹
Shank type	Hex 28.6 (1-1/8)
Impact energy	72.8 J (53.7 ft.lbs.)
Dimensions (L x W x H)	882 x 227 x 540 mm (34-3/4 x 8-15/16 x 21-1/4")
Net weight	29.6 - 32.1 kg (65.3 - 70.8 lbs.)

40V max x2



XGT BL AVT AWS SOFT NO LOAD XPT



72.8 J AVT SOFT NO LOAD Electric Breaker, 28.6 mm Hex Shank

HM1812

Continuous rating	2,000W
Input	
Blows per minute	870 min ⁻¹
Impact energy	72.8 J
Shank diameter	28.6 mm (1-1/8")
Dimensions (L x W x H)	843 x 210 x 608 mm (33-1/4 x 8-1/4 x 24")
Net weight	31.3 kg (69 lbs.)



AVT SOFT NO LOAD



71.4 J Electric Breaker, 28.6 mm Hex Shank

HM1802

Continuous rating	2,000W
Input	
Blows per minute	870 min ⁻¹
Impact energy	71.4 J
Dimensions (L x W x H)	843 x 210 x 608 mm (33-1/4 x 8-1/4 x 24")
Net weight	29.4 kg (64.8 lbs.)



AVT



48.9 J AVT SOFT NO LOAD Electric Breaker, 30 mm Hex Shank

HM1511

Continuous rating	1,850W
Input	
Blows per minute	1,300 min ⁻¹
Impact energy	48.9 J
Dimensions (L x W x H)	781 x 130 x 266 mm (30-3/4 x 5-1/8 x 10-1/2")
Net weight	19.2 kg (42.3 lbs.)



AVT SOFT NO LOAD



48.1 J Electric Breaker, 30 mm Hex Shank

HM1501

Continuous rating	1,850W
Input	
Blows per minute	1,300 min ⁻¹
Impact energy	48.1 J
Dimensions (L x W x H)	781 x 130 x 266 mm (30-3/4 x 5-1/8 x 10-1/2")
Net weight	18.4 kg (40.6 lbs.)



48.5 J AVT SOFT NO LOAD Electric Breaker, 28.6 mm Hex Shank

HM1512

Continuous rating	1,850W
Input	
Blows per minute	1,300 min ⁻¹
Impact energy	48.5 J
Dimensions (L x W x H)	809 x 130 x 266 mm (31-3/4 x 5-1/8 x 10-1/2")
Net weight	20.4 kg (45.0 lbs.)



49.1 J Electric Breaker, 28.6 mm Hex Shank

HM1502

Continuous rating	1,850W
Input	
Blows per minute	1,300 min ⁻¹
Impact energy	49.1 J
Dimensions (L x W x H)	809 x 130 x 266 mm (31-3/4 x 5-1/8 x 10-1/2")
Net weight	19.7 kg (43.4 lbs.)



25.0 J AVT SOFT NO LOAD Electric Breaker, 30 mm Hex Shank

HM1317C

Continuous rating	1,510W
Input	
Blows per minute	730 - 1,450 min ⁻¹
Impact energy	High Pressure: 25.0 J / Low Pressure: 21.0 J
Dimensions (L x W x H)	715 x 129 x 266 mm (28-1/8 x 5-1/8 x 10-1/2")
Net weight	17.8 kg (39.2 lbs.)



25.5 J Electric Breaker, 30 mm Hex Shank

HM1307C

Continuous rating	1,510W
Input	
Blows per minute	730 - 1,450 min ⁻¹
Impact energy	High Pressure: 25.5 J
Dimensions (L x W x H)	715 x 129 x 266 mm (28-1/8 x 5-1/8 x 10-1/2")
Net weight	16.1 kg (35.5 lbs.)



26.2 J AVT SOFT NO LOAD Electric Breaker, 28.6 mm Hex Shank

HM1317CB

Continuous rating	1,510W
Input	
Blows per minute	730 - 1,450 min ⁻¹
Impact energy	High Pressure: 26.5 J / Low Pressure: 24.0 J
Dimensions (L x W x H)	824 x 129 x 266 mm (32-1/2 x 5-1/8 x 10-1/2")
Net weight	19.7 kg (43.4 lbs.)



23.6 J Electric Breaker, 28.6 mm Hex Shank

HM1307CB

Continuous rating	1,510W
Input	
Blows per minute	730 - 1,450 min ⁻¹
Impact energy	High Pressure: 23.6 J
Dimensions (L x W x H)	824 x 129 x 266 mm (32-1/2 x 5-1/8 x 10-1/2")
Net weight	18.1 kg (39.9 lbs.)



18V LXT BL AVT Cordless Power Scraper, SDS-PLUS, Twin LED lights

DHK180

18V

Blows per minute	0 - 3,200 min ⁻¹
Impact energy	3.1 J
Continuous use	w/ BL1860B: 21 min.
Dimensions (L x W x H)	w/ BL1830B / BL1840B / BL1850B / BL1860B: 368 x 99 x 211 mm (14-1/2 x 3-7/8 x 8-5/16")
Net weight	3.3 - 3.6 kg (7.3 - 7.9 lbs.)



1.8 J Power Scraper, SDS-PLUS

HK0500

Continuous rating	550W
Input	
Blows per minute	2,000 - 3,500 min ⁻¹
Impact energy	1.8 J
Overall length	468 mm (18-7/16")
Net weight	3.2 kg (11 lbs.)



3.1 J Power Scraper, SDS-PLUS

HK1820

Continuous rating	550W
Input	
Blows per minute	0 - 3,200 min ⁻¹
Impact energy	3.1 J
Dimensions (L x W x H)	351 x 102 x 203 mm (13-3/4 x 4 x 8")
Net weight	3.4 kg (7.5 lbs.)



Hammer drilling/Chiselling

2.4 J Power Scraper, Makita Small Shank

HK1810



Continuous rating Input	505W
Blows per minute	0 - 3,200 min ⁻¹
Impact energy	2.4 J
Overall length	315 mm (12-3/8")
Net weight	3.2 kg (7.1 lbs.)



20 mm (3/4") 1,010 W 2-Speed Hammer Drill with Keyless Chuck

HP2071F



Continuous rating Input	1,010W
Impacts per minute	High: 0 - 58,000 min ⁻¹ Low: 0 - 24,000 min ⁻¹
No load speed	High: 0 - 2,900 min ⁻¹ Low: 0 - 1,200 min ⁻¹
Capacity	Concrete: 20 mm (3/4") Steel, Hi: 8 mm (5/16") Steel, Lo: 16 mm (5/8") Wood, Hi: 25 mm (1") Wood, Lo: 40 mm (1-9/16") Wood (Self-feed bit): 120 mm (4-3/4")
Chuck capacity	2.0 - 13 mm (1/16 - 1/2")
Overall length	362 mm (14-1/4")
Net weight	2.6 kg (5.7 lbs.)



20 mm (3/4") 1,010 W 2-Speed Hammer Drill with Keyless Chuck

HP2071



Continuous rating Input	1,010W
Impacts per minute	High: 0 - 58,000 min ⁻¹ Low: 0 - 24,000 min ⁻¹
No load speed	High: 0 - 2,900 min ⁻¹ Low: 0 - 1,200 min ⁻¹
Capacity	Concrete: 20 mm (3/4") Steel, Hi: 8 mm (5/16") Steel, Lo: 16 mm (5/8") Wood, Hi: 25 mm (1") Wood, Lo: 40 mm (1-9/16") Wood (Self-feed bit): 120 mm (4-3/4")
Chuck capacity	2.0 - 13 mm (1/16 - 1/2")
Overall length	362 mm (14-1/4")
Net weight	2.6 kg (5.7 lbs.)



20 mm (3/4") 1,010 W 2-Speed Hammer Drill with Keyed Chuck, LED Job Light

HP2070F



Continuous rating Input	1,010W
Impacts per minute	High: 0 - 58,000 min ⁻¹ Low: 0 - 24,000 min ⁻¹
No load speed	High: 0 - 2,900 min ⁻¹ Low: 0 - 1,200 min ⁻¹
Capacity	Concrete: 20 mm (3/4") Steel, Hi: 8 mm (5/16") Steel, Lo: 16 mm (5/8") Wood, Hi: 25 mm (1") Wood, Lo: 40 mm (1-9/16") Wood (Self-feed bit): 120 mm (4-3/4")
Chuck capacity	2.0 - 13 mm (1/16 - 1/2")
Overall length	364 mm (14-3/8")
Net weight	2.6 kg (5.7 lbs.)



20 mm (3/4") 1,010 W 2-Speed Hammer Drill with Keyed Chuck

HP2070



Continuous rating Input	1,010W
Impacts per minute	High: 0 - 58,000 min ⁻¹ Low: 0 - 24,000 min ⁻¹
No load speed	High: 0 - 2,900 min ⁻¹ Low: 0 - 1,200 min ⁻¹
Capacity	Concrete: 20 mm (3/4") Steel, Hi: 8 mm (5/16") Steel, Lo: 16 mm (5/8") Wood, Hi: 25 mm (1") Wood, Lo: 40 mm (1-9/16") Wood (Self-feed bit): 120 mm (4-3/4")
Chuck capacity	2.0 - 13 mm (1/16 - 1/2")
Overall length	364 mm (14-3/8")
Net weight	2.6 kg (5.7 lbs.)



20 mm (3/4") 720 W 2-Speed Hammer Drill with Keyless Chuck, LED Job Light

HP2051F



Continuous rating Input	720W
Impacts per minute	High: 0 - 58,000 min ⁻¹ Low: 0 - 24,000 min ⁻¹
No load speed	High: 0 - 2,900 min ⁻¹ Low: 0 - 1,200 min ⁻¹
Capacity	Concrete: 20 mm (3/4") Steel, Hi: 8 mm (5/16") Steel, Lo: 13 mm (1/2") Wood, Hi: 25 mm (1") Wood, Lo: 40 mm (1-9/16") Wood (Self-feed bit): 90 mm (3-1/2")
Chuck capacity	1.5 - 13 mm (1/16 - 1/2")
Overall length	360 mm (14-1/8")
Net weight	2.5 kg (5.6 lbs.)



20 mm (3/4") 720 W 2-Speed Hammer Drill with Keyless Chuck

HP2051



Continuous rating Input	720W
Impacts per minute	High: 0 - 58,000 min ⁻¹ Low: 0 - 24,000 min ⁻¹
No load speed	High: 0 - 2,900 min ⁻¹ Low: 0 - 1,200 min ⁻¹
Capacity	Concrete: 20 mm (3/4") Steel, Hi: 8 mm (5/16") Steel, Lo: 13 mm (1/2") Wood, Hi: 25 mm (1") Wood, Lo: 40 mm (1-9/16") Wood (Self-feed bit): 90 mm (3-1/2")
Chuck capacity	1.5 - 13 mm (1/16 - 1/2")
Overall length	360 mm (14-1/8")
Net weight	2.5 kg (5.6 lbs.)



20 mm (3/4") 720 W 2-Speed Hammer Drill with Keyed Chuck, LED Job Light

HP2050F



Continuous rating Input	720W
Impacts per minute	High: 0 - 58,000 min ⁻¹ Low: 0 - 24,000 min ⁻¹
No load speed	High: 0 - 2,900 min ⁻¹ Low: 0 - 1,200 min ⁻¹
Capacity	Concrete: 20 mm (3/4") Steel, Hi: 8 mm (5/16") Steel, Lo: 13 mm (1/2") Wood, Hi: 25 mm (1") Wood, Lo: 40 mm (1-9/16") Wood (Self-feed bit): 90 mm (3-1/2")
Chuck capacity	1.5 - 13 mm (1/16 - 1/2")
Overall length	362 mm (14-1/4")
Net weight	2.5 kg (5.6 lbs.)



20 mm (3/4") 720 W 2-Speed Hammer Drill with Keyed Chuck

HP2050



Continuous rating Input	720W
Impacts per minute	High: 0 - 58,000 min ⁻¹ Low: 0 - 24,000 min ⁻¹
No load speed	High: 0 - 2,900 min ⁻¹ Low: 0 - 1,200 min ⁻¹
Capacity	Concrete: 20 mm (3/4") Steel, Hi: 8 mm (5/16") Steel, Lo: 13 mm (1/2") Wood, Hi: 25 mm (1") Wood, Lo: 40 mm (1-9/16") Wood (Self-feed bit): 90 mm (3-1/2")
Chuck capacity	1.5 - 13 mm (1/16 - 1/2")
Overall length	362 mm (14-1/4")
Net weight	2.5 kg (5.6 lbs.)



16 mm (5/8") 710 W Hammer Drill with Keyless Chuck

HP1631



Continuous rating Input	710W
Blows per minute	0 - 48,000 min ⁻¹
No load speed	0 - 3,200 min ⁻¹
Capacity	Concrete: 16 mm (5/8") Masonry: 16 mm (5/8") Steel: 13 mm (1/2") Wood: 30 mm (1-3/16") Wood (Self-feed bit): 60 mm (2-3/8")
Chuck capacity	1.5 - 13 mm (1/16 - 1/2")
Dimensions (L x W x H)	296 x 75 x 204 mm (11-5/8 x 2-15/16 x 8")
Net weight	2 kg (4.4 lbs.)



16 mm (5/8") 710 W Hammer Drill with Keyed Chuck

HP1630



Continuous rating Input	710W
Blows per minute	0 - 48,000 min ⁻¹
No load speed	0 - 3,200 min ⁻¹
Capacity	Concrete: 16 mm (5/8") Masonry: 16 mm (5/8") Steel: 13 mm (1/2") Wood: 30 mm (1-3/16") Wood (Self-feed bit): 60 mm (2-3/8")
Chuck capacity	1.5 - 13 mm (1/16 - 1/2")
Dimensions (L x W x H)	296 x 75 x 204 mm (11-5/8 x 2-15/16 x 8")
Net weight	2.1 kg (4.6 lbs.)



16 mm (5/8") 680 W Hammer Drill with Keyless Chuck, LED Job Light

HP1641F



Continuous rating Input	680W
Blows per minute	0 - 44,800 min ⁻¹
No load speed	0 - 2,800 min ⁻¹
Capacity	Concrete: 16 mm (5/8") Masonry: 16 mm (5/8") Steel: 13 mm (1/2") Wood: 30 mm (1-3/16") Wood (Self-feed bit): 60 mm (2-3/8")
Chuck capacity	1.5 - 13 mm (1/16 - 1/2")
Dimensions (L x W x H)	303 x 72 x 222 mm (11-7/8 x 2-13/16 x 8-3/4")
Net weight	2 kg (4.3 lbs.)



16 mm (5/8") 680 W Hammer Drill with Keyless Chuck

HP1641



Continuous rating Input	680W
Blows per minute	0 - 44,800 min ⁻¹
No load speed	0 - 2,800 min ⁻¹
Capacity	Concrete: 16 mm (5/8") Masonry: 16 mm (5/8") Steel: 13 mm (1/2") Wood: 30 mm (1-3/16") Wood (Self-feed bit): 60 mm (2-3/8")
Chuck capacity	1.5 - 13 mm (1/16 - 1/2")
Dimensions (L x W x H)	303 x 72 x 222 mm (11-7/8 x 2-13/16 x 8-3/4")
Net weight	2 kg (4.3 lbs.)



16 mm (5/8") 680 W Hammer Drill with Keyed Chuck

HP1640



Continuous rating Input	680W
Blows per minute	0 - 44,800 min ⁻¹
No load speed	0 - 2,800 min ⁻¹
Capacity	Concrete: 16 mm (5/8") Masonry: 16 mm (5/8") Steel: 13 mm (1/2") Wood: 30 mm (1-3/16") Wood (Self-feed bit): 60 mm (2-3/8")
Chuck capacity	1.5 - 13 mm (1/16 - 1/2")
Dimensions (L x W x H)	303 x 72 x 222 mm (11-7/8 x 2-13/16 x 8-3/4")
Net weight	2 kg (4.4 lbs.)



12 mm (15/32") 400 W Hammer Drill with Keyed Chuck

HP1230



Continuous rating Input	400W
Blows per minute	0 - 31,900 min ⁻¹
No load speed	0 - 2,900 min ⁻¹
Capacity	Concrete: 12 mm (15/32") Masonry: 12 mm (15/32") Steel: 10 mm (3/8") Wood: 15 mm (9/16") Wood (Self-feed bit): 30 mm (1-3/16")
Chuck capacity	1.5 - 10 mm (1/16 - 3/8")
Dimensions (L x W x H)	239 x 67 x 188 mm (9-3/8 x 2-5/8 x 7-3/8")
Net weight	1.7 kg (3.7 lbs.)



152 mm (6") 850 W Diamond Core Hammer Drill

8406



Continuous rating Input	850W
Capacity	Concrete (w/ Diamond core bit): 152 mm (6") Masonry: 20 mm (3/4") Steel: 13 mm (1/2") Wood: 30 mm (1-1/8") Wood (Self-feed bit): 30 mm (1-1/8")
Overall length	400 mm (15-3/4")
Net weight	3.7 kg (8.1 lbs.)



Comparison List

Model No.	Powers	Impact energy	Net weight	AVT	Soft No load
-----------	--------	---------------	------------	-----	--------------

Cordless Breaker

28.6mm Hex Shank

HM004G	40Vmax x2	72.8 J	29.6 - 32.1 kg (65.3 - 70.8 lbs.)	●	●
--------	-----------	--------	-----------------------------------	---	---

Model No.	Powered	Impact energy	Net weight	AVT	Soft No load
-----------	---------	---------------	------------	-----	--------------

Cordless Demolition Hammer

SDS-MAX Shank

HM002G	40Vmax x2	20.9 J	12.0 - 14.5 kg (26.5 - 32.0 lbs.)	●	●
HM001G	40Vmax	9.4 J	6.3 - 7.7 kg (13.9 - 17.0 lbs.)	●	●

Model No.	Continuous rating Input	Impact energy	Net weight	AVT	Soft No load
-----------	-------------------------	---------------	------------	-----	--------------

Demolition Hammer / Electric Breaker

SDS-MAX Shank

HM1214C	1,510 W	19.9 J	12.3 kg (27.1 lbs.)	●	●
HM1205C	1,510 W	19.1 J	9.7 kg (21.5 lbs.)	-	-
HM1203C	1,510 W	19.1 J	9.7 kg (21.5 lbs.)	-	-
HM1213C	1,510 W	18.6 J	10.8 kg (23.8 lbs.)	●	●
HM1101C	1,300 W	11.5 J	7.2 - 7.3 kg (15.8 - 16.1 lbs.)	-	-
HM1111C	1,300 W	11.2 J	7.8 - 8.0 kg (17.3 - 17.6 lbs.)	●	●
HM0871C	1,100 W	8.1 J	5.6 - 5.8 kg (12.4 - 12.8 lbs.)	●	●
HM0870C	1,100 W	7.6 J	5.1 - 5.3 kg (11.1 - 11.6 lbs.)	-	-

30mm Hex Shank

HM1306	1,510 W	21.7 J	15.1 kg (33.3 lbs.)	-	-
HM1317C	1,510 W	25 J	17.8 kg (39.2 lbs.)	●	●
HM1307C	1,510 W	25.5 J	16.1 kg (35.5 lbs.)	-	-
HM1511	1,850 W	48.9 J	19.2 kg (42.3 lbs.)	●	●
HM1501	1,850 W	48.1 J	18.4 kg (40.6 lbs.)	-	-

28.6mm Hex Shank

HM1812	2,000 W	72.8 J	31.3 kg (69 lbs.)	●	●
HM1802	2,000 W	71.4 J	29.4 kg (64.8 lbs.)	-	-
HM1512	1,850 W	48.5 J	20.4 kg (45.0 lbs.)	●	●
HM1502	1,850 W	49.1 J	19.7 kg (43.4 lbs.)	-	-
HM1317CB	1,510 W	26.5 J	19.7 kg (43.4 lbs.)	●	●
HM1307CB	1,510 W	23.6 J	18.1 kg (39.9 lbs.)	-	-

21mm Hex Shank

HM1201	1,130 W	12.4 J	9.1 kg (20.1 lbs.)	-	-
--------	---------	--------	--------------------	---	---

19mm Hex Shank

HM0810B	900 W	5.3 J	6.6 kg (14.5 lbs.)	-	-
---------	-------	-------	--------------------	---	---

17mm Hex Shank

HM0830	1,010 W	7.2 J	4.9 kg (10.7 lbs.)	-	-
HM0810	900 W	7.2 J	6.2 kg (13.7 lbs.)	-	-
HM0810T	900 W	7.2 J	6.3 kg (13.9 lbs.)	-	-

Icon

- Double Insulation
- Variable Speed
- Brake
- Anti-restart function
- Mechanical 2-Speed
- Electronic 2-Speed
- Electronic 3-Speed
- Torque Limiter
- Constant Speed
- Soft Start
- Hook & Loop
- Dust Collection
- Built-in Job Light
- Carrying Case

40Vmax XGT BL AFT Cordless Flat-Head Angle Grinder, Anti-Restart Function, Electric Brake

40V max

new



GA055G:
Slide switch

GA056G:
Paddle switch

XGT BL AFT XPT



	GA055G	GA056G
Wheel diameter	125 mm (5")	125 mm (5")
Minimum access angle	39°	39°
No load speed	3,000 - 9,000 min ⁻¹	3,000 - 9,000 min ⁻¹
Cutting depth	30 mm (1-3/16")	30 mm (1-3/16")
Dimensions (L x W x H)	483 x 140 x 136 mm (19 x 5-1/2 x 5-3/8")	483 x 140 x 136 mm (19 x 5-1/2 x 5-3/8")
Net weight	3.1 - 4.4 kg (6.8 - 9.7 lbs.)	3.1 - 4.4 kg (6.8 - 9.7 lbs.)

40Vmax XGT BL AFT Cordless Angle Grinder, Anti-Restart Function, Electric Brake, Slide Switch Lock-On

40V max



XGT BL AFT XPT



	GA003G	GA004G	GA005G
Wheel diameter	100 mm (4")	115 mm (4-1/2")	125 mm (5")
No load speed	8,500 min ⁻¹	8,500 min ⁻¹	8,500 min ⁻¹
Dimensions (L x W x H)	w/ BL4040: 410 x 117 x 162 mm (16-1/8 x 4-5/8 x 6-3/8")	w/ BL4040: 410 x 130 x 168 mm (16-1/8 x 5-1/8 x 6-5/8")	w/ BL4040: 410 x 140 x 168 mm (16-1/8 x 5-1/2 x 6-5/8")
Net weight	2.8-3.3 kg (6.2-7.3 lbs.)	2.9-3.5 kg (6.4-7.7 lbs.)	2.9-3.6 kg (6.4-7.9 lbs.)

40Vmax XGT BL AFT Cordless Angle Grinder, Anti-Restart Function, Slide Switch Lock-On

40V max



XGT BL AFT XPT



	GA006G	GA007G	GA008G
Wheel diameter	100 mm (4")	115 mm (4-1/2")	125 mm (5")
No load speed	8,500 min ⁻¹	8,500 min ⁻¹	8,500 min ⁻¹
Dimensions (L x W x H)	w/ BL4040: 410 x 117 x 158 mm (16-1/8 x 4-5/8 x 6-1/4")	w/ BL4040: 410 x 130 x 165 mm (16-1/8 x 5-1/8 x 6-1/2")	w/ BL4040: 410 x 140 x 165 mm (16-1/8 x 5-1/2 x 6-1/2")
Net weight	2.7-3.3 kg (6.0-7.3 lbs.)	2.9-3.5 kg (6.4-7.7 lbs.)	2.9-3.5 kg (6.4-7.7 lbs.)

40Vmax XGT BL AFT Cordless Angle Grinder, Anti-Restart Function, Electric Brake, Paddle Switch

40V max



XGT BL AFT XPT



	GA011G	GA012G	GA013G
Wheel diameter	100 mm (4")	115 mm (4-1/2")	125 mm (5")
No load speed	8,500 min ⁻¹	8,500 min ⁻¹	8,500 min ⁻¹
Dimensions (L x W x H)	411 x 117 x 162 mm (16-1/4 x 4-5/8 x 6-3/8")	411 x 130 x 169 mm (16-1/4 x 5-1/8 x 6-5/8")	411 x 140 x 169 mm (16-1/4 x 5-1/2 x 6-5/8")
Net weight	2.8 - 5.2 kg (6.2 - 11.5 lbs.)	2.9 - 5.3 kg (6.4 - 11.7 lbs.)	3.0 - 5.3 kg (6.6 - 11.7 lbs.)

40Vmax XGT BL AFT Cordless Angle Grinder, Anti-Restart Function, Paddle Switch

40V max



XGT BL AFT XPT



	GA014G	GA015G	GA016G
Wheel diameter	100 mm (4")	115 mm (4-1/2")	125 mm (5")
No load speed	8,500 min ⁻¹	8,500 min ⁻¹	8,500 min ⁻¹
Dimensions (L x W x H)	w/ BL4040: 410 x 117 x 158 mm (16-1/8 x 4-5/8 x 6-1/4")	w/ BL4040: 410 x 130 x 165 mm (16-1/8 x 5-1/8 x 6-1/2")	w/ BL4040: 410 x 140 x 165 mm (16-1/8 x 5-1/2 x 6-1/2")
Net weight	2.8-3.3 kg (6.2-7.3 lbs.)	2.9-3.5 kg (6.4-7.7 lbs.)	2.9-3.6 kg (6.4-7.9 lbs.)

Grinding/Sanding/Polishing

40Vmax XGT BL AWS AFT Cordless Angle Grinder, Anti-Restart Function, Electric Brake, Slide Switch Lock-On

40V max



XGT **BL** **AFT** **AWS** **XPT**



	GA021G	GA022G	GA023G
Wheel diameter	100 mm (4")	115 mm (4-1/2")	125 mm (5")
No load speed	3,000 - 8,500 min ⁻¹	3,000 - 8,500 min ⁻¹	3,000 - 8,500 min ⁻¹
Dimensions (L x W x H)	413-425 x 117 x 150-162 mm (16-1/4-16-3/4 x 4-5/8 x 5-7/8-6-3/8")	413-425 x 130 x 156-168 mm (16-1/4-16-3/4 x 5-1/8 x 6-1/8-6-5/8")	413-425 x 140 x 156-168 mm (16-1/4-16-3/4 x 5-1/2 x 6-1/8-6-5/8")
Net weight	2.8 - 3.7 kg (6.2 - 8.2 lbs.)	2.9 - 3.9 kg (6.4 - 8.6 lbs.)	3.0 - 4.7 kg (6.6 - 10.4 lbs.)

40Vmax XGT BL AWS AFT Cordless Angle Grinder, Anti-Restart Function, Slide Switch Lock-On

40V max



XGT **BL** **AFT** **AWS** **XPT**



	GA024G	GA025G	GA026G
Wheel diameter	100 mm (4")	115 mm (4-1/2")	125 mm (5")
No load speed	3,000 - 8,500 min ⁻¹	3,000 - 8,500 min ⁻¹	3,000 - 8,500 min ⁻¹
Dimensions (L x W x H)	w/ BL4040: 425 x 117 x 158 mm (16-3/4 x 4-5/8 x 6-1/4")	w/ BL4040: 425 x 130 x 165 mm (16-3/4 x 5-1/8 x 6-1/2")	w/ BL4040: 425 x 140 x 165 mm (16-3/4 x 5-1/2 x 6-1/2")
Net weight	2.8-3.4 kg (6.2-7.5 lbs.)	2.9-3.5 kg (6.4-7.7 lbs.)	2.9-4.4 kg (6.4-9.7 lbs.)

40Vmax XGT BL AWS AFT Cordless Angle Grinder, Anti-Restart Function, Electric Brake, Paddle Switch

40V max



XGT **BL** **AFT** **AWS** **XPT**



	GA027G	GA028G	GA029G
Wheel diameter	100 mm (4")	115 mm (4-1/2")	125 mm (5")
No load speed	3,000 - 8,500 min ⁻¹	3,000 - 8,500 min ⁻¹	3,000 - 8,500 min ⁻¹
Dimensions (L x W x H)	413-425 x 117 x 150-162 mm (16-1/4-16-3/4 x 4-5/8 x 5-7/8-6-3/8")	413-425 x 130 x 156-168 mm (16-1/4-16-3/4 x 5-1/8 x 6-1/8-6-5/8")	413-425 x 140 x 156-168 mm (16-1/4-16-3/4 x 5-1/2 x 6-1/8-6-5/8")
Net weight	2.8 - 3.7 kg (6.2 - 8.2 lbs.)	3.0 - 3.9 kg (6.6 - 8.6 lbs.)	3.0 - 5.4 kg (6.6 - 11.9 lbs.)

40Vmax XGT BL AWS AFT Cordless 100 mm (4") Angle Grinder, Anti-Restart Function, Paddle Switch

40V max



XGT **BL** **AFT** **AWS** **XPT**



	GA030G
Wheel diameter	100 mm (4")
No load speed	3,000 - 8,500 min ⁻¹
Dimensions (L x W x H)	w/ BL4040: 425 x 117 x 158 mm (16-3/4 x 4-5/8 x 6-1/4")
Net weight	2.8-3.4 kg (6.2-7.5 lbs.)

40Vmax XGT BL AWS AFT Cordless Angle Grinder, Anti-Restart Function, Electric Brake, Slide Switch Lock-On, X-LOCK

40V max



XGT **BL** **AFT** **AWS** **XLOCK** **XPT**



	GA039G	GA040G	GA041G
Wheel diameter	100 mm (4")	115 mm (4-1/2")	125 mm (5")
No load speed	3,000 - 8,500 min ⁻¹	3,000 - 8,500 min ⁻¹	3,000 - 8,500 min ⁻¹
Dimensions (L x W x H)	421-476 x 117 x 149-178 mm (16-1/2-18-3/4 x 4-5/8 x 5-7/8-7")	421-476 x 130 x 151-180 mm (16-1/2-18-3/4 x 5-1/8 x 5-15/16-7-1/8")	421-476 x 140 x 151-180 mm (16-1/2-18-3/4 x 5-1/2 x 5-15/16-7-1/8")
Net weight	3.0 - 5.3 kg (6.6 - 11.7 lbs.)	3.0 - 5.3 kg (6.6 - 11.7 lbs.)	3.0 - 5.3 kg (6.6 - 11.7 lbs.)

40Vmax XGT BL AWS AFT Cordless Angle Grinder, Anti-Restart Function, Electric Brake, Paddle Switch, X-LOCK

40V max



XGT **BL** **AFT** **AWS** **XLOCK** **XPT**



	GA042G	GA043G	GA044G
Wheel diameter	100 mm (4")	115 mm (4-1/2")	125 mm (5")
No load speed	3,000 - 8,500 min ⁻¹	3,000 - 8,500 min ⁻¹	3,000 - 8,500 min ⁻¹
Dimensions (L x W x H)	421-476 x 117 x 149-178 mm (16-1/2-18-3/4 x 4-5/8 x 5-7/8-7")	421-476 x 130 x 151-180 mm (16-1/2-18-3/4 x 5-1/8 x 5-15/16-7-1/8")	421-476 x 140 x 151-180 mm (16-1/2-18-3/4 x 5-1/2 x 5-15/16-7-1/8")
Net weight	3.0 - 5.4 kg (6.6 - 11.9 lbs.)	3.0 - 5.4 kg (6.6 - 11.9 lbs.)	3.0 - 5.4 kg (6.6 - 11.9 lbs.)

40Vmax XGT BL AFT Cordless Angle Grinder, Anti-Restart Function, Electric Brake, Paddle Switch, X-LOCK

40V max



XGT **BL** **AFT** **XLOCK** **XPT**



	GA045G	GA046G	GA047G
Wheel diameter	100 mm (4")	115 mm (4-1/2")	125 mm (5")
No load speed	8,500 min ⁻¹	8,500 min ⁻¹	8,500 min ⁻¹
Dimensions (L x W x H)	406-461 x 117 x 149-178 mm (16-18-1/8 x 4-5/8 x 5-7/8-7")	406-461 x 130 x 151-180 mm (16-18-1/8 x 5-1/8 x 5-15/16-7-1/8")	406-461 x 140 x 151-180 mm (16-18-1/8 x 5-1/2 x 5-15/16-7-1/8")
Net weight	2.9 - 5.3 kg (6.4 - 11.7 lbs.)	3.0 - 5.3 kg (6.6 - 11.7 lbs.)	3.0 - 5.3 kg (6.6 - 11.7 lbs.)

Grinding/Sanding/Polishing

40Vmax XGT BL AFT Cordless Angle Grinder, Anti-Restart Function, Electric Brake, Paddle Switch

40V max



XGT BL AFT XPT



	GA048G	GA049G	GA050G	GA051G
Wheel diameter	100 mm (4")	115 mm (4-1/2")	125 mm (5")	150 mm (6")
No load speed	11,000 min ⁻¹	11,000 min ⁻¹	11,000 min ⁻¹	9,000 min ⁻¹
Dimensions (L x W x H)	398-453 x 117 x 150-179 mm (15-5/8-17-7/8 x 4-5/8 x 5-7/8-7")	398-453 x 130 x 156-185 mm (15-5/8-17-7/8 x 5-1/8 x 6-1/8-7-1/4")	398-453 x 140 x 156-185 mm (15-5/8-17-7/8 x 5-1/2 x 6-1/8-7-1/4")	398-453 x 171 x 156-185 mm (15-5/8-17-7/8 x 6-3/4 x 6-1/8-7-1/4")
Net weight	2.8 - 5.2 kg (6.2 - 11.5 lbs.)	3.0 - 5.4 kg (6.6 - 11.9 lbs.)	3.0 - 5.4 kg (6.6 - 11.9 lbs.)	3.1 - 4.7 kg (6.8 - 10.4 lbs.)

40Vmax XGT BL AWS AFT Cordless Angle Grinder, Anti-Restart Function, Electric Brake, Large Trigger Switch

40V max



XGT BL AWS AFT XPT



	GA037G	GA038G
Wheel diameter	180 mm (7")	230 mm (9")
No load speed	7,800 min ⁻¹	6,600 min ⁻¹
Dimensions (L x W x H)	w/ BL4050F: 535 x 200 x 180 mm (21 x 7-7/8 x 7-1/8")	w/ BL4050F: 535 x 250 x 180 mm (21 x 9-7/8 x 7-1/8")
Net weight	5.0 kg (11.0 lbs.)	4.6-7.4 kg (10.1-16.3 lbs.)

40Vmax XGT BL AFT Cordless Angle Grinder, Anti-Restart Function, Electric Brake

40V max



XGT BL AFT XPT



GA035G:
Slide switch

GA036G:
Paddle switch

	GA035G	GA036G
Wheel diameter	150 mm (6")	150 mm (6")
No load speed	8,500 min ⁻¹	8,500 min ⁻¹
Dimensions (L x W x H)	w/ BL4040: 410 x 171 x 168 mm (16-1/8 x 6-3/4 x 6-5/8")	w/ BL4040F: 411 x 171 x 169 mm (16-1/4 x 6-3/4 x 6-5/8")
Net weight	3.0-3.7 kg (6.6-8.2 lbs.)	3.0 - 4.7 kg (6.6 - 10.4 lbs.)

18V X2 (36V) LXT BL ADT AFT Cordless Angle Grinder, Anti-Restart Function, Electric Brake, Large Trigger Switch

18V x2



DGA701 / DGA901

LXT BL ADT AFT AWS XPT



	DGA700	DGA701	DGA900	DGA901
Wheel diameter	180 mm (7")	180 mm (7")	230 mm (9")	230 mm (9")
No load speed	7,800 min ⁻¹	7,800 min ⁻¹	6,000 min ⁻¹	6,000 min ⁻¹
Dimensions (L x W x H)	499 x 200 x 158 mm (19-5/8 x 7-7/8 x 6-1/4")	499 x 200 x 158 mm (19-5/8 x 7-7/8 x 6-1/4")	499 x 250 x 158 mm (19-5/8 x 9-7/8 x 6-1/4")	499 x 250 x 158 mm (19-5/8 x 9-7/8 x 6-1/4")
Net weight	5.0-6.0 kg (11.02-13.23 lbs.)	5.0-6.0 kg (11.0-13.3 lbs.)	5.2-8 kg (11.46-17.64 lbs.)	5.2-8.0 kg (11.4-17.7 lbs.)

18V LXT BL AWS ADT AFT Cordless Angle Grinder, Variable Speed, Anti-Restart Function, Electric Brake, Slide Switch Lock-On

18V



LXT BL ADT AFT AWS XPT



	DGA414	DGA514
Wheel diameter	100 mm (4")	125 mm (5")
No load speed	3,000 - 8,500 min ⁻¹	3,000 - 8,500 min ⁻¹
Dimensions (L x W x H)	w/ BL1830B / BL1840B / BL1850B / BL1860B: 382 x 117 x 147 mm (15 x 4-5/8 x 5-3/4")	w/ BL1830B / BL1840B / BL1850B / BL1860B: 382 x 140 x 151 mm (15 x 5-1/2 x 5-15/16")
Net weight	2.2-2.8 kg (4.9-6.3 lbs.)	2.4-3 kg (5.2-6.7 lbs.)

18V LXT BL ADT AFT Cordless Angle Grinder, Variable Speed, Anti-Restart Function, Electric Brake, Slide Switch Lock-On

18V



LXT BL ADT AFT XPT



	DGA413	DGA463	DGA513
Wheel diameter	100 mm (4")	115 mm (4-1/2")	125 mm (5")
No load speed	3,000 - 8,500 min ⁻¹	3,000 - 8,500 min ⁻¹	3,000 - 8,500 min ⁻¹
Dimensions (L x W x H)	w/ BL1830B / BL1840B / BL1850B / BL1860B: 382 x 117 x 147 mm (15 x 4-5/8 x 5-3/4")	w/ BL1830B / BL1840B / BL1850B / BL1860B: 382 x 130 x 151 mm (15 x 5-1/8 x 5-15/16")	w/ BL1830B / BL1840B / BL1850B / BL1860B: 382 x 140 x 151 mm (15 x 5-1/2 x 5-15/16")
Net weight	2.2-2.8 kg (4.9-6.2 lbs.)	2.3-3 kg (5.1-6.7 lbs.)	2.4-3 kg (5.2-6.7 lbs.)

18V LXT BL AWS ADT AFT Cordless Angle Grinder, Variable Speed, Anti-Restart Function, Slide Switch Lock-On

18V



LXT BL ADT AFT AWS XPT



	DGA512
Wheel diameter	125 mm (5")
No load speed	3,000 - 8,500 min ⁻¹
Dimensions (L x W x H)	w/ BL1830B / BL1840B / BL1850B / BL1860B: 382 x 140 x 145 mm (15 x 5-1/2 x 5-3/4")
Net weight	2.3-3 kg (5.2-6.6 lbs.)

Grinding/Sanding/Polishing

18V LXT BL ADT AFT Cordless Angle Grinder, Variable Speed, Anti-Restart Function, Slide Switch Lock-On

18V



LXT BL ADT AFT XPT



	DGA411	DGA511
Wheel diameter	100 mm (4")	125 mm (5")
No load speed	3,000 - 8,500 min ⁻¹	3,000 - 8,500 min ⁻¹
Dimensions (L x W x H)	w/ BL1830B / BL1840B / BL1850B / BL1860B: 382 x 117 x 140 mm (15 x 4-5/8 x 5-1/2")	w/ BL1830B / BL1840B / BL1850B / BL1860B: 382 x 140 x 145 mm (15 x 5-1/2 x 5-3/4")
Net weight	2.2-2.8 kg (4.8-6.1 lbs.)	2.3-3 kg (5.1-6.6 lbs.)

18V LXT BL ADT AFT Cordless Angle Grinder, Anti-Restart Function, Electric Brake, Slide Switch Lock-On

18V



LXT BL ADT AFT XPT



	DGA406	DGA456	DGA506
Wheel diameter	100 mm (4")	115 mm (4-1/2")	125 mm (5")
No load speed	8,500 min ⁻¹	8,500 min ⁻¹	8,500 min ⁻¹
Dimensions (L x W x H)	362 x 117 x 146 mm (14-1/4 x 4-5/8 x 5-3/4")	362 x 130 x 151 mm (14-1/4 x 5-1/8 x 5-15/16")	362 x 140 x 151 mm (14-1/4 x 5-1/2 x 5-15/16")
Net weight	2.18-2.77 kg (4.81-6.12 lbs.)	2.34-3.03 kg (5.17-6.67 lbs.)	2.35-3.83 kg (5.18-8.45 lbs.)

18V LXT BL ADT AFT Cordless Angle Grinder, Anti-Restart Function, Slide Switch Lock-On

18V



DGA521

LXT BL ADT AFT XLock XPT



	DGA404	DGA454	DGA504	DGA521
Wheel diameter	100 mm (4")	115 mm (4-1/2")	125 mm (5")	125 mm (5")
No load speed	8,500 min ⁻¹	8,500 min ⁻¹	8,500 min ⁻¹	8,500 min ⁻¹
Dimensions (L x W x H)	362 x 117 x 140 mm (14-1/4 x 4-5/8 x 5-1/2")	362 x 130 x 145 mm (14-1/4 x 5-1/8 x 5-3/4")	362 x 140 x 145 mm (14-1/4 x 5-1/2 x 5-3/4")	w/ BL1830B / BL1840B / BL1850B / BL1860B: 375 x 140 x 146 mm (14-3/4 x 5-1/2 x 5-3/4")
Net weight	2.1-2.71 kg (4.63-5.98 lbs.)	2.24-2.89 kg (4.93-6.37 lbs.)	2.4 kg (5.3 lbs.)	2.4-3.0 kg (5.3-6.6 lbs.)

18V LXT Li-Ion Cordless Angle Grinder, Anti-Restart Function, Slide Switch Lock-On

18V



LXT



	DGA402	DGA452
Wheel diameter	100 mm (4")	115 mm (4-1/2")
No load speed	11,000 min ⁻¹	11,000 min ⁻¹
Dimensions (L x W x H)	317 x 118 x 118 mm (12-1/2 x 4-5/8 x 4-5/8")	317 x 129 x 126 mm (12-1/2 x 5-1/8 x 5")
Net weight	1.9-2.51 kg (4.19-5.54 lbs.)	2.06-2.71 kg (4.53-5.97 lbs.)

18V LXT BL AWS ADT AFT Cordless Angle Grinder, Variable Speed, Anti-Restart Function, Electric Brake, Paddle Switch

18V



LXT BL ADT AFT AWS XPT



	DGA418	DGA518
Wheel diameter	100 mm (4")	125 mm (5")
No load speed	3,000 - 8,500 min ⁻¹	3,000 - 8,500 min ⁻¹
Dimensions (L x W x H)	w/ BL1830B / BL1840B / BL1850B / BL1860B: 382 x 117 x 146 mm (15 x 4-5/8 x 5-3/4")	w/ BL1830B / BL1840B / BL1850B / BL1860B: 382 x 140 x 151 mm (15 x 5-1/2 x 6")
Net weight	2.2-2.9 kg (5-6.3 lbs.)	2.4-3.1 kg (5.3-6.8 lbs.)

18V LXT BL ADT AFT Cordless Angle Grinder, Variable Speed, Anti-Restart Function, Electric Brake, Paddle Switch

18V



LXT BL ADT AFT XPT



	DGA417	DGA467	DGA517
Wheel diameter	100 mm (4")	115 mm (4-1/2")	125 mm (5")
No load speed	3,000 - 8,500 min ⁻¹	3,000 - 8,500 min ⁻¹	3,000 - 8,500 min ⁻¹
Dimensions (L x W x H)	w/ BL1830B / BL1840B / BL1850B / BL1860B: 382 x 117 x 146 mm (15 x 4-5/8 x 5-3/4")	w/ BL1830B / BL1840B / BL1850B / BL1860B: 382 x 130 x 151 mm (15 x 5-1/8 x 6")	w/ BL1830B / BL1840B / BL1850B / BL1860B: 382 x 140 x 151 mm (15 x 5-1/2 x 6")
Net weight	2.2-2.9 kg (4.9-6.3 lbs.)	2.4-3.1 kg (5.2-6.7 lbs.)	2.4-3.1 kg (5.2-6.7 lbs.)

18V LXT BL ADT AFT Cordless Angle Grinder, Variable Speed, Anti-Restart Function, Electric Brake, Paddle Switch, X-LOCK

18V



LXT BL ADT AFT XLock XPT



	DGA419	DGA469	DGA519
Wheel diameter	100 mm (4")	115 mm (4-1/2")	125 mm (5")
No load speed	3,000 - 8,500 min ⁻¹	3,000 - 8,500 min ⁻¹	3,000 - 8,500 min ⁻¹
Dimensions (L x W x H)	w/ BL1830B / BL1840B / BL1850B / BL1860B: 396 x 117 x 147 mm (15-1/2 x 4-5/8 x 5-3/4")	w/ BL1830B / BL1840B / BL1850B / BL1860B: 396 x 130 x 147 mm (15-1/2 x 5-1/8 x 5-3/4")	w/ BL1830B / BL1840B / BL1850B / BL1860B: 396 x 140 x 147 mm (15-1/2 x 5-1/2 x 5-3/4")
Net weight	2.4-3.0 kg (5.3-6.6 lbs.)	2.5-3.1 kg (5.5-6.8 lbs.)	2.5-3.1 kg (5.5-6.8 lbs.)

Grinding/Sanding/Polishing

18V LXT BL ADT AFT Cordless Angle Grinder, Anti-Restart Function, Electric Brake, Paddle Switch No-Lock

18V



LXT BL ADT AFT XPT



	DGA408	DGA458	DGA508
Wheel diameter	100 mm (4")	115 mm (4-1/2")	125 mm (5")
No load speed	8,500 min ⁻¹	8,500 min ⁻¹	8,500 min ⁻¹
Dimensions (L x W x H)	362 x 117 x 146 mm (14-1/4 x 4-5/8 x 5-3/4")	362 x 130 x 151 mm (14-1/4 x 5-1/8 x 5-15/16")	362 x 140 x 151 mm (14-1/4 x 5-1/2 x 5-15/16")
Net weight	2.18-2.82 kg (4.81-6.17 lbs.)	2.34-3.03 kg (5.17-6.67 lbs.)	2.35-3.83 kg (5.18-8.45 lbs.)

18V LXT BL ADT AFT Cordless Angle Grinder, Anti-Restart Function, Paddle Switch No-Lock

18V



LXT BL ADT AFT XLock XPT



	DGA405	DGA455	DGA505	DGA520
Wheel diameter	100 mm (4")	115 mm (4-1/2")	125 mm (5")	125 mm (5")
No load speed	8,500 min ⁻¹	8,500 min ⁻¹	8,500 min ⁻¹	8,500 min ⁻¹
Dimensions (L x W x H)	362 x 117 x 140 mm (14-1/4 x 4-5/8 x 5-1/2")	362 x 130 x 145 mm (14-1/4 x 5-1/8 x 5-3/4")	362 x 140 x 145 mm (14-1/4 x 5-1/2 x 5-3/4")	w/ BL1830B / BL1840B / BL1850B / BL1860B: 376 x 140 x 147 mm (14-3/4 x 5-1/2 x 5-3/4")
Net weight	2.08-2.69 kg (4.59-5.94 lbs.)	2.24-2.92 kg (4.93-6.45 lbs.)	2.26-3.73 kg (4.98-8.23 lbs.)	2.4-3.0 kg (5.3-6.6 lbs.)

SJS II AFT Variable Speed Angle Grinder, Anti-Restart Function, Soft Start, Slide Switch



AFT SJS II



	GA4590	GA5090
Continuous rating Input	1,900W	1,900W
Wheel diameter	115 mm (4-1/2")	125 mm (5")
No load speed	2,800-11,500 min ⁻¹	2,800-11,500 min ⁻¹
Cutting depth	26 mm (1")	31 mm (1-1/4")
Circumference of grip portion	205 mm (8-1/8")	205 mm (8-1/8")
Dimensions (L x W x H)	326 x 130 x 123 mm (12-7/8 x 5-1/8 x 4-7/8")	326 x 130 x 123 mm (12-7/8 x 5-1/8 x 4-7/8")
Net weight	2.6 - 3.8 kg (5.7 - 8.4 lbs.)	2.6 - 3.8 kg (5.7 - 8.4 lbs.)

SJS II AFT Variable Speed Angle Grinder, Anti-Restart Function, Mechanical Brake, Soft Start, Slide Switch



AFT SJS II



	GA4591	GA5091
Continuous rating Input	1,900W	1,900W
Wheel diameter	115 mm (4-1/2")	125 mm (5")
No load speed	2,800 - 11,500 min ⁻¹	2,800 - 11,500 min ⁻¹
Cutting depth	26 mm (1")	31 mm (1-1/4")
Circumference of grip portion	205 mm (8-1/8")	205 mm (8-1/8")
Dimensions (L x W x H)	349 x 130 x 129 mm (13-3/4 x 5-1/8 x 5-1/8")	349 x 140 x 129 mm (13-3/4 x 5-1/2 x 5-1/8")
Net weight	2.8 - 4.0 kg (6.2 - 8.8 lbs.)	2.8 - 4.0 kg (6.2 - 8.8 lbs.)

SJS II AFT Angle Grinder, Anti-Restart Function, Soft Start, Slide Switch



AFT SJS II



	GA4592	GA5092
Continuous rating Input	1,900W	1,900W
Wheel diameter	115 mm (4-1/2")	125 mm (5")
No load speed	11,500 min ⁻¹	11,500 min ⁻¹
Cutting depth	26 mm (1")	31 mm (1-1/4")
Circumference of grip portion	205 mm (8-1/8")	205 mm (8-1/8")
Dimensions (L x W x H)	326 x 130 x 123 mm (12-7/8 x 5-1/8 x 4-7/8")	326 x 140 x 123 mm (12-7/8 x 5-1/2 x 4-7/8")
Net weight	2.6 - 3.8 kg (5.7 - 8.4 lbs.)	2.6 - 5.7 kg (5.7 - 8.4 lbs.)

SJS II AFT Variable Speed Angle Grinder, Anti-Restart Function, Soft Start, Mechanical Brake, Paddle Switch



AFT SJS II



	GA4593	GA5093
Continuous rating Input	1,900W	1,900W
Wheel diameter	115 mm (4-1/2")	125 mm (5")
No load speed	2,800-11,500 min ⁻¹	2,800-11,500 min ⁻¹
Cutting depth	26 mm (1")	31 mm (1-1/4")
Circumference of grip portion	207 mm (8-1/8")	207 mm (8-1/8")
Dimensions (L x W x H)	349 x 130 x 129 mm (13-3/4 x 5-1/8 x 5-1/8")	349 x 140 x 129 mm (13-3/4 x 5-1/2 x 5-1/8")
Net weight	2.8 - 4.0 kg (6.2 - 8.8 lbs.)	2.9 - 4.0 kg (6.4 - 8.8 lbs.)

SJS II AFT Angle Grinder, Anti-Restart Function, Soft Start, Mechanical Brake, Paddle Switch



AFT SJS II



	GA4594	GA5094
Continuous rating Input	1,900W	1,900W
Wheel diameter	115 mm (4-1/2")	125 mm (5")
No load speed	11,500 min ⁻¹	11,500 min ⁻¹
Cutting depth	26 mm (1")	31 mm (1-1/4")
Circumference of grip portion	207 mm (8-1/8")	207 mm (8-1/8")
Dimensions (L x W x H)	349 x 130 x 129 mm (13-3/4 x 5-1/8 x 5-1/8")	349 x 140 x 129 mm (13-3/4 x 5-1/2 x 5-1/8")
Net weight	2.8 - 4.0 kg (6.2 - 8.8 lbs.)	2.9 - 4.0 kg (6.4 - 8.8 lbs.)

Grinding/Sanding/Polishing

SJS II AFT Angle Grinder, Anti-Restart Function, Soft Start, Paddle Switch



	GA4595	GA5095
Continuous rating Input	1,900W	1,900W
Wheel diameter	115 mm (4-1/2")	125 mm (5")
No load speed	11,500 min ⁻¹	11,500 min ⁻¹
Cutting depth	26 mm (1")	31 mm (1-1/4")
Circumference of grip portion	207 mm (8-1/8")	207 mm (8-1/8")
Dimensions (L x W x H)	326 x 130 x 123 mm (12-7/8 x 5-1/8 x 4-7/8")	326 x 140 x 123 mm (12-7/8 x 5-1/2 x 4-7/8")
Net weight	2.6 - 3.8 kg (5.7 - 8.4 lbs.)	2.6 - 3.8 kg (5.7 - 8.4 lbs.)

SJS Angle Grinder, Anti-Restart Function, Soft Start, Large Trigger Switch



	GA5021C	GA6021C
Continuous rating Input	1,450W	1,450W
Wheel diameter	125 mm (5")	150 mm (6")
No load speed	10,000 min ⁻¹	9,000 min ⁻¹
Dimensions (L x W x H)	390 x 139 x 120 mm (15-3/8 x 5-1/2 x 4-3/4")	390 x 169 x 120 mm (15-3/8 x 6-5/8 x 4-3/4")
Net weight	2.4 kg (5.3 lbs.)	3 - 3.5 kg (6.7 - 7.6 lbs.)

SJS Angle Grinder, Anti-Restart Function, Soft Start, Finger Trigger Switch



	GA5020C	GA6020C
Continuous rating Input	1,450W	1,450W
Wheel diameter	125 mm (5")	150 mm (6")
No load speed	10,000 min ⁻¹	9,000 min ⁻¹
Dimensions (L x W x H)	390 x 139 x 120 mm (15-3/8 x 5-1/2 x 4-3/4")	390 x 169 x 120 mm (15-3/8 x 6-5/8 x 4-3/4")
Net weight	2.9 - 4.1 kg (6.5 - 9.1 lbs.)	3 - 3.5 kg (6.7 - 7.6 lbs.)

SJS II Variable Speed Angle Grinder, Anti-Restart Function, Mechanical Brake, Soft Start, Slide Switch



	GA5041C
Continuous rating Input	1,400W
Wheel diameter	125 mm (5")
No load speed	2,800-11,000 min ⁻¹
Dimensions (L x W x H)	325 x 140 x 121 mm (12-3/4 x 5-1/2 x 4-3/4")
Net weight	2.7 - 3.8 kg (5.9 - 8.4 lbs.)

SJS II Variable Speed Angle Grinder, Anti-Restart Function, Soft Start, Slide Switch



	GA4040C	GA4540C	GA5040C	GA6040C
Continuous rating Input	1,400W	1,400W	1,400W	1,400W
Wheel diameter	100 mm (4")	115 mm (4-1/2")	125 mm (5")	150 mm (6")
No load speed	2,800-11,000 min ⁻¹	2,800-11,000 min ⁻¹	2,800-11,000 min ⁻¹	4,000-9,000 min ⁻¹
Dimensions (L x W x H)	303 x 117 x 111 mm (11-7/8 x 4-5/8 x 4-3/8")	303 x 130 x 116 mm (11-7/8 x 5-1/8 x 4-9/16")	303 x 140 x 116 mm (11-7/8 x 5-1/2 x 4-9/16")	303 x 171 x 116 mm (11-7/8 x 6-3/4 x 4-9/16")
Net weight	2.3 - 2.6 kg (5.1 - 5.7 lbs.)	2.4 - 2.8 kg (5.4 - 6.2 lbs.)	2.5 - 3.6 kg (5.6 - 8 lbs.)	2.5 - 2.9 kg (5.5 - 6.4 lbs.)

SJS II Variable Speed Angle Grinder, Soft Start, Slide Switch



	GA4542C	GA5042C	GA6042C
Continuous rating Input	1,400W	1,400W	1,400W
Wheel diameter	115 mm (4-1/2")	125 mm (5")	150 mm (6")
No load speed	2,800-11,000 min ⁻¹	2,800-11,000 min ⁻¹	4,000-9,000 min ⁻¹
Dimensions (L x W x H)	303 x 130 x 116 mm (11-7/8 x 5-1/8 x 4-9/16")	303 x 140 x 116 mm (11-7/8 x 5-1/2 x 4-9/16")	303 x 171 x 116 mm (11-7/8 x 6-3/4 x 4-9/16")
Net weight	2.4 - 2.8 kg (5.2 - 6.2 lbs.)	2.5 - 3.6 kg (5.4 - 8 lbs.)	2.5 - 2.9 kg (5.5 - 6.4 lbs.)

SJS Variable Speed Angle Grinder, Anti-Restart Function, Soft Start, Slide Switch



	9565CVR	9564CV	9565CV
Continuous rating Input	1,400W	1,400W	1,400W
Wheel diameter	125 mm (5")	115 mm (4-1/2")	125 mm (5")
No load speed	2,800-12,000 min ⁻¹	2,800-12,000 min ⁻¹	2,800-12,000 min ⁻¹
Dimensions (L x W x H)	299 x 139 x 103 mm (11-3/4 x 5-1/2 x 4-1/16")	299 x 129 x 103 mm (11-3/4 x 5-1/16 x 4")	299 x 139 x 103 mm (11-3/4 x 5-1/2 x 4-1/16")
Net weight	2.4 - 3.5 kg (5.2 - 7.7 lbs.)	2.3 - 2.6 kg (5.1 - 5.8 lbs.)	2.4 - 3.5 kg (5.2 - 7.7 lbs.)

SJS Angle Grinder, Anti-Restart Function, Soft Start, Slide Switch



	9565CR
Continuous rating Input	1,400W
Wheel diameter	125 mm (5")
No load speed	12,000 min ⁻¹
Dimensions (L x W x H)	299 x 139 x 103 mm (11-3/4 x 5-1/2 x 4-1/16")
Net weight	2.4 - 3.5 kg (5.2 - 7.7 lbs.)

SJS Angle Grinder, Slide Switch



	9565C	9566C
Continuous rating Input	1,400W	1,400W
Wheel diameter	125 mm (5")	150 mm (6")
No load speed	12,000 min ⁻¹	10,000 min ⁻¹
Dimensions (L x W x H)	299 x 139 x 103 mm (11-3/4 x 5-1/2 x 4-1/16")	299 x 169 x 103 mm (11-3/4 x 6-5/8 x 4-1/16")
Net weight	2.4 - 3.5 kg (5.3 - 7.7 lbs.)	2.5 - 2.8 kg (5.4 - 6.2 lbs.)

SJS Variable Speed Angle Grinder, Soft Start, Paddle Switch



	9564PCV	9565PCV	9566PCV
Continuous rating Input	1,400W	1,400W	1,400W
Wheel diameter	115 mm (4-1/2")	125 mm (5")	150 mm (6")
No load speed	2,800-12,000 min ⁻¹	12,000 min ⁻¹	4,000-10,000 min ⁻¹
Dimensions (L x W x H)	307 x 129 x 103 mm (12-1/8 x 5-1/8 x 4")	307 x 139 x 103 mm (12-1/8 x 5-1/2 x 4")	307 x 169 x 103 mm (12-1/8 x 6-5/8 x 4")
Net weight	2.4 - 2.7 kg (5.3 - 5.9 lbs.)	2.4 - 3.5 kg (5.3 - 7.7 lbs.)	2.4 - 2.8 kg (5.3 - 6.2 lbs.)

SJS Angle Grinder, Soft Start, Paddle Switch



	9564PC	9565PC	9566PC
Continuous rating Input	1,400W	1,400W	1,400W
Wheel diameter	115 mm (4-1/2")	125 mm (5")	150 mm (6")
No load speed	12,000 min ⁻¹	12,000 min ⁻¹	10,000 min ⁻¹
Dimensions (L x W x H)	307 x 129 x 103 mm (12-1/8 x 5-1/8 x 4")	307 x 139 x 103 mm (12-1/8 x 5-1/2 x 4")	307 x 169 x 103 mm (12-1/8 x 6-5/8 x 4")
Net weight	2.4 - 2.7 kg (5.3 - 6 lbs.)	2.4 - 3.5 kg (5.3 - 7.7 lbs.)	2.4 - 2.8 kg (5.3 - 6.2 lbs.)

SJS Angle Grinder, Anti-Restart Function, Soft Start, Slide Switch, X-LOCK



	GA5080R	GA5080
Continuous rating Input	1,400W	1,400W
Wheel diameter	125 mm (5")	125 mm (5")
No load speed	12,000 min ⁻¹	12,000 min ⁻¹
Cutting depth	31 mm (1-1/4")	31 mm (1-1/4")
Circumference of grip portion	205 mm (8-1/8")	205 mm (8-1/8")
Dimensions (L x W x H)	309 x 141 x 113 mm (12-1/8 x 5-9/16 x 4-7/16")	309 x 141 x 113 mm (12-1/8 x 5-9/16 x 4-7/16")
Net weight	2.5 - 3.6 kg (5.5 - 7.9 lbs.)	2.5 - 3.6 kg (5.5 - 7.9 lbs.)

Angle Grinder, Paddle Switch



	GA4050	GA4550	GA5050
Continuous rating Input	1,300W	1,300W	1,300W
Wheel diameter	100 mm (4")	115 mm (4-1/2")	125 mm (5")
No load speed	11,000 min ⁻¹	11,000 min ⁻¹	11,000 min ⁻¹
Circumference of grip portion	212 mm (8-3/8")	212 mm (8-3/8")	212 mm (8-3/8")
Dimensions (L x W x H)	325 x 117 x 100 mm (12-3/4 x 4-5/8 x 4-5/16")	325 x 130 x 117 mm (12-3/4 x 5-1/8 x 4-5/8")	325 x 140 x 117 mm (12-3/4 x 5-1/2 x 4-5/8")
Net weight	2.3 - 2.6 kg (5.1 - 5.7 lbs.)	2.4 - 2.8 kg (5.3 - 6.2 lbs.)	2.5 - 2.8 kg (5.5 - 6.2 lbs.)

Angle Grinder, Paddle Switch



	GA4552	GA5052
Continuous rating Input	1,300W	1,300W
Wheel diameter	115 mm (4-1/2")	125 mm (5")
No load speed	11,000 min ⁻¹	11,000 min ⁻¹
Circumference of grip portion	212 mm (8-3/8")	212 mm (8-3/8")
Dimensions (L x W x H)	325 x 130 x 117 mm (12-3/4 x 5-1/8 x 4-5/8")	325 x 140 x 117 mm (12-3/4 x 5-1/2 x 4-5/8")
Net weight	2.4 - 2.8 kg (5.3 - 6.2 lbs.)	2.5 - 2.8 kg (5.5 - 6.2 lbs.)

Grinding/Sanding/Polishing

Angle Grinder, Anti-Restart Function, Paddle Switch



	GA4050R	GA4550R	GA5050R
Continuous rating Input	1,300W	1,300W	1,300W
Wheel diameter	100 mm (4")	115 mm (4-1/2")	125 mm (5")
No load speed	11,000 min ⁻¹	11,000 min ⁻¹	11,000 min ⁻¹
Circumference of grip portion	212 mm (8-3/8")	212 mm (8-3/8")	212 mm (8-3/8")
Dimensions (L x W x H)	325 x 117 x 100 mm (12-3/4 x 4-5/8 x 4-5/16")	325 x 130 x 117 mm (12-3/4 x 5-1/8 x 4-5/8")	325 x 140 x 117 mm (12-3/4 x 5-1/2 x 4-5/8")
Net weight	2.3 - 2.6 kg (5.1 - 5.7 lbs.)	2.4 - 2.8 kg (5.3 - 6.2 lbs.)	2.5 - 2.8 kg (5.5 - 6.2 lbs.)



Angle Grinder, Anti-Restart Function, Paddle Switch



	GA4552R	GA5052R
Continuous rating Input	1,300W	1,300W
Wheel diameter	115 mm (4-1/2")	125 mm (5")
No load speed	11,000 min ⁻¹	11,000 min ⁻¹
Circumference of grip portion	212 mm (8-3/8")	212 mm (8-3/8")
Dimensions (L x W x H)	325 x 130 x 117 mm (12-3/4 x 5-1/8 x 4-5/8")	325 x 140 x 117 mm (12-3/4 x 5-1/2 x 4-5/8")
Net weight	2.4 - 2.8 kg (5.3 - 6.2 lbs.)	2.5 - 2.8 kg (5.5 - 6.2 lbs.)



90°

Angle Grinder, Anti-Restart Function, Paddle Switch, Undetachable Wheel Cover



	GA4051R	GA4551R	GA5051R
Continuous rating Input	1,300W	1,300W	1,300W
Wheel diameter	100 mm (4")	115 mm (4-1/2")	125 mm (5")
No load speed	11,000 min ⁻¹	11,000 min ⁻¹	11,000 min ⁻¹
Circumference of grip portion	212 mm (8-3/8")	212 mm (8-3/8")	212 mm (8-3/8")
Dimensions (L x W x H)	325 x 117 x 100 mm (12-3/4 x 4-5/8 x 4-5/16")	325 x 130 x 117 mm (12-3/4 x 5-1/8 x 4-5/8")	325 x 140 x 117 mm (12-3/4 x 5-1/2 x 4-5/8")
Net weight	2.3 - 2.5 kg (5.1 - 5.5 lbs.)	2.4 - 2.7 kg (5.3 - 6.0 lbs.)	2.5 - 2.7 kg (5.5 - 6.0 lbs.)



Angle Grinder, Anti-Restart Function, Paddle Switch, Undetachable Wheel Cover



	GA4553R	GA5053R
Continuous rating Input	1,300W	1,300W
Wheel diameter	115 mm (4-1/2")	125 mm (5")
No load speed	11,000 min ⁻¹	11,000 min ⁻¹
Circumference of grip portion	212 mm (8-3/8")	212 mm (8-3/8")
Dimensions (L x W x H)	325 x 130 x 117 mm (12-3/4 x 5-1/8 x 4-5/8")	325 x 140 x 117 mm (12-3/4 x 5-1/2 x 4-5/8")
Net weight	2.4 - 2.7 kg (5.3 - 6.0 lbs.)	2.5 - 2.7 kg (5.5 - 6.0 lbs.)



90°

SJS II Angle Grinder, Anti-Restart Function, Soft Start, Slide Switch



	GA4540R	GA5040R	GA6040R
Continuous rating Input	1,100W	1,100W	1,100W
Wheel diameter	115 mm (4-1/2")	125 mm (5")	150 mm (6")
No load speed	11,000 min ⁻¹	11,000 min ⁻¹	9,000 min ⁻¹
Dimensions (L x W x H)	303 x 130 x 116 mm (11-7/8 x 5-1/8 x 4-9/16")	303 x 140 x 116 mm (11-7/8 x 5-1/2 x 4-9/16")	303 x 171 x 116 mm (11-7/8 x 6-3/4 x 4-9/16")
Net weight	2.4 - 2.8 kg (5.4 - 6.1 lbs.)	2.5 - 3.6 kg (5.4 - 8 lbs.)	2.5 - 2.9 kg (5.5 - 6.4 lbs.)



SJS II Angle Grinder, Slide Switch



	GA4040	GA4540	GA5040	GA6040
Continuous rating Input	1,100W	1,100W	1,100W	1,100W
Wheel diameter	100 mm (4")	115 mm (4-1/2")	125 mm (5")	150 mm (6")
No load speed	11,000 min ⁻¹	11,000 min ⁻¹	11,000 min ⁻¹	9,000 min ⁻¹
Dimensions (L x W x H)	303 x 117 x 111 mm (11-7/8 x 4-5/8 x 4-3/8")	303 x 130 x 116 mm (11-7/8 x 5-1/8 x 4-9/16")	303 x 140 x 116 mm (11-7/8 x 5-1/2 x 4-9/16")	303 x 171 x 116 mm (11-7/8 x 6-3/4 x 4-9/16")
Net weight	2.2 - 2.5 kg (4.9 - 5.6 lbs.)	2.3 - 2.7 kg (5.2 - 5.9 lbs.)	2.4 - 3.5 kg (5.2 - 7.8 lbs.)	2.4 - 2.8 kg (5.3 - 6.2 lbs.)



SJS Angle Grinder, Anti-Restart Function, Soft Start, Slide Switch



	9565HR
Continuous rating Input	1,100W
Wheel diameter	125 mm (5")
No load speed	12,000 min ⁻¹
Dimensions (L x W x H)	299 x 140 x 111 mm (11-3/4 x 5-1/2 x 4-3/8")
Net weight	2.4 - 3.5 kg (5.2 - 7.6 lbs.)



SJS Angle Grinder, Paddle Switch



9564P

Continuous rating Input	1,100W
Wheel diameter	115 mm (4-1/2")
No load speed	12,000 min ⁻¹
Dimensions (L x W x H)	307 x 129 x 103 mm (12-1/8 x 5-1/8 x 4")
Net weight	2.4 - 2.7 kg (5.3 - 5.9 lbs.)

SJS Angle Grinder, Large Trigger Switch



GA5021 / GA6021



GA5021

Continuous rating Input	1,050W
Wheel diameter	125 mm (5")
No load speed	10,000 min ⁻¹
Dimensions (L x W x H)	384 x 139 x 120 mm (15-1/8 x 5-1/2 x 4-3/4")
Net weight	2.7 - 3.9 kg (6 - 8.6 lbs.)

GA5011

Continuous rating Input	1,050W
Wheel diameter	125 mm (5")
No load speed	12,000 min ⁻¹
Dimensions (L x W x H)	384 x 139 x 113 mm (15-1/8 x 5-1/2 x 4-7/16")
Net weight	2.6 - 3.8 kg (5.8 - 8.4 lbs.)

GA6021

Continuous rating Input	1,050W
Wheel diameter	150 mm (6")
No load speed	10,000 min ⁻¹
Dimensions (L x W x H)	384 x 172 x 120 mm (15-1/8 x 6-3/4 x 4-3/4")
Net weight	2.8 - 3.2 kg (6.1 - 7.1 lbs.)

SJS Angle Grinder, Finger Trigger Switch



GA5020 / GA6020



GA5020

Continuous rating Input	1,050W
Wheel diameter	125 mm (5")
No load speed	12,000 min ⁻¹
Dimensions (L x W x H)	356 x 139 x 120 mm (14 x 5-1/2 x 4-3/4")
Net weight	2.7 - 3.9 kg (6 - 8.6 lbs.)

GA5010

Continuous rating Input	1,050W
Wheel diameter	125 mm (5")
No load speed	12,000 min ⁻¹
Dimensions (L x W x H)	356 x 139 x 112 mm (14 x 5-1/2 x 4-3/8")
Net weight	2.6 - 3.8 kg (5.8 - 8.4 lbs.)

GA6020

Continuous rating Input	1,050W
Wheel diameter	150 mm (6")
No load speed	10,000 min ⁻¹
Dimensions (L x W x H)	356 x 169 x 120 mm (14 x 6-5/8 x 4-3/4")
Net weight	2.8 - 3.2 kg (6.1 - 7.1 lbs.)

GA6010

Continuous rating Input	1,050W
Wheel diameter	150 mm (6")
No load speed	10,000 min ⁻¹
Dimensions (L x W x H)	356 x 169 x 112 mm (14 x 6-5/8 x 4-3/8")
Net weight	2.7 - 3.1 kg (5.9 - 6.9 lbs.)

Angle Grinder, Anti-Restart Function, Soft Start, Slide Switch, Speed Adjusting Dial

new



GA4100

Continuous rating Input	850W
Wheel diameter	100 mm (4")
No load speed	2,800-11,000 min ⁻¹
Cutting depth	20 mm (13/16")
Circumference of grip portion	191 mm (7-1/2")
Dimensions (L x W x H)	298 x 118 x 105 mm (11-3/4 x 4-5/8 x 4-1/8")
Net weight	2.0 kg (4.4 lbs.)

GA4600

Continuous rating Input	850W
Wheel diameter	115 mm (4-1/2")
No load speed	2,800-11,000 min ⁻¹
Cutting depth	28 mm (1-1/8")
Circumference of grip portion	191 mm (7-1/2")
Dimensions (L x W x H)	298 x 130 x 111 mm (11-3/4 x 5-1/8 x 4-3/8")
Net weight	2.2 kg (4.9 lbs.)

GA5100

Continuous rating Input	850W
Wheel diameter	125 mm (5")
No load speed	2,800-11,000 min ⁻¹
Cutting depth	33 mm (1-5/16")
Circumference of grip portion	191 mm (7-1/2")
Dimensions (L x W x H)	298 x 140 x 111 mm (11-3/4 x 5-1/2 x 4-3/8")
Net weight	2.2 kg (4.9 lbs.)

Angle Grinder, Slide Switch, X-LOCK



X-LOCK



GA4570

Continuous rating Input	840W
Wheel diameter	115 mm (4-1/2")
No load speed	11,000 min ⁻¹
Cutting depth	26 mm (1")
Circumference of grip portion	195 mm (7-5/8")
Dimensions (L x W x H)	288 x 131 x 112 mm (11-3/8 x 5-1/8 x 4-3/8")
Net weight	2.2 - 2.5 kg (4.9 - 5.5 lbs.)

Angle Grinder, Toggle Switch



9556HB

Continuous rating Input	840W
Wheel diameter	100 mm (4")
No load speed	11,000 min ⁻¹
Dimensions (L x W x H)	271 x 118 x 97 mm (10-5/8 x 4-5/8 x 3-13/16")
Net weight	1.6 - 2 kg (3.6 - 4.4 lbs.)

9556HN

Continuous rating Input	840W
Wheel diameter	100 mm (4")
No load speed	11,000 min ⁻¹
Dimensions (L x W x H)	271 x 118 x 97 mm (10-5/8 x 4-5/8 x 3-13/16")
Net weight	1.6 - 2 kg (3.6 - 4.4 lbs.)

9557HN

Continuous rating Input	840W
Wheel diameter	115 mm (4-1/2")
No load speed	11,000 min ⁻¹
Dimensions (L x W x H)	271 x 129 x 106 mm (10-5/8 x 5-1/8 x 4-3/16")
Net weight	1.7 - 2.2 kg (3.8 - 4.8 lbs.)

9558HN

Continuous rating Input	840W
Wheel diameter	125 mm (5")
No load speed	11,000 min ⁻¹
Dimensions (L x W x H)	271 x 139 x 106 mm (10-5/8 x 5-1/2 x 4-3/16")
Net weight	1.7 - 3 kg (3.8 - 6.6 lbs.)

Angle Grinder, Slide Switch



9556HNR



9556HNR

Continuous rating Input	840W
Wheel diameter	100 mm (4")
No load speed	11,000 min ⁻¹
Circumference of grip portion	195 mm (7-5/8")
Dimensions (L x W x H)	271 x 118 x 106 mm (10-5/8 x 4-5/8 x 4-3/16")
Net weight	1.9 - 2.9 kg (4.2 - 6.4 lbs.)

9557HNR

Continuous rating Input	840W
Wheel diameter	115 mm (4-1/2")
No load speed	11,000 min ⁻¹
Circumference of grip portion	-
Dimensions (L x W x H)	271 x 130 x 106 mm (10-5/8 x 5-1/8 x 4-3/16")
Net weight	1.7 - 2.4 kg (3.8 - 5.3 lbs.)

9558HNR

Continuous rating Input	840W
Wheel diameter	125 mm (5")
No load speed	11,000 min ⁻¹
Circumference of grip portion	-
Dimensions (L x W x H)	271 x 140 x 106 mm (10-5/8 x 5-1/2 x 4-3/16")
Net weight	1.7 - 3.2 kg (3.8 - 7.1 lbs.)

Grinding/Sanding/Polishing

Angle Grinder, Paddle Switch



	9556HP	9557HP	9558HP
Continuous rating Input	840W	840W	840W
Wheel diameter	100 mm (4")	115 mm (4-1/2")	125 mm (5")
No load speed	11,000 min ⁻¹	11,000 min ⁻¹	11,000 min ⁻¹
Dimensions (L x W x H)	273 x 118 x 97 mm (10-3/4 x 4-5/8 x 3-13/16")	273 x 129 x 106 mm (10-3/4 x 5-1/8 x 4-3/16")	273 x 139 x 106 mm (10-3/4 x 5-1/2 x 4-3/16")
Net weight	1.7 - 2 kg (3.7 - 4.5 lbs.)	1.7 - 2.2 kg (3.7 - 4.9 lbs.)	1.8 - 3 kg (3.9 - 6.7 lbs.)



Angle Grinder, Toggle Switch



	GA4031	GA4032
Continuous rating Input	720W	720W
Wheel diameter	100 mm (4")	100 mm (4")
No load speed	11,000 min ⁻¹	9,000 min ⁻¹
Dimensions (L x W x H)	259 x 118 x 104 mm (10-1/4 x 4-5/8 x 4-1/8")	259 x 118 x 104 mm (10-1/4 x 4-5/8 x 4-1/8")
Net weight	1.6 kg (3.5 lbs.)	1.6 kg (3.5 lbs.)



Angle Grinder, Anti-Restart Function, Soft Start, Slide Switch



	GA4030R	GA4530R	GA5030R
Continuous rating Input	720W	720W	720W
Wheel diameter	100 mm (4")	115 mm (4-1/2")	125 mm (5")
No load speed	11,000 min ⁻¹	11,000 min ⁻¹	11,000 min ⁻¹
Dimensions (L x W x H)	266 x 118 x 102 mm (10-1/2 x 4-5/8 x 4")	266 x 130 x 108 mm (10-1/2 x 5-1/2 x 4-1/4")	266 x 140 x 108 mm (10-1/2 x 5-1/2 x 4-1/4")
Net weight	1.72 - 2.01 kg (3.79 - 4.43 lbs.)	1.88 - 2.22 kg (4.14 - 4.89 lbs.)	1.91 - 3.06 kg (4.21 - 6.75 lbs.)



Angle Grinder, Slide Switch



	GA4030	GA4530	GA5030
Continuous rating Input	720W	720W	720W
Wheel diameter	100 mm (4")	115 mm (4-1/2")	125 mm (5")
No load speed	11,000 min ⁻¹	11,000 min ⁻¹	11,000 min ⁻¹
Dimensions (L x W x H)	266 x 117 x 95 mm (10-1/2 x 4-5/8 x 3-3/4")	266 x 128 x 103 mm (10-1/2 x 5 x 4-1/16")	266 x 138 x 103 mm (10-1/2 x 5-7/16 x 4-1/16")
Net weight	1.73 - 2.02 kg (3.81 - 4.45 lbs.)	1.89 - 2.23 kg (4.17 - 4.91 lbs.)	1.92 - 3.07 kg (4.23 - 6.77 lbs.)



Angle Grinder, Paddle Switch



	GA4034	GA4534	GA5034
Continuous rating Input	720W	720W	720W
Wheel diameter	100 mm (4")	115 mm (4-1/2")	125 mm (5")
No load speed	11,000 min ⁻¹	11,000 min ⁻¹	11,000 min ⁻¹
Dimensions (L x W x H)	265 x 118 x 95 mm (10-3/8 x 4-5/8 x 3-3/4")	265 x 128 x 103 mm (10-3/8 x 5 x 4-1/16")	265 x 139 x 103 mm (10-3/8 x 5-1/2 x 4-1/16")
Net weight	1.8 kg (4.0 lbs.)	1.98 - 2.31 kg (4.37 - 5.09 lbs.)	2 - 3.15 kg (4.41 - 6.94 lbs.)



Angle Grinder, Slide Switch



	9553HN	9553HB	9554HN	9555HN
Continuous rating Input	710W	710W	710W	710W
Wheel diameter	100 mm (4")	100 mm (4")	115 mm (4-1/2")	125 mm (5")
No load speed	11,000 min ⁻¹	11,000 min ⁻¹	10,000 min ⁻¹	10,000 min ⁻¹
Dimensions (L x W x H)	258 x 118 x 97 mm (10-1/8 x 4-5/8 x 3-13/16")	258 x 118 x 97 mm (10-1/8 x 4-5/8 x 3-13/16")	258 x 129 x 106 mm (10-1/8 x 5-1/8 x 4-3/16")	258 x 139 x 106 mm (10-1/8 x 5-1/2 x 4-3/16")
Net weight	1.5 - 1.8 kg (3.2 - 4.1 lbs.)	1.5 - 1.9 kg (3.3 - 4.1 lbs.)	1.6 - 2 kg (3.5 - 4.4 lbs.)	1.6 - 2.9 kg (3.5 - 6.3 lbs.)



Angle Grinder, Toggle Switch

9500NB: Double Insulation



	9500NB	N9500N
Continuous rating Input	570W	570W
Wheel diameter	100 mm (4")	100 mm (4")
No load speed	12,000 min ⁻¹	12,000 min ⁻¹
Overall length	253 mm (10")	245 mm (9-5/8")
Net weight	1.9 kg (3.5 lbs.)	1.6 - 1.9 kg (3.5 - 4.2 lbs.)



N9500N: Disc Grinderson

AFT Angle Grinder, Anti-Restart Function, Soft Start, Mechanical Brake, Large Trigger Switch



AFT



	GA7070	GA9070
Continuous rating Input	2,800W	2,800W
Wheel diameter	180 mm (7")	230 mm (9")
No load speed	8,500 min ⁻¹	6,600 min ⁻¹
Dimensions (L x W x H)	506 x 200 x 146 mm (20 x 7-7/8 x 5-3/4")	506 x 250 x 146 mm (20 x 9-7/8 x 5-3/4")
Net weight	6.1 - 6.6 kg (13.5 - 14.6 lbs.)	6.3 - 8.5 kg (13.9 - 18.7 lbs.)

AFT D-Handle Angle Grinder, Anti-Restart Function, Soft Start, Mechanical Brake, Large Trigger Switch



AFT



	GA9071
Continuous rating Input	2,800W
Wheel diameter	230 mm (9")
No load speed	6,600 min ⁻¹
Dimensions (L x W x H)	506 x 250 x 146 mm (20 x 9-7/8 x 5-3/4")
Net weight	6.4 - 8.5 kg (14.1 - 18.7 lbs.)

Angle Grinder, Anti-Restart Function, Soft Start, Large Trigger Switch



	GA7080	GA9080
Continuous rating Input	2,700W	2,700W
Wheel diameter	180 mm (7")	230 mm (9")
No load speed	8,500 min ⁻¹	6,600 min ⁻¹
Dimensions (L x W x H)	509 x 200 x 144 mm (20 x 7-7/8 x 5-5/8")	509 x 250 x 144 mm (20 x 9-7/8 x 5-5/8")
Net weight	6.3 - 6.8 kg (13.9 - 15.0 lbs.)	6.5 - 8.6 kg (14.3 - 19.0 lbs.)

Angle Grinder, Anti-Restart Function, Soft Start, Large Trigger Switch



	GA7081	GA9081
Continuous rating Input	2,700W	2,700W
Wheel diameter	180 mm (7")	230 mm (9")
No load speed	8,500 min ⁻¹	6,600 min ⁻¹
Dimensions (L x W x H)	461 x 200 x 144 mm (18-1/8 x 7-7/8 x 5-5/8")	461 x 250 x 144 mm (18-1/8 x 9-7/8 x 5-5/8")
Net weight	6.1 - 6.6 kg (13.4 - 14.6 lbs.)	6.3 - 8.4 kg (13.9 - 18.5 lbs.)

Angle Grinder, Large Trigger Switch



	GA7082	GA9082
Continuous rating Input	2,700W	2,700W
Wheel diameter	180 mm (7")	230 mm (9")
No load speed	8,500 min ⁻¹	6,600 min ⁻¹
Dimensions (L x W x H)	461 x 200 x 144 mm (18-1/8 x 7-7/8 x 5-5/8")	461 x 250 x 144 mm (18-1/8 x 9-7/8 x 5-5/8")
Net weight	6.0 - 6.5 kg (13.2 - 14.3 lbs.)	6.2 - 8.3 kg (13.7 - 18.3 lbs.)

Angle Grinder, Anti-Restart Function, Soft Start, Large Trigger Switch



	GA9040R
Continuous rating Input	2,600W
Wheel diameter	230 mm (9")
No load speed	6,600 min ⁻¹
Dimensions (L x W x H)	503 x 250 x 140 mm (19-3/4 x 9-7/8 x 5-1/2")
Net weight	6.69 - 8.98 kg (14.8 - 19.6 lbs.)

Angle Grinder, Soft Start, Large Trigger Switch



	GA7040S	GA9040S
Continuous rating Input	2,600W	2,600W
Wheel diameter	180 mm (7")	230 mm (9")
No load speed	8,500 min ⁻¹	6,600 min ⁻¹
Dimensions (L x W x H)	511 x 200 x 140 mm (20-1/8 x 7-7/8 x 5-1/2")	503 x 250 x 140 mm (19-3/4 x 9-7/8 x 5-1/2")
Net weight	6.45 - 6.95 kg (14.2 - 15.3 lbs.)	6.65 - 8.94 kg (14.7 - 19.7 lbs.)

Grinding/Sanding/Polishing

Angle Grinder, Anti-Restart Function, Soft Start, Large Trigger Switch



	GA7030R	GA9030R
Continuous rating Input	2,400W	2,400W
Wheel diameter	180 mm (7")	230 mm (9")
No load speed	8,500 min ⁻¹	6,600 min ⁻¹
Dimensions (L x W x H)	503 x 200 x 140 mm (19-3/4 x 7-7/8 x 5-1/2")	503 x 250 x 140 mm (19-3/4 x 9-7/8 x 5-1/2")
Net weight	6.17 - 6.67 kg (13.6 - 14.7 lbs.)	6.36 - 8.65 kg (14 - 19.1 lbs.)



Angle Grinder, Soft Start, Large Trigger Switch



	GA9030S
Continuous rating Input	2,400W
Wheel diameter	230 mm (9")
No load speed	6,600 min ⁻¹
Dimensions (L x W x H)	503 x 250 x 140 mm (19-3/4 x 9-7/8 x 5-1/2")
Net weight	6.27 - 8.56 kg (13.8 - 18.9 lbs.)



Angle Grinder, Large Trigger Switch



	GA7030	GA9030
Continuous rating Input	2,400W	2,400W
Wheel diameter	180 mm (7")	230 mm (9")
No load speed	8,500 min ⁻¹	6,600 min ⁻¹
Dimensions (L x W x H)	511 x 200 x 140 mm (20-1/8 x 7-7/8 x 5-1/2")	503 x 250 x 140 mm (19-3/4 x 9-7/8 x 5-1/2")
Net weight	6.06 - 6.56 kg (13.36 - 14.46 lbs.)	6.26 - 8.55 kg (13.8 - 18.9 lbs.)



Angle Grinder, AC/DC Trigger Switch

AC/ DC Trigger Switch



	GA7031	GA9031
Continuous rating Input	2,400W	2,400W
Wheel diameter	180 mm (7")	230 mm (9")
No load speed	8,500 min ⁻¹	6,600 min ⁻¹
Dimensions (L x W x H)	504 x 200 x 140 mm (19-7/8 x 7-7/8 x 5-1/2")	504 x 250 x 140 mm (19-7/8 x 9-7/8 x 5-1/2")
Net weight	5.93 - 6.43 kg (13.1 - 14.2 lbs.)	6.13 - 8.42 kg (13.5 - 18.6 lbs.)



SJS II Angle Grinder, Anti-Restart Function, Soft Start, Large Trigger Switch



	GA7061R	GA9061R
Continuous rating Input	2,200W	2,200W
Wheel diameter	180 mm (7")	230 mm (9")
No load speed	8,500 min ⁻¹	6,600 min ⁻¹
Dimensions (L x W x H)	450 x 200 x 145 mm (17-3/4 x 7-7/8 x 5-3/4")	450 x 250 x 145 mm (17-3/4 x 9-7/8 x 5-3/4")
Net weight	5.57 - 6.08 kg (12.3 - 13.4 lbs.)	5.68 - 8.04 kg (12.5 - 17.7 lbs.)



SJS II Angle Grinder, Large Trigger Switch



	GA7061
Continuous rating Input	2,200W
Wheel diameter	180 mm (7")
No load speed	8,500 min ⁻¹
Dimensions (L x W x H)	450 x 200 x 145 mm (17-3/4 x 7-7/8 x 5-3/4")
Net weight	5.53 - 6.04 kg (12.2 - 13.3 lbs.)



D-Handle Angle Grinder, Large Trigger Switch



	GA9062
Continuous rating Input	2,200W
Wheel diameter	230 mm (9")
No load speed	6,600 min ⁻¹
Dimensions (L x W x H)	450 x 250 x 144 mm (17-3/4 x 9-7/8 x 5-5/8")
Net weight	5.61 - 7.97 kg (12.4 - 17.6 lbs.)



Angle Grinder, Anti-Restart Function, Soft Start, Large Trigger Switch



GA9060R

Continuous rating Input	2,200W
Wheel diameter	230 mm (9")
No load speed	6,600 min ⁻¹
Dimensions (L x W x H)	450 x 250 x 144 mm (17-3/4 x 9-7/8 x 5-5/8")
Net weight	5.52 - 7.88 kg (12.8 - 17.4 lbs.)



High Torque Angle Grinder, Large Trigger Switch



GA7064

Continuous rating Input	2,200W
Wheel diameter	180 mm (7")
No load speed	6,600 min ⁻¹
Dimensions (L x W x H)	450 x 200 x 144 mm (17-3/4 x 7-7/8 x 5-5/8")
Net weight	5.34 - 5.85 kg (11.8 - 12.9 lbs.)

GA7060

Continuous rating Input	2,200W
Wheel diameter	180 mm (7")
No load speed	8,500 min ⁻¹
Dimensions (L x W x H)	450 x 200 x 144 mm (17-3/4 x 7-7/8 x 5-5/8")
Net weight	5.38 - 5.89 kg (11.9 - 13 lbs.)

GA9060

Continuous rating Input	2,200W
Wheel diameter	230 mm (9")
No load speed	6,600 min ⁻¹
Dimensions (L x W x H)	450 x 250 x 144 mm (17-3/4 x 9-7/8 x 5-5/8")
Net weight	5.5 - 7.86 kg (12.1 - 17.3 lbs.)



Angle Grinder, Large Trigger Switch



GA7090

Continuous rating input	2,200 W
Wheel diameter	180 mm (7")
No load speed	8,500 min ⁻¹
Cutting depth	69 mm (2-3/4")
Dimensions (L x W x H)	438 x 200 x 144 mm (17-1/4 x 7-7/8 x 5-5/8")
Net weight	5.1 - 7.3 kg (11.2 - 16.1 lbs.)

GA9090

Continuous rating input	2,200 W
Wheel diameter	230 mm (9")
No load speed	6,600 min ⁻¹
Cutting depth	69 mm (2-3/4")
Dimensions (L x W x H)	438 x 250 x 144 mm (17-1/4 x 9-7/8 x 5-5/8")
Net weight	5.3 - 7.4 kg (11.7 - 16.3 lbs.)



Angle Grinder, Anti-Restart Function, Soft Start, Large Trigger Switch



GA9020R

Continuous rating Input	2,200W
Wheel diameter	230 mm (9")
No load speed	6,600 min ⁻¹
Dimensions (L x W x H)	473 x 250 x 140 mm (18-5/8 x 9-7/8 x 5-1/2")
Net weight	5.8 - 8.09 kg (12.8 - 17.8 lbs.)



Angle Grinder, Large Trigger Switch



GA7020

Continuous rating Input	2,200W
Wheel diameter	180 mm (7")
No load speed	8,500 min ⁻¹
Dimensions (L x W x H)	473 x 200 x 140 mm (18-5/8 x 7-7/8 x 5-1/2")
Net weight	5.56 - 6.06 kg (12.26 - 13.36 lbs.)

GA9020

Continuous rating Input	2,200W
Wheel diameter	230 mm (9")
No load speed	6,600 min ⁻¹
Dimensions (L x W x H)	473 x 249 x 140 mm (18-5/8 x 9-3/4 x 5-1/2")
Net weight	5.76 - 8.05 kg (12.7 - 17.8 lbs.)



Angle Grinder, Soft Start, Large Trigger Switch



GA7020S

Continuous rating Input	2,200W
Wheel diameter	180 mm (7")
No load speed	8,500 min ⁻¹
Dimensions (L x W x H)	473 x 200 x 140 mm (18-5/8 x 7-7/8 x 5-1/2")
Net weight	5.69 - 6.19 kg (12.55 - 13.65 lbs.)

GA9020S

Continuous rating Input	2,200W
Wheel diameter	230 mm (9")
No load speed	6,600 min ⁻¹
Dimensions (L x W x H)	473 x 249 x 140 mm (18-5/8 x 9-3/4 x 5-1/2")
Net weight	5.85 - 8.14 kg (12.9 - 18 lbs.)



Angle Grinder, Anti-Restart Function, Soft Start, Large Trigger Switch



GA7050R

Continuous rating Input	2,000W
Wheel diameter	180 mm (7")
No load speed	8,500 min ⁻¹
Dimensions (L x W x H)	455 x 200 x 132 mm (17-7/8 x 7-7/8 x 5-3/16")
Net weight	4.66 - 5.18 kg (10.3 - 11.4 lbs.)

GA9050R

Continuous rating Input	2,000W
Wheel diameter	230 mm (9")
No load speed	6,600 min ⁻¹
Dimensions (L x W x H)	455 x 250 x 132 mm (17-7/8 x 9-7/8 x 5-3/16")
Net weight	4.82 - 7.12 kg (10.6 - 15.7 lbs.)



Grinding/Sanding/Polishing

Angle Grinder, Large Trigger Switch



	GA7050	GA9050
Continuous rating Input	2,000W	2,000W
Wheel diameter	180 mm (7")	230 mm (9")
No load speed	8,500 min ⁻¹	6,600 min ⁻¹
Dimensions (L x W x H)	432 x 200 x 132 mm (17 x 7-7/8 x 5-3/16")	432 x 250 x 132 mm (17 x 9-7/8 x 5-3/16")
Net weight	3.98 - 5 kg (8.8 - 11 lbs.)	4.64 - 6.94 kg (10.2 - 15.3 lbs.)

Angle Grinder, Anti-Restart Function, Soft Start, Large Trigger Switch



	GA7012C	GA9012C
Continuous rating Input	1,800W	1,800W
Wheel diameter	180 mm (7")	230 mm (9")
No load speed	8,400 min ⁻¹	6,000 min ⁻¹
Dimensions (L x W x H)	453 x 200 x 137 mm (17-7/8 x 7-7/8 x 5-3/8")	453 x 250 x 137 mm (17-7/8 x 9-7/8 x 5-3/8")
Net weight	4 - 4.5 kg (8.82 - 9.92 lbs.)	4.37 - 6.66 kg (9.6 - 14.7 lbs.)

Angle Grinder, Soft Start, Large Trigger Switch



	GA7010C	GA9010C
Continuous rating Input	1,800W	1,800W
Wheel diameter	180 mm (7")	230 mm (9")
No load speed	8,400 min ⁻¹	6,000 min ⁻¹
Dimensions (L x W x H)	453 x 200 x 137 mm (17-7/8 x 7-7/8 x 5-3/8")	453 x 250 x 137 mm (17-7/8 x 9-7/8 x 5-3/8")
Net weight	4.2 - 4.7 kg (9.26 - 10.36 lbs.)	4.36 - 6.65 kg (9.6 - 14.7 lbs.)



Comparison List

Model No.			No load speed (min ⁻¹)	Switch	AWS	BL motor	AFT	ADT	XPT	Brake	Anti-restart function	X-Lock
40Vmax Cordless Angle Grinder												
100mm	115mm	125mm										
GA003G	GA004G	GA005G	8,500	Slide	-	●	●	-	●	●	●	-
GA006G	GA007G	GA008G	8,500	Slide	-	●	●	-	●	-	●	-
GA011G	GA012G	GA013G	8,500	Paddle	-	●	●	-	●	●	●	-
GA014G	GA015G	GA016G	8,500	Paddle	-	●	●	-	●	-	●	-
GA021G	GA022G	GA023G	3,000 - 8,500	Slide	●	●	●	-	●	●	●	-
GA024G	GA025G	GA026G	3,000 - 8,500	Slide	●	●	●	-	●	-	●	-
GA027G	GA028G	GA029G	3,000 - 8,500	Paddle	●	●	●	-	●	●	●	-
GA030G	-	-	3,000 - 8,500	Paddle	●	●	●	-	●	-	●	-
GA039G	GA040G	GA041G	3,000 - 8,500	Slide	●	●	●	-	●	●	●	●
GA042G	GA043G	GA044G	3,000 - 8,500	Paddle	●	●	●	-	●	●	●	●
GA045G	GA046G	GA047G	8,500	Paddle	-	●	●	-	●	●	●	●
GA048G	GA049G	GA050G	11,000	Paddle	-	●	●	-	●	●	●	-
-	-	GA055G / GA056G	3,000 - 9,000	Slide / Paddle	-	●	●	-	●	●	●	-
150mm	180mm	230mm										
GA035G	-	-	8,500	Slide	-	●	●	-	●	●	●	-
GA036G	-	-	8,500	Paddle	-	●	●	-	●	●	●	-
-	GA037G	-	7,800	Large Trigger	●	●	●	-	●	●	●	-
-	-	GA038G	6,600	Large Trigger	●	●	●	-	●	●	●	-
GA051G	-	-	9,000	Paddle	-	●	●	-	●	●	●	-
18V x2 Cordless Angle Grinder												
180mm	230mm											
DGA700	-	-	7,800	Large Trigger	-	●	●	●	●	●	●	-
DGA701	-	-	7,800	Large Trigger	●	●	●	●	●	●	●	-
-	DGA900	-	6,000	Large Trigger	-	●	●	●	●	●	●	-
-	DGA901	-	6,000	Large Trigger	●	●	●	●	●	●	●	-
18V Cordless Angle Grinder												
100mm	115mm	125mm										
DGA414	-	DGA514	3,000 - 8,500	Slide	●	●	●	●	●	●	●	-
DGA413	DGA463	DGA513	3,000 - 8,500	Slide	-	●	●	●	●	●	●	-
DGA412	-	DGA512	3,000 - 8,500	Slide	●	●	●	●	●	-	●	-
DGA411	DGA461	DGA511	3,000 - 8,500	Slide	-	●	●	●	●	-	●	-
DGA406	DGA456	DGA506	8,500	Slide	-	●	●	●	●	●	●	-
DGA404	DGA454	DGA504	8,500	Slide	-	●	●	●	●	-	●	-
-	-	DGA521	8,500	Slide	-	●	●	●	●	-	●	●
DGA402	DGA452	-	11,000	Slide	-	-	-	-	-	-	●	-
DGA418	-	DGA518	3,000 - 8,500	Paddle	●	●	●	●	●	●	●	-
DGA417	DGA467	DGA517	3,000 - 8,500	Paddle	-	●	●	●	●	●	●	-
DGA419	DGA469	DGA519	3,000 - 8,500	Paddle	-	●	●	●	●	●	●	●
DGA408	DGA458	DGA508	8,500	Paddle	-	●	●	●	●	●	●	-
DGA405	DGA455	DGA505	8,500	Paddle	-	●	●	●	●	-	●	-
-	-	DGA520	8,500	Paddle	-	●	●	●	●	●	●	●

Comparison List

Model No.				Continuous rating Input	Switch	SJS / SJS2	Anti-restart function	Variable Speed	Constant Speed	AFT	Brake	Soft Start	X-Lock
Angle Grinder													
100mm	115mm	125mm	150mm										
-	GA4590	GA5090	-	1,900 W	Slide	SJS2	●	●	●	●	-	●	-
-	GA4591	GA5091	-	1,900 W	Slide	SJS2	●	●	●	●	●	●	-
-	GA4592	GA5092	-	1,900 W	Slide	SJS2	●	-	●	●	-	●	-
-	GA4593	GA5093	-	1,900 W	Paddle	SJS2	●	●	●	●	●	●	-
-	GA4594	GA5094	-	1,900 W	Paddle	SJS2	●	-	●	●	●	●	-
-	GA4595	GA5095	-	1,900 W	Paddle	SJS2	●	-	●	●	-	●	-
-	-	GA5021C	GA6021C	1,450 W	Large trigger	SJS	●	-	●	-	-	●	-
-	-	GA5020C	GA6020C	1,450 W	Finger trigger	SJS	●	-	●	-	-	●	-
-	-	GA5041C	-	1,400 W	Slide	SJS2	●	●	●	-	●	●	-
GA4040C	GA4540C	GA5040C	GA6040C	1,400 W	Slide	SJS2	●	●	●	-	-	●	-
-	GA4542C	GA5042C	GA6042C	1,400 W	Slide	SJS2	-	●	●	-	-	●	-
-	-	9565CVR	-	1,400 W	Slide	SJS	●	●	●	-	-	●	-
-	9564CV	9565CV	9566CV	1,400 W	Slide	SJS	-	●	●	-	-	●	-
-	-	9565CR	-	1,400 W	Slide	SJS	●	-	●	-	-	●	-
-	-	9565C	-	1,400 W	Slide	SJS	-	-	●	-	-	●	-
-	9564PCV	9565PCV	9566PCV	1,400 W	Paddle	SJS	-	●	●	-	-	●	-
-	9564PC	9565PC	9566PC	1,400 W	Paddle	SJS	-	-	●	-	-	●	-
-	-	GA5080 / GA5080R	-	1,400 W	Slide	SJS	●	-	●	-	-	●	●
GA4050	GA4550 / GA4552	GA5050 / GA5052	-	1,300 W	Paddle	-	-	-	-	-	-	-	-
GA4050R	GA4550R / GA4552R	GA5050R / GA5052R	-	1,300 W	Paddle	-	●	-	-	-	-	●	-
GA4051R	GA4551R / GA4553R	GA5051R / GA5053R	-	1,300 W	Paddle	-	●	-	-	-	-	●	-
-	GA4540R	GA5040R	GA6040R	1,100 W	Slide	SJS2	●	-	-	-	-	●	-
GA4040	GA4540	GA5040	GA6040	1,100 W	Slide	SJS2	-	-	-	-	-	-	-
-	-	9565HR	-	1,100 W	Slide	SJS	●	-	-	-	-	●	-
-	9564P	-	-	1,100 W	Paddle	SJS	-	-	-	-	-	-	-
-	-	GA5021	GA6021	1,050 W	Large trigger	SJS	-	-	-	-	-	-	-
-	-	GA5011	-	1,050 W	Large trigger	-	-	-	-	-	-	-	-
-	-	GA5010 / GA5020	GA6010 / GA6020	1,050 W	Finger trigger	- / SJS	-	-	-	-	-	-	-
GA4100	GA4600	GA5100	-	850 W	Slide	-	●	●	●	-	-	●	-
GA4570	-	-	-	840 W	Slide	-	-	-	-	-	-	-	●
9556HN	9557HN	9558HN	-	840 W	Slide	-	-	-	-	-	-	-	-
-	9557HNR	9558HNR	-	840 W	Slide	-	●	-	-	-	-	●	-
9556HP	9557HP	9558HP	-	840 W	Paddle	-	-	-	-	-	-	-	-
9556HB	-	-	-	840 W	Toggle	-	-	-	-	-	-	-	-
GA4031 / GA4032	-	-	-	720 W	Toggle	-	-	-	-	-	-	-	-
GA4030R	GA4530R	GA5030R	-	720 W	Slide	-	●	-	-	-	-	●	-
GA4030	GA4530	GA5030	-	720 W	Slide	-	-	-	-	-	-	-	-
GA4034	GA4534	GA5034	-	720 W	Paddle	-	-	-	-	-	-	-	-
9553HN	9554HN	9555HN	-	710 W	Slide	-	-	-	-	-	-	-	-
9553HB	-	-	-	710 W	Toggle	-	-	-	-	-	-	-	-
9500NB / N9500N	-	-	-	570 W	Toggle	-	-	-	-	-	-	-	-



Comparison List

Model No.		Continuous rating Input	Switch	SJS / SJS2	Anti-restart function	Constant Speed	AFT	Brake	Torque Limiter	Soft Start	X-Lock
180mm	230mm										
GA7070	GA9070	2,800 W	Large trigger	-	●	●	●	●	●	●	-
-	GA9071	2,800 W	Large trigger	-	●	●	●	●	●	●	-
GA7080 / GA7081	GA9080 / GA9081	2,700 W	Large trigger	-	●	-	-	-	●	●	-
GA7082	GA9082	2,700 W	Large trigger	-	-	-	-	-	●	-	-
GA7040S	GA9040S	2,600 W	Large trigger	-	-	-	-	-	●	●	-
-	GA9040	2,600 W	Large trigger	-	-	-	-	-	●	-	-
GA7030R	GA9030R	2,400 W	Large trigger	-	●	-	-	-	●	●	-
- / GA7030	GA9030S / GA9030	2,400 W	Large trigger	-	-	-	-	-	●	● / -	-
GA7031	GA9031	2,400 W	AC/DC trigger	-	-	-	-	-	●	-	-
GA7061R	GA9061R	2,200 W	Large trigger	SJS2	●	-	-	-	-	●	-
GA7061	-	2,200 W	Large trigger	SJS2	-	-	-	-	-	-	-
-	GA9060R / GA9062R	2,200 W	Large trigger	-	●	-	-	-	-	●	-
GA7060 / GA7064	GA9060	2,200 W	Large trigger	-	-	-	-	-	-	-	-
GA7090	GA9090	2,200 W	Large trigger	-	-	-	-	-	-	-	-
-	GA9020R	2,200 W	Large trigger	-	●	-	-	-	-	●	-
GA7020	GA9020	2,200 W	Large trigger	-	-	-	-	-	-	-	-
GA7020S	GA9020S	2,200 W	Large trigger	-	-	-	-	-	-	●	-
GA7050 / GA7050R	GA9050 / GA9050R	2,000 W	Large trigger	-	- / ●	-	-	-	-	- / ●	-
GA7012C	GA9012C	1,800 W	Large trigger	-	●	●	-	-	-	●	-
GA7010C	GA9010C	1,800 W	Large trigger	-	-	●	-	-	-	●	-



Grinding/Sanding/Polishing

180 mm (7") 1,600 W Variable Speed Angle Sander

SA7000C

Continuous rating Input	1,600W
Abrasive disc size	180 mm (7")
No load speed	1,500 - 4,000 min ⁻¹
Dimensions (L x W x H)	453 x 170 x 136 mm (17-7/8 x 6-11/16 x 5-3/8")
Net weight	3.5 - 3.6 kg (7.7 - 7.9 lbs.)



180 mm (7") 1,400 W Angle Sander

SA7000

Continuous rating Input	1,400W
Abrasive disc size	180 mm (7")
No load speed	5,000 min ⁻¹
Dimensions (L x W x H)	453 x 170 x 136 mm (17-7/8 x 6-11/16 x 5-3/8")
Net weight	3.5 - 3.6 kg (7.7 - 7.9 lbs.)



125 mm (5") 1,400 W SJS II Variable Speed Angle Sander, Anti-Restart Function

SA5040C

Continuous rating Input	1,400W
Wheel diameter	125 mm (5")
No load speed	2,000 - 7,800 min ⁻¹
Dimensions (L x W x H)	315 x 115 x 121 mm (12-3/8 x 4-1/2 x 4-3/4")
Net weight	2.5 - 3.7 kg (5.5 - 8.2 lbs.)



125 mm (5") 1,600 W Angle Sander

PK5011C

Continuous rating Input	1,600W
Wheel diameter	125 mm (5")
No load speed	2,000 - 5,500 min ⁻¹
Dimensions (L x W x H)	468 x 159 x 155 mm (18-1/2 x 6-1/4 x 6-1/8")
Net weight	4.3 - 4.4 kg (9.5 - 9.7 lbs.)



180 mm (7") 900 W Variable Speed Disc Sander

GV7000C

Continuous rating Input	900W
Abrasive disc size	180 mm (7")
Capacity	Pad: 180 mm (7")
No load speed	2,500 - 4,700 min ⁻¹
Overall length	210 mm (8-1/4")
Net weight	2.1 kg (4.6 lbs.)



180 mm (7") 550 W Disc Sander

GV7000

Continuous rating Input	550W
Abrasive disc size	180 mm (7")
Capacity	Pad: 180 mm (7")
No load speed	4,700 min ⁻¹
Overall length	210 mm (8-1/4")
Net weight	2.1 kg (4.7 lbs.)



150 mm (6") 440 W Disc Sander

GV6010

Continuous rating Input	440W
Abrasive disc size	150 mm (6")
Capacity	Pad: 120 mm (4-3/4")
No load speed	4,500 min ⁻¹
Dimensions (L x W x H)	200 x 74 x 181 mm (7-7/8 x 2-15/16 x 7-1/8")
Net weight	1.2 kg (2.6 lbs.)



125 mm (5") 440 W Disc Sander

GV5010

Continuous rating Input	440W
Abrasive disc size	125 mm (5")
Capacity	Pad: 120 mm (4-3/4")
No load speed	4,500 min ⁻¹
Dimensions (L x W x H)	200 x 74 x 181 mm (7-7/8 x 2-15/16 x 7-1/8")
Net weight	1.2 kg (2.6 lbs.)



40Vmax XGT BL Brushless Cordless 180mm (7") Polisher

PV001G

40V max

Brush pad capacity	180 mm (7")
Pad diameter	165 mm (6-1/2")
No load speed	by Trigger: 0 - 2,200 min ⁻¹ by Dial: 600 - 2,200 min ⁻¹
Dimensions (L x W x H)	w/ BL4080F: 550 x 196 x 195 mm (21-5/8 x 7-3/4 x 7-5/8")
Net weight	3.0 - 4.4 kg (6.6 - 9.7 lbs.)



Grinding/Sanding/Polishing

Grinding/
Sanding/
Polishing

180 mm (7") 1,200 W Variable Speed Polisher

9237CB

Continuous rating Input	1,200W
Capacity	Wool bonnet: 180 mm (7") Curved blade design: 180 mm (7")
No load speed	0 - 3,200 min ⁻¹
Dimensions (L x W x H)	431 x 198 x 187 mm (17 x 7-3/4 x 7-3/8")
Net weight	3.2 - 3.4 kg (7 - 7.5 lbs.)



180 mm (7") 1,200 W Variable Speed Polisher

9237C

Continuous rating Input	1,200W
Capacity	Wool bonnet: 180 mm (7") Curved blade design: 180 mm (7")
No load speed	0 - 3,200 min ⁻¹
Dimensions (L x W x H)	431 x 198 x 187 mm (17 x 7-3/4 x 7-3/8")
Net weight	3.4 kg (7.5 lbs.)



180 mm (7") 900 W Variable 2-Speed Vertical Polisher

PV7000C

Continuous rating Input	900W
Capacity	Pad: 180 mm (7") Wool bonnet: 180 mm (7")
No load speed	600 - 2,100 min ⁻¹
Overall length	210 mm (8-1/4")
Net weight	2.1 kg (4.6 lbs.)



180 mm (7") 900 W Variable 2-Speed Vertical Polisher

PV7001C

Continuous rating Input	900W
Capacity	Pad: 180 mm (7") Wool bonnet: 180 mm (7")
No load speed	600 - 2,000 min ⁻¹
Overall length	210 mm (8-1/4")
Net weight	2.1 - 2.2 kg (4.6 - 4.9 lbs.)



18V LXT BL Cordless Sander Polisher

DPV300

18V



Pad / disc diameter	Twist-on / Twist-off style: 50 mm (2") Hook & Loop Style: 80 mm (3-1/8")
Backing pad diameter	Twist-on / Twist-off style: 46 mm (1-13/16") Hook & Loop style: 75 mm (2-15/16")
Brush pad capacity	80 mm (3-1/8")
Disc paper diameter	50 mm (2")
No load speed	Polishing: 0 - 2,800 min ⁻¹ Sanding: 0 - 9,500 min ⁻¹
Head length	127 mm (5")
Dimensions (L x W x H)	w/ BL1830B / BL1840B / BL1850B / BL1860B:
Net weight	160 x 79 x 256 mm (6-5/16 x 3-1/8 x 10-1/8") 1.3 - 1.6 kg (2.9 - 3.5 lbs.)



12Vmax CXT BL Cordless Sander Polisher

PV301D

12V max



Pad / disc diameter	Twist-on / Twist-off style: 50 mm (2") Hook & Loop Style: 80 mm (3-1/8")
Backing pad diameter	Twist-on / Twist-off style: 46 mm (1-13/16") Hook & Loop style: 75 mm (2-15/16")
Brush pad capacity	80 mm (3-1/8")
Disc paper diameter	50 mm (2")
No load speed	Polishing: 0 - 2,800 min ⁻¹ Sanding: 0 - 9,500 min ⁻¹
Head length	127 mm (5")
Dimensions (L x W x H)	w/ BL1041B: 139 x 67 x 249 mm (5-1/2 x 2-5/8 x 9-3/4")
Net weight	1.1 - 1.2 kg (2.4 - 2.6 lbs.)



125 mm (5") 900 W Stone Polisher

PW5000C

Continuous rating Input	900W
Wheel diameter	100 - 125 mm (4 - 5")
No load speed	2,000 - 4,000 min ⁻¹
Overall length	313 mm (12-3/8")
Net weight	2.3 - 2.6 kg (5.1 - 5.7 lbs.)



100 mm (4") 900 W Stone Polisher

PW5001C

Continuous rating Input	900W
Wheel diameter	100 mm (4")
No load speed	2,000 - 4,000 min ⁻¹
Overall length	359 mm (14-1/8")
Net weight	2.3 - 2.6 kg (5.1 - 5.7 lbs.)



Grinding/Sanding/Polishing

40Vmax XGT Li-Ion BL motor AFT Cordless 8 mm (1/4") Die Grinder, Paddle switch

GD002G

40V max

new



Collet size	3 / - / 6 / - / 8 mm (- / 1/8 / - / 1/4 / - / ")
Max wheel diameter	Wheel points: 32 mm (1-1/4") Cut-off wheel: 52 mm (2-1/16")
No load speed	7,000 - 29,000 min ⁻¹
Circumference of grip portion	146 mm (5-3/4")
Dimensions (L x W x H)	452 x 85 x 119 mm (17-3/4 x 3-3/8 x 4-11/16")
Net weight	2.2 - 3.4 kg (4.9 - 7.5 lbs.)

XGT BL MOTOR AFT XPT



40Vmax XGT Li-Ion BL motor AFT Cordless 8 mm (1/4") Die Grinder, Slide Switch with Lock-on function

GD001G

40V max

new



Collet size	3 / - / 6 / - / 8 mm (- / 1/8 / - / 1/4 / - / ")
Max wheel diameter	Wheel points: 32 mm (1-1/4") Cut-off wheel: 52 mm (2-1/16")
No load speed	7,000 - 29,000 min ⁻¹
Circumference of grip portion	146 mm (5-3/4")
Dimensions (L x W x H)	452 x 85 x 119 mm (17-3/4 x 3-3/8 x 4-11/16")
Net weight	2.2 - 3.4 kg (4.9 - 7.5 lbs.)

XGT BL MOTOR AFT XPT



18V LXT Li-Ion Cordless 8 mm (1/4") Die Grinder

DGD800

18V



Collet size	3 / - / 6 / - / 8 mm (- / 1/8 / - / 1/4 / - / ")
Wheel diameter	36 mm (1-7/16")
No load speed	26,000 min ⁻¹
Mandrel (shank) length	46 mm
Dimensions (L x W x H)	402 x 82 x 118 mm (15-3/4 x 3-1/4 x 4-5/8")
Net weight	1.7-2.2 kg (3.8-4.9 lbs.)

LXT



18V LXT Li-Ion Cordless 8 mm (1/4") Die Grinder

DGD801

18V



Collet size	3 / - / 6 / - / 8 mm (- / 1/8 / - / 1/4 / - / ")
Wheel diameter	36 mm (1-7/16")
No load speed	26,000 min ⁻¹
Mandrel (shank) length	46 mm
Dimensions (L x W x H)	307 x 82 x 118 mm (12-1/8 x 3-1/4 x 4-5/8")
Net weight	1.5-2 kg (3.3-4.3 lbs.)

LXT



8 mm (1/4") 750 W SJS Variable Speed Die Grinder, Slide Switch

GD0810C



Continuous rating Input	750W
Collet size	3 / - / 6 / - / 8 mm (- / 1/8 / - / 1/4 / - / ")
Wheel diameter	50 mm (2")
No load speed	7,000 min ⁻¹
Overall length	371 mm (14-5/8")
Net weight	1.9 kg (4.2 lbs.)

SJS



8 mm (1/4") 750 W SJS High Torque Variable Speed Die Grinder, Paddle Switch

GD0811C



Continuous rating Input	750W
Collet size	3 / - / 6 / - / 8 mm (- / 1/8 / - / 1/4 / - / ")
Wheel diameter	50 mm (2")
No load speed	7,000 min ⁻¹
Dimensions (L x W x H)	390 x 75 x 88 mm (15-3/8 x 2-15/16 x 3-1/2")
Net weight	1.99 - 2 kg (4.39 - 4.41 lbs.)

SJS



8 mm (1/4") 750 W SJS Variable Speed Die Grinder, Slide Switch

GD0800C



Continuous rating Input	750W
Collet size	3 / - / 6 / - / 8 mm (- / 1/8 / - / 1/4 / - / ")
Wheel diameter	25 mm (1")
No load speed	7,000 - 28,000 min ⁻¹
Dimensions (L x W x H)	371 x 75 x 75 mm (14-5/8 x 2-15/16 x 2-15/16")
Net weight	1.6 kg (3.5 lbs.)

SJS



8 mm (1/4") 750 W SJS Variable Speed Die Grinder, Paddle Switch

GD0801C



Continuous rating Input	750W
Collet size	- / 8 mm (1/4 / - / ")
Wheel diameter	25 mm
No load speed	29,000 min ⁻¹
Dimensions (L x W x H)	390 x 75 x 88 mm (15-3/8 x 2-15/16 x 3-1/2")
Net weight	1.96 - 1.97 kg (4.32 - 4.34 lbs.)

SJS



8 mm (1/4") 500 W SJS Die Grinder

GD0800



Continuous rating Input	500W
Collet size	3 / - / 6 / - / 8 mm (- / 1/8 / - / 1/4 / - / ")
Wheel diameter	25 mm (1")
No load speed	28,000 min ⁻¹
Dimensions (L x W x H)	371 x 75 x 75 mm (14-5/8 x 2-15/16 x 2-15/16")
Net weight	1.78 kg (3.92 lbs.)

SJS



6 mm (1/4") 400 W Die Grinder

GD0601



Continuous rating Input	400W
Collet size	3 / - / 6 / - / mm (- / 1/8 / - / 1/4 / - / ")
Wheel diameter	38 mm (1-1/2")
No load speed	25,000 min ⁻¹
Dimensions (L x W x H)	359 x 82 x 82 mm (14-1/8 x 3-1/4 x 3-1/4")
Net weight	1.68 - 1.84 kg (3.7 - 4.06 lbs.)



Grinding/Sanding/Polishing

6 mm (1/4") 400 W Die Grinder

GD0602



Continuous rating Input	400W
Collet size	3 / - / 6 / - / 8 mm (- / 1/8 / - / 1/4")
Wheel diameter	38 mm (1-1/2")
No load speed	25,000 min ⁻¹
Dimensions (L x W x H)	264 x 82 x 82 mm (10-3/8 x 3-1/4 x 3-1/4")
Net weight	1.41 - 1.57 kg (3.11 - 3.46 lbs.)



6 mm (1/4") 400 W Die Grinder

GD0600



Continuous rating Input	400W
Collet size	3 / - / 6 / - mm (- / 1/8 / - / 1/4")
Wheel diameter	38 mm (1-1/2")
No load speed	25,000 min ⁻¹
Dimensions (L x W x H)	358 x 82 x 82 mm (14-1/8 x 3-1/4 x 3-1/4")
Net weight	1.71 - 1.87 kg (3.77 - 4.12 lbs.)



6 mm (1/4") 240 W Die Grinder

GD0603



Continuous rating Input	240W
Collet size	6 / - mm (- / 1/4")
Wheel diameter	23 mm
No load speed	28,000 min ⁻¹
Diameter of grip	65 mm
Circumference of grip portion	203 mm
Dimensions (L x W x H)	289 x 64 x 67 mm (11-3/8 x 2-1/2 x 2-5/8")
Net weight	0.97 kg (2.1 lbs.)



150 mm (6") 750 W Straight Grinder

GS6000



Continuous rating Input	750W
Wheel diameter	150 mm (6")
Hole diameter	12.7, 20 mm (13/16")
No load speed	5,600 min ⁻¹
Dimensions (L x W x H)	590 x 216 x 130 mm (23-1/4 x 8-1/2 x 5-1/8")
Net weight	5.2 - 5.4 kg (11.4 - 12 lbs.)



125 mm (5") 750 W Straight Grinder

GS5000



Continuous rating Input	750W
Wheel diameter	125 mm (5")
Hole diameter	12.7, 20 mm (13/16")
No load speed	5,600 min ⁻¹
Dimensions (L x W x H)	590 x 189 x 116 mm (23-1/4 x 7-7/16 x 4-9/16")
Net weight	5 - 5.2 kg (11 - 11.5 lbs.)



205 mm (8") 550 W Bench Grinder

GB801



Continuous rating Input	550W
Wheel diameter	205 mm (8")
Wheel width	19 mm (3/4")
Hole diameter	15.88 mm (5/8")
H.P.	3/4
No load speed	2,850 min ⁻¹ (50 Hz) / 3,450 min ⁻¹ (60 Hz)
Dimensions (L x W x H)	395 x 265 x 333 mm (15-9/16 x 10-7/16 x 13-7/64")
Net weight	20.5 kg (45.2 lbs.)



150 mm (6") 250 W Bench Grinder

GB602W



Continuous rating Input	250W
Wheel diameter	150 mm (6")
Wheel width	6.4 mm (1/4") / 16 mm (5/8")
Hole diameter	12.7 mm (1/2")
H.P.	1/3
No load speed	2,850 min ⁻¹ (50 Hz) / 3,450 min ⁻¹ (60 Hz)
Dimensions (L x W x H)	375 x 348 x 286 mm (14-49/64 x 13-45/64 x 11-17/64")
Net weight	9.5 kg (20.9 lbs.)



150 mm (6") 250 W Bench Grinder

GB602



Continuous rating Input	250W
Wheel diameter	150 mm (6")
Wheel width	16 mm (5/8")
Hole diameter	12.7 mm (1/2")
H.P.	1/3
No load speed	2,850 min ⁻¹ (50 Hz) / 3,450 min ⁻¹ (60 Hz)
Dimensions (L x W x H)	375 x 205 x 286 mm (14-49/64 x 8 x 11-17/64")
Net weight	9.4 kg (20.7 lbs.)



18V LXT BL Brushless Cordless 150 mm (6") Random Orbit Polisher

DPO600



Pad size	150 mm (6")
Orbits per minute	Normal mode: 0 - 6,800 min ⁻¹ Finishing mode: 0 - 5,200 min ⁻¹
Strokes per minute	Normal mode: 0 - 13,600 min ⁻¹ Finishing mode: 0 - 10,400 min ⁻¹
No load speed	Normal mode: 0 - 780 min ⁻¹ Finishing mode: 0 - 600 min ⁻¹
Orbit diameter	5.5 mm (7/32")
Dimensions (L x W x H)	530 x 148 x 126 mm (20-7/8 x 5-7/8 x 5")
Net weight	3.1 - 3.6 kg (6.9 - 7.9 lbs.)



18V LXT BL Brushless Cordless 125 mm (5") Random Orbit Polisher

DPO500



Pad size	125 mm (5")
Orbits per minute	Normal mode: 0 - 6,800 min ⁻¹ Finishing mode: 0 - 5,200 min ⁻¹
Strokes per minute	Normal mode: 0 - 13,600 min ⁻¹ Finishing mode: 0 - 10,400 min ⁻¹
No load speed	Normal mode: 0 - 780 min ⁻¹ Finishing mode: 0 - 600 min ⁻¹
Orbit diameter	5.5 mm (7/32")
Dimensions (L x W x H)	530 x 123 x 134 mm (20-7/8 x 4-7/8 x 5-1/4")
Net weight	3.1 - 3.6 kg (6.9 - 7.9 lbs.)



Grinding/Sanding/Polishing

150 mm (6") 900 W Random Orbit Polisher

PO6000C

Continuous rating Input	900W
Pad size	150 mm (6")
Orbits per minute	0 - 6,800 min ⁻¹
Strokes per minute	0 - 13,600 min ⁻¹
No load speed	0 - 780 min ⁻¹
Orbit diameter	5.5 mm (7/32")
Dimensions (L x W x H)	451 x 148 x 126 mm (17-3/4 x 5-7/8 x 5")
Net weight	2.8 - 3 kg (6.2 - 6.5 lbs.)



125 mm (5") 900 W Random Orbit Polisher

PO5000C

Continuous rating Input	900W
Pad size	125 mm (5")
Orbits per minute	0 - 6,800 min ⁻¹
Strokes per minute	0 - 13,600 min ⁻¹
No load speed	0 - 780 min ⁻¹
Orbit diameter	5.5 mm (7/32")
Dimensions (L x W x H)	451 x 123 x 134 mm (17-3/4 x 4-7/8 x 5-1/4")
Net weight	2.8 - 3 kg (6.2 - 6.5 lbs.)



40Vmax XGT BL AWS 125 mm (5") Battery Powered Variable Speed Random Orbit Sander with Built-In Dust Extraction System

BO001CG

Orbits per minute	6,000 - 10,000 min ⁻¹
Orbit diameter	5.0 mm (3/16")
Abrasive disc size	125 mm (5")
Dimensions (L x W x H)	234 x 123 x 96 mm (9-1/4 x 4-7/8 x 3-3/4")
Net weight (Tool only)	0.92 kg (2.0 lbs.)

40V max



XGT MOTOR BL AWS XPT



40Vmax XGT BL AWS 150 mm (6") Battery Powered Variable Speed Random Orbit Sander with Built-In Dust Extraction System

BO002CG

Orbits per minute	6,000 - 10,000 min ⁻¹
Orbit diameter	5.0 mm (3/16")
Abrasive disc size	150 mm (6")
Dimensions (L x W x H)	247 x 148 x 96 mm (9-3/4 x 5-7/8 x 3-3/4")
Net weight (Tool only)	0.98 kg (2.2 lbs.)

40V max



XGT MOTOR BL AWS XPT



40Vmax XGT BL AWS 125 mm (5") Battery Powered Variable Speed Random Orbit Sander with Built-In Dust Extraction System

BO003CG

Orbits per minute	6,000 - 10,000 min ⁻¹
Orbit diameter	3.0 mm (1/8")
Abrasive disc size	125 mm (5")
Dimensions (L x W x H)	233 x 123 x 96 mm (9-1/8 x 4-7/8 x 3-3/4")
Net weight (Tool only)	0.91 kg (2.0 lbs.)

40V max



XGT MOTOR BL AWS XPT



40Vmax XGT BL AWS 150 mm (6") Battery Powered Variable Speed Random Orbit Sander with Built-In Dust Extraction System

BO004CG

Orbits per minute	6,000 - 10,000 min ⁻¹
Orbit diameter	3.0 mm (1/8")
Abrasive disc size	150 mm (6")
Dimensions (L x W x H)	246 x 148 x 96 mm (9-11/16 x 5-7/8 x 3-3/4")
Net weight (Tool only)	0.96 kg (2.1 lbs.)

40V max



XGT MOTOR BL AWS XPT



40Vmax XGT BL AWS 80 x 130 mm (3-1/8" x 5-1/8") Battery Powered Variable Speed Orbital Sander with Built-In Dust Extraction System

BO005CG

Orbits per minute	6,000 - 10,000 min ⁻¹
Orbit diameter	3.0 mm (1/8")
Pad size	80 x 130 mm (3-1/8 x 5-1/8")
Abrasive paper size	Square: 80 x 130 mm (3-1/8 x 5-1/8") Triangular: 100 x 150 mm (3-15/16 x 5-7/8")
Dimensions (L x W x H)	236 x 80 x 99 mm (9-1/4 x 3-1/8 x 3-7/8")
Net weight (Tool only)	0.93 kg (2.1 lbs.)

40V max



XGT MOTOR BL AWS XPT



40Vmax XGT BL AWS 100 x 150 mm (3-15/16" x 5-7/8") Battery Powered Variable Speed Orbital Sander with Built-In Dust Extraction System

BO006CG

Orbits per minute	6,000 - 10,000 min ⁻¹
Orbit diameter	3.0 mm (1/8")
Abrasive paper size	Square: 80 x 130 mm (3-1/8 x 5-1/8") Triangular: 100 x 150 mm (3-15/16 x 5-7/8")
Dimensions (L x W x H)	263 x 100 x 99 mm (10-3/8 x 3-15/16 x 3-7/8")
Net weight (Tool only)	0.93 kg (2.1 lbs.)

40V max



XGT MOTOR BL AWS XPT



40Vmax XGT BL AWS 1/3 Sheet Battery Powered Variable Speed Orbital Sander with Built-In Dust Extraction System

BO007CG

Orbits per minute	6,000 - 12,000 min ⁻¹
Orbit diameter	2.0 mm (1/16")
Pad size	93 x 185 mm (3-5/8 x 7-1/4")
Abrasive paper size	93 x 228 mm (3-5/8 x 9")
Clamp type	
Dimensions (L x W x H)	263 x 92 x 106 mm (10-3/8 x 3-5/8 x 4-3/16")
Net weight (Tool only)	1.1 kg (2.4 lbs.)

40V max



XGT MOTOR BL AWS XPT



18V LXT Li-Ion 125 mm (5") Cordless 3-Speed Random Orbit Sander with Built-In Dust Extraction System

DBO180

18V



Pad diameter	123 mm (4-7/8")
Abrasive disc size	125 mm (5")
Orbits per minute	7,000 / 9,500 / 11,000 min ⁻¹
Dimensions (L x W x H)	175 x 123 x 153 mm (6-7/8 x 4-7/8 x 6")
Net weight	1.4 - 1.7 kg (3 - 3.7 lbs.)



150 mm (6") 750 W Variable Speed Random Orbit Sander with Soft Start

BO6050



Continuous rating Input	750W
Pad diameter	150 mm (6")
Abrasive disc size	150 mm (6")
Orbits per minute	1,600 - 6,800 min ⁻¹
Sanding strokes per minute	3,200 - 13,600 min ⁻¹
Pad speed in Roto-orbit mode	140 - 600 min ⁻¹
Orbit diameter	5.5 mm (7/32")
Dimensions (L x W x H)	330 x 155 x 145 mm (13 x 6-1/8 x 5-3/4")
Net weight	2.6 kg (5.7 lbs.)



150 mm (6") 310 W Variable Speed Random Orbit Sander with Built-In Dust Extraction System

BO6030



Continuous rating Input	310W
Pad diameter	150 mm (6")
Abrasive disc size	150 mm (6")
Orbits per minute	4,000 - 10,000 min ⁻¹
Orbit diameter	3.0 mm (1/8")
Overall length	309 mm (12-1/8")
Net weight	2.4 kg (5.2 lbs.)



125 mm (5") 300 W Variable Speed Random Orbit Sander with Built-In Dust Extraction System

BO5041



Continuous rating Input	300W
Pad diameter	123 mm (4-7/8")
Abrasive disc size	125 mm (5")
Orbits per minute	4,000 - 12,000 min ⁻¹
Dimensions (L x W x H)	218 x 123 x 153 mm (8-5/8 x 4-7/8 x 6")
Net weight	1.4 kg (3.1 lbs.)



125 mm (5") 300 W Variable Speed Random Orbit Sander with Built-In Dust Extraction System

BO5031



Continuous rating Input	300W
Pad diameter	123 mm (4-7/8")
Abrasive disc size	125 mm (5")
Orbits per minute	4,000 - 12,000 min ⁻¹
Dimensions (L x W x H)	153 x 123 x 153 mm (6 x 4-7/8 x 6")
Net weight	1.3 kg (3 lbs.)



125 mm (5") 300 W Random Orbit Sander with Built-In Dust Extraction System

BO5040



Continuous rating Input	300W
Pad diameter	123 mm (4-7/8")
Abrasive disc size	125 mm (5")
Orbits per minute	12,000 min ⁻¹
Dimensions (L x W x H)	218 x 123 x 153 mm (8-5/8 x 4-7/8 x 6")
Net weight	1.4 kg (3.1 lbs.)



125 mm (5") 300 W Random Orbit Sander with Built-In Dust Extraction System

BO5030



Continuous rating Input	300W
Pad diameter	123 mm (4-7/8")
Abrasive disc size	125 mm (5")
Orbits per minute	12,000 min ⁻¹
Dimensions (L x W x H)	153 x 123 x 153 mm (6 x 4-7/8 x 6")
Net weight	1.3 kg (2.9 lbs.)



1/2 Sheet 600 W Finishing Sander

9046



Continuous rating Input	600W
Pad size	115 x 229 mm (4-1/2 x 9")
Abrasive paper size	115 x 280 mm (4-1/2 x 11")
Orbits per minute	6,000 min ⁻¹
Overall length	283 mm (11-1/8")
Orbit diameter	5 mm (3/16")
Net weight	3.0 kg (6.6 lbs.)



18V LXT Li-Ion 1/4 Sheet Cordless Finishing Sander

DBO480

18V



Orbits per minute	High: 14,000 min ⁻¹ / Low: 11,000 min ⁻¹
Strokes per minute	High: 28,000 min ⁻¹ / Low: 22,000 min ⁻¹
Orbit diameter	1.5 mm (1/16")
Abrasive paper size	Hook & Loop type: 114 x 102 mm (4-1/2 x 4") Clamp type: 140 x 114 mm (5-1/2 x 4-1/2")
Compatible Hook & Loop paper size	Square: 114 x 102 mm (4-1/2 x 4") Rectangular: 114 x 190 mm (4-1/2 x 7-1/2") Triangular: 96 x 96 mm (3-3/4 x 3-3/4")
Pad size	112 x 102 mm (4-3/8 x 4")
Dimensions (L x W x H)	w/ BL1830B / BL1840B / BL1850B / BL1860B: 171 x 112 x 152 mm (6-3/4 x 4-3/8 x 6")
Net weight	1.4 - 1.7 kg (3.1 - 3.8 lbs.)



18V LXT Li-Ion 1/4 Sheet Cordless Finishing Sander

DBO481

18V



Orbits per minute	High: 14,000 min ⁻¹ / Low: 11,000 min ⁻¹
Strokes per minute	High: 28,000 min ⁻¹ / Low: 22,000 min ⁻¹
Orbit diameter	1.5 mm (1/16")
Abrasive paper size	Clamp type: 140 x 114 mm (5-1/2 x 4-1/2")
Compatible Hook & Loop paper size	Square: 114 x 102 mm (4-1/2 x 4") Rectangular: 114 x 190 mm (4-1/2 x 7-1/2") Triangular: 96 x 96 mm (3-3/4 x 3-3/4")
Pad size	112 x 102 mm (4-3/8 x 4")
Dimensions (L x W x H)	w/ BL1830B / BL1840B / BL1850B / BL1860B: 171 x 112 x 151 mm (6-3/4 x 4-3/8 x 5-15/16")
Net weight	1.4 - 1.7 kg (3.1 - 3.8 lbs.)



Grinding/Sanding/Polishing

18V LXT Li-Ion 1/4 Sheet Cordless Finishing Sander

DBO482

18V

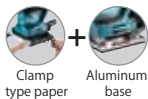
Clamp
type paper Aluminum
base

Orbits per minute	High: 14,000 min ⁻¹ / Low: 11,000 min ⁻¹
Strokes per minute	High: 28,000 min ⁻¹ / Low: 22,000 min ⁻¹
Orbit diameter	1.5 mm (1/16")
Abrasive paper size	Clamp type: 140 x 114 mm (5-1/2 x 4-1/2")
Compatible Hook & Loop paper size	Square: 114 x 102 mm (4-1/2 x 4") Rectangular: 114 x 190 mm (4-1/2 x 7-1/2") Triangular: 96 x 96 mm (3-3/4 x 3-3/4")
Pad size	112 x 102 mm (4-3/8 x 4")
Dimensions (L x W x H)	w/ BL1830B / BL1840B / BL1850B / BL1860B: 171 x 112 x 150 mm (6-3/4 x 4-3/8 x 5-7/8")
Net weight	1.4 - 1.8 kg (3.1 - 4.0 lbs.)

LXT



18V LXT Li-Ion 1/4 Sheet Cordless Finishing Sander

DBO484

18V

Hook & loop or Clamp
type paper Aluminum
base

Orbits per minute	High: 14,000 min ⁻¹ / Low: 11,000 min ⁻¹
Strokes per minute	High: 28,000 min ⁻¹ / Low: 22,000 min ⁻¹
Orbit diameter	1.5 mm (1/16")
Abrasive paper size	Hook & Loop type: 114 x 102 mm (4-1/2 x 4") Clamp type: 140 x 114 mm (5-1/2 x 4-1/2")
Compatible Hook & Loop paper size	Square: 114 - 102 mm (4-1/2 - 4") Rectangular: 114 - 190 mm (4-1/2 - 7-1/2") Triangular: 96 - 96 mm (3-3/4 - 3-3/4")
Pad size	112 x 102 mm (4-3/8 x 4")
Dimensions (L x W x H)	w/ BL1830B / BL1840B / BL1850B / BL1860B: 171 x 112 x 151 mm (6-3/4 x 4-3/8 x 5-15/16")
Net weight	1.4 - 1.8 kg (3.1 - 4.0 lbs.)

LXT



18V BL 1/3 Sheet Cordless Finishing Sander with Built-In Dust Extraction System

DBO380

18V

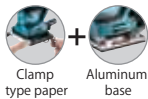
Clamp
type paper Aluminum
base

Orbits per minute	4,000 / 8,000 / 12,000 min ⁻¹
Strokes per minute	8,000 / 16,000 / 24,000 min ⁻¹
Orbit diameter	2.0 mm (1/16")
Abrasive paper size	Rectangular: 93 x 228 mm (3-5/8 x 9")
Pad size	93 x 185 mm (3-5/8 x 7-1/4")
Dimensions (L x W x H)	w/ BL1830B / BL1840B / BL1850B / BL1860B: 336 x 92 x 169 mm (13-1/4 x 3-5/8 x 6-5/8")
Net weight	1.9 - 2.2 kg (4.2 - 4.9 lbs.)

LXT BL MOTOR XPT



18V BL AWS 1/3 Sheet Cordless Finishing Sander with Built-In Dust Extraction System

DBO381

18V

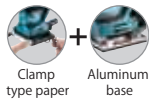
Clamp
type paper Aluminum
base

Orbits per minute	4,000 / 8,000 / 12,000 min ⁻¹
Strokes per minute	8,000 / 16,000 / 24,000 min ⁻¹
Orbit diameter	2.0 mm (1/16")
Abrasive paper size	Rectangular: 93 x 228 mm (3-5/8 x 9")
Pad size	93 x 185 mm (3-5/8 x 7-1/4")
Dimensions (L x W x H)	w/ BL1830B / BL1840B / BL1850B / BL1860B: 336 x 92 x 169 mm (13-1/4 x 3-5/8 x 6-5/8")
Net weight	1.9 - 2.2 kg (4.2 - 4.9 lbs.)

LXT BL AWS MOTOR XPT



18V BL 1/3 Sheet Cordless Finishing Sander with Built-In Dust Extraction System

DBO382

18V

Hook & loop or Clamp
type paper Aluminum
base

Orbits per minute	4,000 / 8,000 / 12,000 min ⁻¹
Strokes per minute	8,000 / 16,000 / 24,000 min ⁻¹
Orbit diameter	2.0 mm (1/16")
Abrasive paper size	Hook & Loop type: 93 x 185 mm (3-5/8 x 7-1/4") Clamp type: 93 x 228 mm (3-5/8 x 9")
Pad size	93 x 185 mm (3-5/8 x 7-1/4")
Dimensions (L x W x H)	w/ BL1830B / BL1840B / BL1850B / BL1860B: 336 x 92 x 169 mm (13-1/4 x 3-5/8 x 6-5/8")
Net weight	1.9 - 2.2 kg (4.2 - 4.9 lbs.)

LXT BL MOTOR XPT



1/2 Sheet 330 W Variable Speed Finishing Sander

BO4900V



Continuous rating Input	330W
Orbits per minute	4,000 - 10,000 min ⁻¹
Strokes per minute	8,000 - 20,000 min ⁻¹
Abrasive paper size	115 x 232 mm (4-1/2 x 9-1/8")
Pad size	229 x 115 mm (9 x 4-1/2")
Overall length	289 mm (11-3/8")
Net weight	2.8 kg (6.2 lbs.)



1/2 Sheet 330 W Finishing Sander

BO4900



Continuous rating Input	330W
Orbits per minute	10,000 min ⁻¹
Strokes per minute	20,000 min ⁻¹
Abrasive paper size	115 x 232 mm (4-1/2 x 9-1/8")
Pad size	229 x 115 mm (9 x 4-1/2")
Overall length	289 mm (11-3/8")
Net weight	2.9 kg (6.4 lbs.)



1/2 Sheet 330 W Finishing Sander

BO4901



Continuous rating Input	330W
Orbits per minute	10,000 min ⁻¹
Strokes per minute	20,000 min ⁻¹
Abrasive paper size	115 x 280 mm (4-1/2 x 11")
Pad size	229 x 115 mm (9 x 4-1/2")
Overall length	289 mm (11-3/8")
Net weight	2.8 kg (6.2 lbs.)



1/4 Sheet 200 W Finishing Sander

BO4556

Continuous rating Input	200W
Orbits per minute	14,000 min ⁻¹
Abrasive paper size	114 x 140 mm (4-1/2 x 5-1/2")
Pad size	102 x 112 mm (4 x 4-3/8")
Dimensions (L x W x H)	131 x 112 x 141 mm (5-1/8 x 4-3/8 x 5-9/16")
Net weight	1.1 kg (2.5 lbs.)



1/4 Sheet 200 W Finishing Sander

BO4555

Continuous rating Input	200W
Orbits per minute	14,000 min ⁻¹
Abrasive paper size	114 x 102 mm (4-1/2 x 4")
Pad size	102 x 112 mm (4 x 4-3/8")
Dimensions (L x W x H)	131 x 112 x 142 mm (5-1/8 x 4-3/8 x 5-5/8")
Net weight	1.1 kg (2.4 lbs.)



1/4 Sheet 200 W Finishing Sander

BO4558

Continuous rating Input	200W
Orbits per minute	14,000 min ⁻¹
Abrasive paper size	114 x 140 mm (4-1/2 x 5-1/2")
Pad size	102 x 112 mm (4 x 4-3/8")
Dimensions (L x W x H)	131 x 112 x 141 mm (5-1/8 x 4-3/8 x 5-9/16")
Net weight	1.2 kg (2.5 lbs.)



112 x 190 mm (4-3/8" x 7-1/2") 200 W Finishing Sander

BO4565

Continuous rating Input	200W
Orbits per minute	14,000 min ⁻¹
Abrasive paper size	114 x 102 mm (4-1/2 x 4")
Pad size	112 x 190 mm (4-3/8 x 7-1/2")
Dimensions (L x W x H)	219 x 112 x 139 mm (8-5/8 x 4-3/8 x 5-1/2")
Net weight	1.1 kg (2.4 lbs.)



100 x 164 mm (3-15/16" x 6-1/2") 200 W Finishing Sander

BO4566

Continuous rating Input	200W
Orbits per minute	14,000 min ⁻¹
Abrasive paper size	102 x 166 mm (4 x 6-1/2")
Pad size	164 x 100 mm (6-1/2 x 3-15/16")
Dimensions (L x W x H)	197 x 100 x 137 mm (7-3/4 x 3-15/16 x 5-3/8")
Net weight	1.2 kg (2.6 lbs.)



1/3 Sheet 190 W Variable Speed Finishing Sander with Built-In Dust Extraction System

BO3711

Continuous rating Input	190W
Orbits per minute	4,000 - 11,000 min ⁻¹
Strokes per minute	8,000 - 22,000 min ⁻¹
Orbit diameter	2.0 mm (1/16")
Abrasive paper size	93 x 228 mm (3-5/8 x 9")
Pad size	185 x 93 mm (7-1/4 x 3-5/8")
Dimensions (L x W x H)	253 x 92 x 154 mm (10 x 3-5/8 x 6-1/16")
Net weight	1.6 kg (3.5 lbs.)



1/3 Sheet 190 W Finishing Sander with Built-In Dust Extraction System

BO3710

Continuous rating Input	190W
Orbits per minute	11,000 min ⁻¹
Strokes per minute	22,000 min ⁻¹
Orbit diameter	2.0 mm (1/16")
Abrasive paper size	93 x 228 mm (3-5/8 x 9")
Pad size	185 x 93 mm (7-1/4 x 3-5/8")
Dimensions (L x W x H)	253 x 92 x 154 mm (10 x 3-5/8 x 6-1/16")
Net weight	1.6 kg (3.5 lbs.)



1/4 Sheet 180 W Finishing Sander

BO4557

Continuous rating Input	180W
Orbits per minute	14,000 min ⁻¹
Abrasive paper size	114 x 140 mm (4-1/2 x 5-1/2")
Pad size	102 x 112 mm (4 x 4-3/8")
Dimensions (L x W x H)	131 x 112 x 137 mm (5-1/8 x 4-3/8 x 5-3/8")
Net weight	1 kg (2.1 lbs.)



1/3 Sheet 180 W Finishing Sander

9035H

Continuous rating Input	180W
Orbits per minute	11,000 min ⁻¹
Abrasive paper size	93 x 228 mm (3-5/8 x 9")
Pad size	185 x 93 mm (7-1/4 x 3-5/8")
Dimensions (L x W x H)	236 x 93 x 146 mm (9-1/4 x 3-5/8 x 5-3/4")
Net weight	1.5 kg (3.3 lbs.)



1/4 Sheet 170 W Finishing Sander

BO4510H

Continuous rating Input	170W
Orbits per minute	12,000 min ⁻¹
Abrasive paper size	114 x 140 mm (4-1/2 x 5-1/2")
Pad size	100 x 110 mm (3-15/16 x 4-5/16")
Dimensions (L x W x H)	116 x 110 x 129 mm (4-9/16 x 4-5/16 x 5-1/8")
Net weight	1.1 kg (2.4 lbs.)



Grinding/Sanding/Polishing

18V LXT BL AWS Cordless 225 mm (8-7/8") Variable Speed Drywall Sander

DSL801

18V



Abrasive disc size	225 mm (8-7/8")
Pad diameter	210 mm (8-1/4")
No load speed	1,000 - 1,800 min ⁻¹
Dimensions (L x W x H)	1,120 - 1,540 x 278 x 273 mm (44 - 60-1/2 x 11 x 10-3/4")
Net weight	4.6 - 5.8 kg (10.1 - 12.8 lbs.)

LXT BL AWS XPT



40Vmax XGT BL AWS 76 mm x 533 mm (3" x 21") Cordless Variable Speed Belt Sander with Anti-restart function

BS001G

40V max



Belt width	76 mm (3")
Belt length	533 mm (21")
Belt speed	120 - 470 m/min (390 - 1,540 ft/min)
Dimensions (L x W x H)	440 x 148 x 165 mm (17-1/4 x 5-7/8 x 6-1/2")
Net weight	4.5 - 5.1 kg (9.9 - 11.2 lbs.)

XGT BL AWS XPT



18V LXT BL 9 mm x 533 mm (3/8" x 21") Variable Speed Belt Sander

DBS180

18V



Belt width	6 / 9 / 13 mm (1/4 / 3/8 / 1/2")
Belt length	533 mm (21")
Belt speed	600 - 1,700 m/min (1,970 - 5,600 ft/min)
Dimensions (L x W x H)	w/ BL1830B / BL1840B / BL1850B / BL1860B: 500 x 96 x 116 mm (19-3/4 x 3-3/4 x 4-9/16")
Net weight	1.8 - 2.1 kg (4.0 - 4.6 lbs.)

LXT BL



100 mm x 610 mm (4" x 24") 1,200 W Belt Sander

9403



Continuous rating Input	1,200W
Belt width	100 mm (4")
Belt length	610 mm (24")
Belt speed	500 m/min (1,640 ft/min)
Overall length	353 mm (13-7/8")
Net weight	5.9 kg (13 lbs.)



100 mm x 610 mm (4" x 24") 1,010 W Variable Speed Belt Sander

9404



Continuous rating Input	1,010W
Belt width	100 mm (4")
Belt length	610 mm (24")
Belt speed	210 - 440 m/min (690 - 1,440 ft/min)
Overall length	334 mm (13-1/8")
Net weight	4.7 kg (10.3 lbs.)



76 mm x 610 mm (3" x 24") 1,010 W Variable Speed Belt Sander

9920



Continuous rating Input	1,010W
Belt width	76 mm (3")
Belt length	610 mm (24")
Belt speed	210 - 440 m/min (690 - 1,440 ft/min)
Overall length	334 mm (13-1/8")
Net weight	4.5 kg (9.9 lbs.)



76 mm x 610 mm (3" x 24") 850 W Belt Sander

9924DB



Continuous rating Input	850W
Belt width	76 mm (3")
Belt length	610 - 620 mm (24 - 24 - 3/8")
Belt speed	400 m/min (1,300 ft/min)
Overall length	355 mm (14")
Net weight	4.8 kg (10.6 lbs.)



76 mm x 533 mm (3" x 21") 1,010 W Variable Speed Belt Sander

9903



Continuous rating Input	1,010W
Belt width	76 mm (3")
Belt length	533 mm (21")
Belt speed	210 - 440 m/min (690 - 1,440 ft/min)
Overall length	296 mm (11-5/8")
Net weight	4.3 kg (9.5 lbs.)



76 mm x 457 mm (3" x 18") 650 W Variable Speed Belt Sander

9911



Continuous rating Input	650W
Belt width	76 mm (3")
Belt length	457 mm (18")
Belt speed	75 - 270 m/min (250 - 900 ft/min)
Overall length	262 mm (10-3/8")
Net weight	2.6 kg (5.7 lbs.)



Grinding/Sanding/Polishing

76 mm x 457 mm (3" x 18") 650 W Belt Sander

9910

Continuous rating Input	650W
Belt width	76 mm (3")
Belt length	457 mm (18")
Belt speed	270 m/min (900 ft/min)
Overall length	262 mm (10-5/16")
Net weight	2.7 kg (6 lbs.)



30 mm x 533 mm (1-3/16" x 21") 520 W Variable Speed Belt Sander

9031

Continuous rating Input	520W
Belt width	30 mm (1-3/16")
Belt length	533 mm (21")
Belt speed	200 - 1,000 m/min (656 - 3,280 ft/min)
Overall length	380 mm (15")
Net weight	2.1 kg (4.6 lbs.)



9 mm x 533 mm (3/8" x 21") 500 W Variable Speed Belt Sander

9032

Continuous rating Input	500W
Belt width	6 - 13 mm (1/4 - 1/2")
Belt length	533 mm (21")
Belt speed	300 - 1,700 m/min (980 - 5,600 ft/min)
Max sanding depth	110 mm (4-5/16")
Overall length	420 mm (16-1/2")
Net weight	1.6 kg (3.5 lbs.)



100 x 120 mm (4" x 4-3/4") Wheel Sander

9741

Continuous rating Input	860W
Wheel diameter	100 x 120 mm (4 x 4-3/4")
No load speed	3,500 min ⁻¹
Overall length	310 mm (12-1/4")
Net weight	4.2 kg (9.3 lbs.)



Cutting

Icon



Double Insulation



Constant Speed



Dust Collection



Variable Speed



Soft Start



Toolless blade change



Brake



Bevel Cutting 45 left



Built-in Job Light



Reversing



Orbital Cutting



Carrying Case



Anti-restart function



Bayonet Shank Jig Saw Blade

18V LXT BL AWS ADT Cordless 125 mm (5") Cutter, Dry Type

DCC500

18V



Wheel diameter	125 mm (5")
Hole diameter	20 mm (13/16")
Max cutting capacity	0°: 40 mm (1-9/16") 45°: 27 mm (1-1/16")
No load speed	8,800 min ⁻¹
Dimensions (L x W x H)	w/ BL1830B / BL1840B / BL1850B / BL1860B: 283 x 158 x 172 mm (11-1/8 x 6-1/4 x 6-3/4")
Net weight	2.5 - 3.0 kg (5.5 - 6.6 lbs.)

LXT BL ADT AWS XPT



18V LXT BL AWS ADT Cordless 125 mm (5") Cutter, Wet Type

DCC501

18V



Wheel diameter	125 mm (5")
Hole diameter	20 mm (13/16")
Max cutting capacity	0°: 40 mm (1-9/16") 45°: 27 mm (1-1/16")
No load speed	8,800 min ⁻¹
Dimensions (L x W x H)	w/ Water supply tank, w/ BL1830B / BL1840B / BL1850B / BL1860B: 283 x 163 x 291 mm (11-1/8 x 6-3/8 x 11-1/2")
Net weight	2.7 - 3.0 kg (6.0 - 6.6 lbs.)

LXT BL ADT AWS XPT



12V max CXT Li-Ion Cordless 85 mm (3-3/8") Cutter, Wet Type

CC301D

12V max



Wheel diameter	85 mm (3-3/8")
Hole diameter	15 mm (9/16")
Max cutting capacity	0°: 25.5 mm (1") 45°: 16.5 mm (5/8")
No load speed	1,600 min ⁻¹
Tank capacity	0.5 L
Dimensions (L x W x H)	313 x 170 x 125 mm (12-3/8 x 6-11/16 x 4-7/8")
Net weight	1.9 kg (4.1 lbs.)

CXT



125 mm (5") 1,400 W Dustless Cutter, Dry Type

4100KB



Continuous rating	1,400W
Input	
Wheel diameter	125 mm (5")
Hole diameter	20 mm (13/16")
Max cutting capacity	40.0 mm (1-9/16")
No load speed	12,200 min ⁻¹
Dimensions (L x W x H)	231 x 220 x 179 mm (9-1/8 x 8-5/8 x 7")
Net weight	3 kg (6.6 lbs.)



110 mm (4-3/8") 1,300 W Cutter, Dry / Wet Type (country-specific)

4100NH3



Continuous rating	1,300W
Input	
Wheel diameter	110 mm (4-3/8")
Max cutting capacity	0°: 32 mm (1-1/4")
No load speed	13,800 min ⁻¹
Dimensions (L x W x H)	227 x 209 x 166 mm (8-15/16 x 8-1/4 x 6-1/2")
Net weight	2.8 kg (6.2 lbs.)



110 mm (4-3/8"), 125 mm (5") 1,400 W Cutter, Dry / Wet Type (country-specific)

4100NH2



Continuous rating	1,400W
Input	
Wheel diameter	110 - 125 mm (4-3/8" - 5")
Max cutting capacity	0°: 32.5 mm (1-1/4") w/ 110mm (4-3/8") wheel 45°: 21.5 mm (7/8")
No load speed	12,200 min ⁻¹
Dimensions (L x W x H)	238 x 214 x 169 mm (9-3/8 x 8-3/8 x 6-5/8")
Net weight	3 kg (6.6 lbs.)



125 mm (5") 860 W Cutter

4101RH



Continuous rating	860W
Input	
Wheel diameter	125 mm (5")
Max cutting capacity	0°: 41.5 mm (1-5/8") 45°: 26 mm (1")
No load speed	12,000 min ⁻¹
Overall length	236 mm (9-5/16")
Net weight	3 kg (11.5 lbs.)



180 mm (7-1/8") 1,400 W Cutter

4107R



Continuous rating	1,400W
Input	
Capacity	Max cutting: 60 mm (2-3/8")
Wheel diameter	180 mm (7-1/8")
Hole diameter	25/25.4 mm (1/1")
No load speed	5,000 min ⁻¹
Overall length	370 mm (14-9/16")
Net weight	6.3 kg (14.5 lbs.)



Cutting

110 mm (4-3/8") 1,450 W Cutter with Roller Base

4100NH2R



Continuous rating	1,450W
Input	
Wheel diameter	110 mm (4-3/8")
Max cutting capacity	45°: 24.5 mm (15/16")
	48°: 23.5 mm (15/16")
No load speed	12,200 min ⁻¹
Dimensions (L x W x H)	398 x 365 x 267 mm (15-5/8 x 14-3/8 x 10-1/2")
Net weight	6.5 kg (14.2 lbs.)

Roller base



110 mm (4-3/8") 1,450 W Cutter with Wet Cutting Base

4100NH2W



Continuous rating	1,450W
Input	
Wheel diameter	110 mm (4-3/8")
Max cutting capacity	45°: 24.5 mm (15/16")
	48°: 23.5 mm (15/16")
No load speed	12,200 min ⁻¹
Dimensions (L x W x H)	398 x 365 x 267 mm (15-5/8 x 14-3/8 x 10-1/2")
Net weight	6.3 kg (13.8 lbs.)

Wet cutting base



40Vmax XGT BL Cordless 185 mm (7-1/4") Metal Cutter with Electric Brake, Twin LED Lights

CS002G

40V max



Wheel diameter	185 mm (7-1/4")
Max cutting capacity	0°: 67 mm (2-5/8")
No load speed	3,500 min ⁻¹
Dimensions (L x W x H)	350 x 232 x 270 mm (13-3/4 x 9-1/8 x 10-5/8")
Net weight	4.2 - 5.4 kg (9.3 - 11.9 lbs.)



18V LXT BL ADT Cordless 150 mm (5-7/8") Metal Cutter, Electric Brake, Soft Start, Dual LED Lights

DCS553

18V



Wheel diameter	150 mm (5-7/8")
Max cutting capacity	0°: 57.5 mm (2-1/4")
No load speed	4,200 min ⁻¹
Dimensions (L x W x H)	267 x 186 x 250 mm (10-1/2 x 7-3/8 x 9-7/8")
Net weight	2.8 - 3.1 kg (6.1 - 6.8 lbs.)



18V LXT Li-Ion Cordless 136 mm (5-3/8") Metal Cutter with Dust Box, Electric Brake, Dual LED Lights

DCS552

18V



Wheel diameter	136 mm (5-3/8")
Max cutting capacity	0°: 50.5 mm (2")
No load speed	3,600 min ⁻¹
Dimensions (L x W x H)	348 x 196 x 203 mm (13-3/4 x 7-3/4 x 8")
Net weight	2.4 - 2.7 kg (5.3 - 6.0 lbs.)



185 mm (7-1/4") 1,100 W Metal Cutter

4131



Continuous rating	1,100W
Input	
Wheel diameter	185 mm (7-1/4")
Hole diameter	15.88 / 20 / 30 mm (5/8 / 13/16 / 1-3/16")
Capacity	Max cutting: 63 mm (2-1/2")
No load speed	3,500 min ⁻¹
Overall length	358 mm (14-1/8")
Net weight	4.8 kg (11.3 lbs.)



305 mm (12") 1,750 W Metal Cutting Saw

LC1230



Continuous rating	1,750W
Input	
Wheel diameter	305 mm (12")
Hole diameter	25.4 mm (1")
Max cutting capacity	0°: 115 mm (4-1/2")
	45°: 90 mm (3-1/2")
No load speed	1,300 min ⁻¹
Dimensions (L x W x H)	516 x 306 x 603 mm (20-1/4 x 12 x 23-3/4")
Net weight	19.3 kg (42.5 lbs.)



40Vmax X2 (80Vmax) XGT BL AFT AWS Cordless 355 mm (14") Power Cutter, Electric Brake

CE002G

40V max x2



Wheel diameter	355 mm (14")
Max cutting capacity	127 mm (5")
No load speed	4,200 min ⁻¹
Dimensions (L x W x H)	825 x 272 x 487 mm (32-1/2 x 10-3/4 x 19-1/4")
Net weight	13.1 - 15.1 kg (28.9 - 33.3 lbs.)



40Vmax X2 (80Vmax) XGT BL AFT Cordless 355 mm (14") Power Cutter, Electric Brake

CE001G

40V max x2



Wheel diameter	355 mm (14")
Max cutting capacity	127 mm (5")
No load speed	5,300 min ⁻¹
Dimensions (L x W x H)	w/ BL4080F: 786 x 283 x 433 mm (31 x 11-1/8 x 17")
Net weight	12.3 - 14.1 kg (27.1 - 31.1 lbs.)



40Vmax XGT BL AFT Cordless 305 mm (12") Power Cutter, Electric Brake

CE004G

40V max



Wheel diameter	305 mm (12")
Max cutting capacity	121 mm (4-3/4")
No load speed	5,000 min ⁻¹
Dimensions (L x W x H)	663 x 240 x 406 mm (26-1/8 x 9-1/2 x 16")
Net weight	6.7 - 7.7 kg (14.8 - 17.0 lbs.)



Cutting

40Vmax XGT BL AFT Cordless 230 mm (9") Power Cutter, Electric Brake

CE003G

40V max



Wheel diameter	230 mm (9")
Max cutting capacity	88 mm (3-1/2")
No load speed	6,600 min ⁻¹
Dimensions (L x W x H)	603 x 240 x 350 mm (23-3/4 x 9-1/2 x 13-3/4")
Net weight	6.4 - 7.4 kg (14.1 - 16.3 lbs.)

XGT BL AFT XPT



18V X2 (36V) LXT BL AFT Cordless 230 mm (9") Power Cutter, Electric Brake

DCE090

18V x2



Wheel diameter	230 mm (9")
Max cutting capacity	88 mm (3-1/2")
No load speed	6,600 min ⁻¹
Dimensions (L x W x H)	554 x 241 x 283 mm (21-3/4 x 9-1/2 x 11-1/8")
Net weight	5.6 - 6.3 kg (12.3 - 13.9 lbs.)

LXT BL AFT XPT



355 mm (14") 2,400 W SJS Angle Cutter with Soft Start

4114S



Continuous rating	2,400W
Input	
Wheel diameter	355 mm (14")
Capacity	Max cutting: 125 mm (5")
No load speed	3,500 min ⁻¹
Dimensions (L x W x H)	673 x 240 x 329 mm (26-1/2 x 9-1/2 x 13")
Net weight	10.8 kg (23.9 lbs.)



355 mm (14") 1,650 W SJS Angle Cutter

4114



Continuous rating	1,650W
Input	
Wheel diameter	355 mm (14")
Capacity	Max cutting: 125 mm (5")
No load speed	3,500 min ⁻¹
Dimensions (L x W x H)	673 x 240 x 329 mm (26-1/2 x 9-1/2 x 13")
Net weight	12 kg (26.5 lbs.)



125 mm (5") 1,400 W SJS Wall Chaser with Soft Start

SG1251



Continuous rating	1,400W
Input	
Blade diameter	125 mm (5")
Capacity	Depth: 0 - 30 mm (0 - 1-3/16") Width: 6 - 30 mm (1/4 - 1-3/16")
No load speed	10,000 min ⁻¹
Dimensions (L x W x H)	350 x 151 x 178 mm (13-3/4 x 5-15/16 x 7")
Net weight	4.3 kg (9.5 lbs.)



118 mm (4-5/8") 1,300 W Variable Speed Aluminum Groove Cutter, Mechanical Brake, Soft Start

CA5000



Continuous rating	1,300W
Input	
Wheel diameter	118 mm (4-5/8")
Hole diameter	20 mm (13/16")
Max cutting capacity w/ Cutter blade	w/ Guide rail: 11 mm (7/16")
Max cutting capacity w/ TCT Saw blade	w/ Guide rail: 36 mm (1-7/16") w/o Guide rail: 41 mm (1-5/8")
No load speed	2,200 - 6,400 min ⁻¹
Dimensions (L x W x H)	346 x 250 x 250 mm (13-5/8 x 9-7/8 x 9-7/8")
Net weight	4.7 kg (10.4 lbs.)



18V X2 (36V) LXT BL 355 mm (14") Toolless Portable Cut-Off

DLW140

18V x2



Wheel diameter	355 mm (14")
Hole diameter	25.4 mm (1")
Capacity at 0°	Round: 127 mm (5")
Capacity at 45°	Round: 127 mm (5") Rectangular: 115 x 103 mm (4-1/2 x 4-1/16")
Capacity at 90°	Rectangular: 115, 102, 70 x 130, 194, 233 mm (4-1/2, 4, 2-3/4 x 5-1/8, 7-5/8, 9-1/8")
Dimensions (L x W x H)	w/ European type safety guard: 537 x 290 x 640 mm (21-1/8 x 11-3/8 x 25-1/4")
Net weight	17.2 - 17.8 kg (37.9 - 39.3 lbs.)



405 mm (16") 1,430 W Portable Cut-Off

2416S



Continuous rating	1,430W
Input	
Wheel diameter	405 mm (16")
Hole diameter	25.4 mm (1")
No load speed	2,300 min ⁻¹
Dimensions (L x W x H)	610 x 265 x 535 mm (24 x 10-3/8 x 21")
Net weight	19.2 kg (42.3 lbs.)

355 mm (14") 2,200 W Toolless Portable Cut-Off

LW1400



Continuous rating	2,200W
Input	
Wheel diameter	355 mm (14")
Hole diameter	25.4 mm (1")
Capacity at 0°	Round: 127 mm (5")
Capacity at 45°	Round: 127 mm (5") Rectangular: 115 x 103 mm (4-1/2 x 4-1/16")
Capacity at 90°	Rectangular: 115, 102, 70 x 233, 194, 130 mm (4-1/2, 4, 2-3/4 x 9-1/8, 7-5/8, 5-1/8")
No load speed	3,800 min ⁻¹
Dimensions (L x W x H)	530 x 295 x 640 mm (20-7/8 x 11-5/8 x 25-1/4")
Net weight	18.7 kg (41.2 lbs.)



355 mm (14") 2,200 W Portable Cut-Off

LW1401



Continuous rating	2,200W
Input	
Wheel diameter	355 mm (14")
Hole diameter	25.4 mm (1")
Capacity at 0°	Round: 127 mm (5")
Capacity at 45°	Round: 127 mm (5") Rectangular: 115 x 103 mm (4-1/2 x 4-1/16")
Capacity at 90°	Rectangular: 115, 102, 70 x 130, 194, 233 mm (4-1/2, 4, 2-3/4 x 5-1/8, 7-5/8, 9-1/8")
No load speed	3,800 min ⁻¹
Dimensions (L x W x H)	500 x 295 x 640 mm (19-3/4 x 11-5/8 x 25-1/4")
Net weight	18.3 kg (40.3 lbs.)



Cutting

40Vmax XGT BL Cordless 16 mm (5/8") Steel Rod Cutter

SC001G

40V max

new



Cutting capacity	Dia.: 3 - 16 mm (1/8 - 5/8")
Cutting speed (sec)	1.7
Maximum number of cuts	(ϕ 16mm rebar): 250
Dimensions (L x W x H)	321 x 103 x 285 mm (12-5/8 x 4-1/16 x 11-1/4")
Net weight	6.0 - 7.2 kg (13.2 - 15.9 lbs.)



18V LXT BL ADT Cordless 25 mm (1") Steel Rod Cutter

DSC251

18V



Blade diameter	110 mm (4-5/16")
Cutting capacity	Dia.: 10 - 25 mm (3/8 - 1")
No load speed	2,200 min ⁻¹
Dimensions (L x W x H)	471 x 137 x 139 mm (18-1/2 x 5-25/64 x 5-15/32")
Net weight	4.0 kg (8.8 lbs.)



18V LXT Li-Ion Cordless 20 mm (3/4") Steel Rod Cutter

DSC191

18V



Cutting capacity	Dia.: 3 - 20 mm (1/8 - 3/4")
Cutting speed (sec)	6.5
Dimensions (L x W x H)	412 x 212 x 284 mm (16-1/5 x 8-3/8 x 11-1/8")
Net weight	11.1 - 11.2 kg (24.5 - 24.6 lbs.)



18V LXT BL Brushless Cordless 16 mm (5/8") Steel Rod Cutter

DSC163

18V



Cutting capacity	Dia.: 3 - 16 mm (1/8 - 5/8")
Cutting speed (sec)	2.8
Dimensions (L x W x H)	360 x 108 x 276 mm (14-1/8 x 4-1/4 x 10-7/8")
Net weight	6.9 kg (15.2 lbs.)



18V LXT BL Brushless Cordless Threaded Rod Cutter

DSC121

18V



Capacity	Steel: 8 - 12 mm (5/16 - 1/2")
Cutting speed (sec)	3.0
Dimensions (L x W x H)	w/ BL1830B / BL1840B / BL1850B / BL1860B: 212 x 323 x 260 mm (8-3/8 x 12-3/4 x 10-1/4")
Net weight	6.0 kg (13.2 lbs.)



18V LXT BL Brushless Cordless Threaded Rod Cutter

DSC102

18V



Capacity	Mild steel: W3/8, M10, M8, M6 Stainless steel: W3/8, M8, M6
Min. cutting length	20 mm (13/16")
Dimensions (L x W x H)	w/ BL1830B / BL1840B / BL1850B / BL1860B: 199 x 103 x 308 mm (7-7/8 x 4-1/16 x 12-1/8")
Net weight	2.8 - 3.2 kg (6.2 - 7 lbs.)



12Vmax CXT BL Brushless Cordless Threaded Rod Cutter

SC103D

12V max



Max cutting capacity	Mild steel: M10 Stainless steel: W3/8
Min. cutting length	20 mm (13/16")
Dimensions (L x W x H)	w/ BL1041B: 180 x 107 x 289 mm (7-1/8 x 4-1/4 x 11-3/8")
Net weight	2.7 - 2.8 kg (6.0 - 6.2 lbs.)



18V LXT BL AFT Cordless 76 mm (3") Compact Cut Off

DMC300

18V



Wheel diameter	76 mm (3")
Hole diameter	9.5, 10.0 mm (3/8, 13/32")
Wheel plate thickness	1.0 mm (1/32")
Max cutting capacity	w/ Dust cover attachment: 13.5 mm (1/2") w/o Dust cover attachment: 16.0 mm (5/8")
No load speed	20,000 min ⁻¹
Dimensions (L x W x H)	w/ BL1830B / BL1840B / BL1850B / BL1860B: 271 x 104 x 182 mm (10-5/8 x 4-1/8 x 7-1/8")
Net weight	1.2 - 1.7 kg (2.6 - 3.7 lbs.)



12V max CXT Li-Ion Cordless Multi Cutter

CP100D

12V max



Max cutting capacity	6 mm (1/4")
No load speed	300 min ⁻¹
Dimensions (L x W x H)	w/ BL1041B: 291 x 66 x 121 mm (11-1/2 x 2-5/8 x 4-3/4")
Net weight	0.72 - 0.88 kg (1.6 - 1.9 lbs.)



Cutting

40Vmax XGT BL Cordless Variable Speed Portable Band Saw

PB002G

40V max



Capacity	Round: 127 mm (5") Square: 127 x 127 mm (5 x 5")
Blade speed	0 - 3.2 m/s (0 - 630 ft/min.)
Blade size	Length: 1,140 mm (45") Width: 13 mm (1/2") Thickness: 0.5 mm (0.02")
Dimensions (L x W x H)	w/ BL4080F: 510 x 218 x 346 mm (20 x 8-5/8 x 13-5/8")
Net weight	6.6 - 7.8 kg (14.6 - 17.2 lbs.)

XGT BL MOTOR XPT



18V LXT Li-Ion Cordless Variable Speed Portable Band Saw

DPB180

18V



Capacity	Round: 120 mm (4-3/4") Rectangular: 120 x 120 mm (4-3/4 x 4-3/4")
Blade speed	1.4 - 2.7 m/s (275 - 530 ft/min.)
Blade size	Length: 1,140 mm (44-7/8") Width: 13 mm (1/2") Thickness: 0.5 mm (0.02")
Dimensions (L x W x H)	523 x 231 x 313 mm (20-5/8 x 9-1/8 x 12-3/8")
Net weight	6.8 - 7.1 kg (14.9 - 15.7 lbs.)

LXT



18V LXT BL Cordless Variable Speed Portable Band Saw

DPB183

18V



Capacity	Round: 66 mm (2-5/8") Square: 66 x 66 mm (2-5/8 x 2-5/8")
Blade speed	0 - 3.2 m/s (0 - 630 ft/min.)
Blade size	Length: 835 mm (32-7/8") Width: 13 mm (1/2") Thickness: 0.5 mm (0.02")
Dimensions (L x W x H)	392 x 174 x 242 mm (15-1/2 x 6-7/8 x 9-1/2")
Net weight	3.6 - 3.9 kg (7.9 - 8.6 lbs.)

LXT BL MOTOR



18V LXT Li-Ion Cordless Portable Band Saw

DPB182

18V



Capacity	Round: 64 mm (2-1/2") Rectangular: 64 x 64 mm (2-1/2 x 2-1/2")
Blade speed	3.2 m/s (630 ft/min.)
Blade size	Length: 835 mm (32-7/8") Width: 13 mm (1/2") Thickness: 0.5 mm (0.02")
Dimensions (L x W x H)	477 x 197 x 229 mm (18-3/4 x 7-3/4 x 9")
Net weight	3.8 - 4.1 kg (8.3 - 9.0 lbs.)

LXT



18V LXT BL Cordless Portable Band Saw

DPB184

18V



Capacity	Round: 51 mm (2") Square: 51 x 51 mm (2 x 2")
Blade speed	0 - 3.2 m/s (0 - 630 ft/min.)
Blade size	Length: 730 mm (28-3/4") Width: 13 mm (1/2") Thickness: 0.5 mm (0.02")
Dimensions (L x W x H)	w/ BL1830B / BL1840B / BL1850B / BL1860B: 373 x 162 x 223 mm (14-3/4 x 6-3/8 x 8-3/4")
Net weight	3.3 - 3.6 kg (7.3 - 7.9 lbs.)

LXT BL MOTOR



120 x 120 mm (4-3/4" x 4-3/4") 710 W Variable Speed Portable Band Saw with Light

2107F

18V



Continuous rating Input	710W
Capacity	Round: 120 mm (4-3/4") Rectangular: 120 x 120 mm (4-3/4 x 4-3/4")
Blade speed	1.0 - 1.7 m/s
Blade size	Length: 1,140 mm Width: 13 mm Thickness: 0.5 mm
Dimensions (L x W x H)	508 x 188 x 256 mm (20 x 7-3/8 x 10-1/8")
Net weight	6.3 kg (13.9 lbs.)



40Vmax XGT BL Cordless Hole Puncher

PP001G

40V max



Capacity	Steel: 20 mm Stainless steel: 20 mm
Dimensions (L x W x H)	w/ BL4020 / BL4025: 398 x 129 x 315 mm (15-5/8 x 5-1/8 x 12-3/8")
Net weight	11.6 - 12.8 kg (25.6 - 28.2 lbs.)

XGT BL MOTOR



18V LXT Li-Ion Cordless Hole Puncher

DPP200

18V



Capacity	Steel: 20 mm (13/16") Stainless steel: 20 mm (13/16")
Max throat depth	40 mm (1-9/16")
Dimensions (L x W x H)	w/ BL1830B / BL1840B / BL1850B / BL1860B: 417 x 127 x 315 mm (16-3/8 x 5 x 12-3/8")
Net weight	10.5 kg (23.2 lbs.)

LXT

18V LXT BL Cordless 2.0 mm (14 Ga) Metal Shear

DJS200

18V



Max cutting capacity	Steel: 2.0 mm (14 gauge) Stainless steel: 1.6 mm (16 gauge)
Strokes per minute	0 - 3,000 min ⁻¹
Dimensions (L x W x H)	w/ BL1830B / BL1840B / BL1850B / BL1860B: 345 x 79 x 207 mm (13-5/8 x 3-1/8 x 8-1/8")
Net weight	2.2 - 2.5 kg (4.9 - 5.5 lbs.)

LXT BL MOTOR XPT



18V LXT BL Cordless 1.3 mm (18 Ga) Metal Shear

DJS131

18V



Max cutting capacity	Steel: 1.3 mm (18 gauge) Stainless steel: 1.0 mm (20 gauge)
Strokes per minute	0 - 3,000 min ⁻¹
Dimensions (L x W x H)	w/ BL1830B / BL1840B / BL1850B / BL1860B: 332 x 79 x 252 mm (13-1/8 x 3-1/8 x 9-7/8")
Net weight	2.0 - 2.3 kg (4.4 - 5.1 lbs.)

LXT BL MOTOR XPT



18V LXT Li-Ion Cordless 1.3 mm Metal Shear

DJS130

18V



Capacity	Steel up to 400 N/mm ² : 1.3 mm Steel up to 600 N/mm ² : 1.0 mm
No load speed	2,800 min ⁻¹
Dimensions (L x W x H)	350 x 80 x 193 mm (13-3/4 x 3-1/8 x 7-5/8")
Net weight	2.3 - 2.6 kg (5 - 5.8 lbs.)



18V LXT Li-Ion Cordless 1.6 mm Straight Shear

DJS161

18V



Capacity	Steel up to 400 N/mm ² : 1.6 mm Steel up to 600 N/mm ² : 1.2 mm Aluminum up to 200 N/mm ² : 2.5 mm
Strokes per minute	4,300 min ⁻¹
Dimensions (L x W x H)	362 x 78 x 118 mm (14-1/4 x 3-1/16 x 4-5/8")
Net weight	1.8 - 2.2 kg (4.1 - 4.8 lbs.)



18V LXT Li-Ion Cordless 1.0 mm Metal Shear

DJS101

18V



Capacity	Steel up to 400 N/mm ² : 1.0 mm Steel up to 600 N/mm ² : 0.7 mm Aluminum up to 200 N/mm ² : 2.5 mm
Strokes per minute	4,300 min ⁻¹
Dimensions (L x W x H)	364 x 78 x 118 mm (14-3/8 x 3-1/16 x 4-5/8")
Net weight	1.8 - 2.2 kg (4 - 4.7 lbs.)



18V LXT Li-Ion Cordless 1.6 mm (16 Ga) Nibbler

DJN161

18V



Capacity	Steel up to 400 N/mm ² : 1.6 mm Steel up to 600 N/mm ² : 1.2 mm Aluminum up to 200 N/mm ² : 2.5 mm
Min. cutting radius	Inside edge: 45 mm (1-3/4") Outside edge: 50 mm (2")
Strokes per minute	1,900 min ⁻¹
Dimensions (L x W x H)	313 x 78 x 189 mm (12-3/8 x 3-1/16 x 7-7/16")
Net weight	1.9 - 2.3 kg (4.3 - 5 lbs.)



18V LXT BL Cordless 13 mm (1/2") Cement Shear

DJS800

18V



Max cutting capacity	13 mm (1/2")
Strokes per minute	0 - 3,000 min ⁻¹
Dimensions (L x W x H)	w/ BL1830B / BL1840B / BL1850B / BL1860B: 379 x 79 x 216 mm (14-7/8 x 3-1/8 x 8-1/2")
Net weight	2.1 - 2.5 kg (4.6 - 5.5 lbs.)



8 mm (5/16") Cement Shear

JS8000



Continuous rating	570W
Input	
Capacity	Max cutting: 8 mm (5/16")
Strokes per minute	0 - 2,500 min ⁻¹
Dimensions (L x W x H)	346 x 70 x 223 mm (13-5/8 x 2-3/4 x 8-3/4")
Net weight	2.2 kg (4.8 lbs.)



1.6 mm (16 Ga) Straight Metal Shear

JS1601



Continuous rating	380W
Input	
Capacity	Steel up to 400 N/mm ² : 1.6 mm Steel up to 600 N/mm ² : 1.2 mm Steel up to 800 N/mm ² : 0.8 mm Aluminum up to 200 N/mm ² : 2.5 mm
Min. cutting radius	250 mm (9-7/8")
Strokes per minute	4,500 min ⁻¹
Dimensions (L x W x H)	320 x 70 x 78 mm (12-5/8 x 2-3/4 x 3-1/16")
Net weight	1.4 kg (3.2 lbs.)



1.0 mm (20 Ga) Metal Shear

JS1000



Continuous rating	380W
Input	
Capacity	Steel up to 400 N/mm ² : 1.0 mm Steel up to 600 N/mm ² : 0.7 mm Steel up to 800 N/mm ² : 0.5 mm Aluminum up to 200 N/mm ² : 2.5 mm
Min. cutting radius	30 mm (1-3/16")
Strokes per minute	4,500 min ⁻¹
Dimensions (L x W x H)	322 x 70 x 78 mm (12-5/8 x 2-3/4 x 3-1/16")
Net weight	1.4 kg (3.2 lbs.)



1.6 mm (16 Ga) Metal Shear

JS1602



Continuous rating	380W
Input	
Capacity	Steel up to 400 N/mm ² : 1.6 mm Steel up to 600 N/mm ² : 1.2 mm Steel up to 800 N/mm ² : 0.8 mm Aluminum up to 200 N/mm ² : 2.5 mm
Min. cutting radius	30 mm (1-3/16")
Strokes per minute	4,000 min ⁻¹
Dimensions (L x W x H)	255 x 74 x 146 mm (10 x 2-15/16 x 5-3/4")
Net weight	1.6 kg (3.4 lbs.)



3.2 mm (10 Ga) Metal Shear

JS3201



Continuous rating	710W
Input	
Capacity	Steel up to 400 N/mm ² : 3.2 mm Steel up to 600 N/mm ² : 2.5 mm Steel up to 800 N/mm ² : 1.5 mm Aluminum up to 200 N/mm ² : 4.0 mm
Min. cutting radius	50 mm (2")
Strokes per minute	1,600 min ⁻¹
Dimensions (L x W x H)	213 x 90 x 239 mm (8-3/8 x 3-1/2 x 9-3/8")
Net weight	3.4 kg (7.5 lbs.)



Cutting

1.6 mm (16 Ga) Nibbler

JN1601



Continuous rating Input	550W
Capacity	Steel up to 400 N/mm ² : 1.6 mm Steel up to 600 N/mm ² : 1.2 mm Steel up to 800 N/mm ² : 0.8 mm Aluminum up to 200 N/mm ² : 2.5 mm
Min. cutting radius	Outside edge: 50 mm (2") Inside edge: 45 mm (1-3/4")
Strokes per minute	2,200 min ⁻¹
Overall length	261 mm (10-1/4")
Net weight	1.6 kg (3.6 lbs.)



3.2 mm (10 Ga) Nibbler

JN3201



Continuous rating Input	710W
Capacity	Steel up to 400 N/mm ² : 3.2 mm Steel up to 600 N/mm ² : 2.5 mm Steel up to 800 N/mm ² : 1.0 mm Aluminum up to 200 N/mm ² : 3.5 mm
Min. cutting radius	Outside edge: 128 mm (5-1/16") Inside edge: 120 mm (4-3/4")
Strokes per minute	1,300 min ⁻¹
Dimensions (L x W x H)	225 x 90 x 254 mm (8-7/8 x 1-1/2 x 10")
Net weight	3.4 kg (7.4 lbs.)



18V LXT Cordless Cable Cutter

DTC104

18V

new



Max blade opening width	105 mm (4-1/8")
Max cable cutting capacity	Polyethylene power cable: ø72 mm (4 x 325 mm ²) PVC insulated multi-core cable: ø77 mm (3 x 325 mm ²) Annealed copper wire: ø105 mm (1,300 mm ²) Hard-drawn copper wire: ø90 mm (1,300 mm ²) Aluminum wire: ø105 mm (1,300 mm ²)
Dimensions (L x W x H)	718 x 123 x 267 mm (28-1/4 x 4-7/8 x 10-1/2")
Net weight	10.2 - 10.5 kg (22.5 - 23.1 lbs.)

LXT



18V LXT Li-Ion Cordless Cable Cutter

DTC100

18V



Max blade opening width	50 mm (2")
Max cable cutting capacity	600V-CV: 500mm ² single-core (ø38mm (1-1/2)) 6600V-CV: 500mm ² single-core (ø45mm (1-3/4)) 600V-IV: 500mm ² single-core (ø35mm (1-3/8)) 600V-VVR: 150mm ² triple-core (ø47mm (1-7/8))
Dimensions (L x W x H)	116 x 197 x 363 mm (4-9/16 x 7-3/4 x 14-1/4")
Net weight	2.9 kg (6.4 lbs.)

LXT



18V LXT Li-Ion Cordless Cable Cutter

DTC101

18V



Max blade opening width	50 mm (2")
Max cable cutting capacity	600V-CV: 500mm ² single-core (ø38mm (1-1/2)) 6600V-CV: 500mm ² single-core (ø45mm (1-3/4)) 600V-IV: 500mm ² single-core (ø35mm (1-3/8)) 600V-VVR: 150mm ² triple-core (ø47mm (1-7/8))
Dimensions (L x W x H)	116 x 190 x 430 mm (4-9/16 x 7-1/2 x 17")
Net weight	3.6 kg (7.9 lbs.)

LXT



18V LXT Li-Ion Cordless Cable Cutter

DTC102

18V



Max blade opening width	65 mm (2-9/16")
Max cable cutting capacity	Non-ferrous materials only (Al or Cu): 65 mm (2-9/16")
Dimensions (L x W x H)	116 x 228 x 400 mm (4-9/16 x 9 x 15-3/4")
Net weight	3.5 kg (7.7 lbs.)

LXT



18V LXT Li-Ion Cordless Cable Cutter, ACSR

DTC103

18V



Max blade opening width	54 mm (2-1/8")
Max cable cutting capacity	ACSR: Al 550mm ² / ST 70mm ²
Dimensions (L x W x H)	116 x 206 x 339 mm (4-9/16 x 8-1/8 x 13-3/8")
Net weight	5.5 kg (12.1 lbs.)

LXT



18V LXT Cordless Crimper

DTC301

18V

new



Output force	120 kN
Ram stroke length	31 mm (1-1/4")
Crimping capacity	Cu: ø19.5 mm (300 mm ²) Al: ø19.5 mm (300 mm ²)
Dimensions (L x W x H)	415 x 92 x 346 mm (16-3/8 x 3-5/8 x 13-5/8")
Net weight	6.8 - 7.1 kg (15.0 - 15.7 lbs.)

LXT



18V LXT Cordless Crimper

DTC302

18V

new



Output force	120 kN
Ram stroke length	42 mm (1-5/8")
Crimping capacity	Cu: ø22.5 mm (400 mm ²) Al: ø19.5 mm (300 mm ²)
Dimensions (L x W x H)	437 x 94 x 349 mm (17-1/4 x 3-11/16 x 13-3/4")
Net weight	7.5 - 7.8 kg (16.5 - 17.2 lbs.)

LXT



18V LXT Cordless Crimper

DTC303

18V

new



Output force	60 kN
Crimping capacity	Cu: ø17.5 mm (240 mm ²) Al: ø17.5 mm (240 mm ²)
Dimensions (L x W x H)	401 x 82 x 348 mm (15-3/4 x 3-1/4 x 13-3/4")
Net weight	5.3 - 5.7 kg (11.7 - 12.6 lbs.)

LXT



Cutting

40Vmax XGT BL AVT Cordless Toolless Multi Tool

TM001G

40V max



Oscillation angle	3.6°
Oscillations per minute	10,000-20,000 min ⁻¹
Circumference of grip portion	169 mm (6-5/8")
Dimensions (L x W x H)	326 x 91.5 x 123 mm (12-7/8 x 3-5/8 x 4-7/8")
Net weight	2.1 - 3.3 kg (4.6 - 7.3 lbs.)

XGT **BL** **AVT** **XPT**



18V LXT BL AVT Cordless Toolless Multi Tool

DTM52

18V



Oscillation angle	3.6°
Oscillations per minute	10,000-20,000 min ⁻¹
Circumference of grip portion	169 mm (6-5/8")
Dimensions (L x W x H)	322 x 95 x 126 mm (12-5/8 x 3-3/4 x 5")
Net weight	1.7 - 2.0 kg (3.7 - 4.4 lbs.)

LXT **BL** **AVT** **XPT**



18V LXT Brushless Cordless Tool-less Multi Tool

DTM53

18V

new



Oscillation angle	3.2°
Oscillations per minute	6,000 - 20,000 min ⁻¹
Circumference of grip portion	139 mm (5-1/2")
Dimensions (L x W x H)	329 x 80 x 120 mm (13 x 3-1/8 x 4-3/4")
Net weight	1.7 - 2.6 kg (3.7 - 5.7 lbs.)

LXT **BL** **XPT**



18V LXT Li-Ion Cordless Multi Tool

DTM50

18V



Oscillations per minute	6,000-20,000 min ⁻¹
Dimensions (L x W x H)	307 x 80 x 122 mm (12-1/4 x 3-1/8 x 4-13/16")
Net weight	1.8 - 2.2 kg (3.9 - 4.8 lbs.)

LXT



12V max CXT Li-Ion Cordless Multi Tool

TM30D

12V max



Oscillation angle	3.2°
Oscillations per minute	6,000 - 20,000 min ⁻¹
Circumference of grip portion	168 mm (6-5/8")
Dimensions (L x W x H)	277 x 65 x 98 mm (10-7/8 x 2-9/16 x 3-7/8")
Net weight	1.1 - 1.2 kg (2.4 - 2.6 lbs.)

CXT



320 W Toolless Multi Tool

TM3010C



Oscillation angle	3.2°
Continuous rating	320W
Input	
Strokes per minute	6,000 - 20,000 min ⁻¹
Dimensions (L x W x H)	283 x 68 x 87 mm (11-1/8 x 2-11/16 x 3-7/16")
Net weight	1.6 - 1.7 kg (3.7 - 3.9 lbs.)



320 W Multi Tool

TM3000C





















Oscillation angle	3.2°
Continuous rating	320W
Input	
Strokes per minute	6,000 - 20,000 min ⁻¹
Dimensions (L x W x H)	275 x 64 x 92 mm (10-7/8 x 2-1/2 x 3-5/8")
Net weight	1.4 - 1.5 kg (3.2 - 3.3 lbs.)



Sawing

Icon

 Double Insulation	 Variable Speed	 Brake	 Anti-restart function	 Mechanical 2-Speed
 Electronic 2-Speed	 Torque Limiter	 Constant Speed	 Soft Start	 Bevel Cutting 45 left
 Bevel Cutting 45 LR	 Bevel Cutting L45 R5	 Orbital Cutting	 Bayonet Shank Jig Saw Blade	 Laser Marker
 Dust Collection	 Toolless blade change	 Built-in Job Light	 Carrying Case	

40Vmax XGT BL AWS Cordless 305 mm (12") Slide Compound Miter Saw, LED Light

LS003G

40V max



Wheel diameter	305 mm (12")
No load speed	3,600 min ⁻¹
Bevel angle	Left: 48° / Right: 48°
Miter angle	Left: 60° / Right: 60°
Max cutting capacity	92 x 382 mm (3-5/8 x 15")
(Bevel 0° / Miter 0°)	107 x 363 mm (4-1/4 x 14-1/4")
Max cutting capacity	92 x 268 mm (3-5/8 x 10-1/2")
(Bevel 0° / Miter 45°LR)	107 x 255 mm (4-1/4 x 10")
Dimensions (L x W x H)	898 x 690 x 725 mm
	(35-1/4 x 27-1/4 x 28-1/2")
Net weight	30.5 - 31.7 kg (67.2 - 69.9 lbs.)

XGT BL DXT AWS



40Vmax XGT BL AWS Cordless 260 mm (10-1/4") Slide Compound Miter Saw, LED Light

LS004G

40V max



Wheel diameter	255 - 260 mm (10 - 10-1/4")
No load speed	3,600 min ⁻¹
Bevel angle	Left: 48° / Right: 48°
Miter angle	Left: 60° / Right: 60°
Max cutting capacity	68 x 310 mm (2-11/16 x 12-1/4")
(Bevel 0° / Miter 0°)	91 x 279 mm (3-5/8 x 11")
Max cutting capacity	68 x 218 mm (2-11/16 x 8-5/8")
(Bevel 0° / Miter 45°LR)	91 x 197 mm (3-5/8 x 7-3/4")
Dimensions (L x W x H)	805 x 644 x 660 mm
	(31-3/4 x 25-3/8 x 26")
Net weight	26.6 - 27.8 kg (58.6 - 61.3 lbs.)

XGT BL DXT AWS



40Vmax XGT BL AWS Cordless 216 mm (8-1/2") Slide Compound Miter Saw, LED Light

LS002G

40V max



Wheel diameter	216 mm (8-1/2")
No load speed	4,800 min ⁻¹
Bevel angle	Left: 48° / Right: 48°
Miter angle	Left: 60° / Right: 60°
Max cutting capacity	70 x 312 mm (2-3/4 x 12-1/4")
(Bevel 0° / Miter 0°)	
Max cutting capacity	70 x 220 mm (2-3/4 x 8-5/8")
(Bevel 0° / Miter 45°LR)	
Dimensions (L x W x H)	702 x 551 x 557 mm
	(27-5/8 x 21-3/4 x 22")
Net weight	16.4 - 17.0 kg (36.2 - 37.6 lbs.)

XGT BL DXT AWS



18V X2 (36V) LXT BL ADT Cordless 305 mm (12") Slide Compound Miter Saw, Laser

DLS212

18V x2



Wheel diameter	305 mm (12")
No load speed	4,400 min ⁻¹
Bevel angle	Left: 48° / Right: 48°
Miter angle	Left: 60° / Right: 60°
Max cutting capacity	92 x 382 mm (3-5/8 x 15")
(Bevel 0° / Miter 0°)	107 x 363 mm (4-1/4 x 14-1/4")
Max cutting capacity	92 x 268 mm (3-5/8 x 10-1/2")
(Bevel 0° / Miter 45°LR)	107 x 255 mm (4-1/4 x 10")
Dimensions (L x W x H)	898 x 690 x 725 mm
	(35-1/4 x 27-1/4 x 28-1/2")
Net weight	30.7 - 31.3 kg (67.6 - 69.1 lbs.)

LXT BL ADT DXT



18V X2 (36V) LXT BL AWS ADT Cordless 305 mm (12") Slide Compound Miter Saw, Laser

DLS211

18V x2



Wheel diameter	305 mm (12")
No load speed	4,400 min ⁻¹
Bevel angle	Left: 48° / Right: 48°
Miter angle	Left: 60° / Right: 60°
Max cutting capacity	92 x 382 mm (3-5/8 x 15")
(Bevel 0° / Miter 0°)	107 x 363 mm (4-1/4 x 14-1/4")
Max cutting capacity	92 x 268 mm (3-5/8 x 10-1/2")
(Bevel 0° / Miter 45°LR)	107 x 255 mm (4-1/4 x 10")
Dimensions (L x W x H)	898 x 690 x 725 mm
	(35-1/4 x 27-1/4 x 28-1/2")
Net weight	30.7 - 31.3 kg (67.6 - 69.1 lbs.)

LXT BL ADT DXT AWS



18V X2 (36V) LXT BL ADT Cordless 260 mm (10-1/4") Slide Compound Miter Saw, Laser

DLS112

18V x2



Wheel diameter	255 - 260 mm (10 - 10-1/4")
No load speed	4,400 min ⁻¹
Bevel angle	Left: 48° / Right: 48°
Miter angle	Left: 60° / Right: 60°
Max cutting capacity	68 x 310 mm (2-11/16 x 12-1/4")
(Bevel 0° / Miter 0°)	91 x 279 mm (3-5/8 x 11")
Max cutting capacity	68 x 218 mm (2-11/16 x 8-5/8")
(Bevel 0° / Miter 45°LR)	91 x 197 mm (3-5/8 x 7-3/4")
Dimensions (L x W x H)	805 x 644 x 660 mm
	(31-3/4 x 25-3/8 x 26")
Net weight	26.6 - 27.3 kg (58.6 - 60.2 lbs.)

LXT BL ADT DXT



18V X2 (36V) LXT BL AWS ADT Cordless 260 mm (10-1/4") Slide Compound Miter Saw, Laser

DLS111

18V x2



Wheel diameter	255 - 260 mm (10 - 10-1/4")
No load speed	4,400 min ⁻¹
Bevel angle	Left: 48° / Right: 48°
Miter angle	Left: 60° / Right: 60°
Max cutting capacity	68 x 310 mm (2-11/16 x 12-1/4")
(Bevel 0° / Miter 0°)	91 x 279 mm (3-5/8 x 11")
Max cutting capacity	68 x 218 mm (2-11/16 x 8-5/8")
(Bevel 0° / Miter 45°LR)	91 x 197 mm (3-5/8 x 7-3/4")
Dimensions (L x W x H)	805 x 644 x 660 mm
	(31-3/4 x 25-3/8 x 26")
Net weight	26.6 - 27.3 kg (58.6 - 60.2 lbs.)

LXT BL ADT DXT AWS



18V X2 (36V) LXT BL ADT Cordless 260 mm (10-1/4") Slide Compound Miter Saw, Laser

DLS110

18V x2



Wheel diameter	255 - 260 mm (10 - 10-1/4")
No load speed	4,400 min ⁻¹
Bevel angle	Left: 48° / Right: 48°
Miter angle	Left: 60° / Right: 60°
Max cutting capacity	68 x 310 mm (2-11/16 x 12-1/4")
(Bevel 0° / Miter 0°)	91 x 279 mm (3-5/8 x 11")
Max cutting capacity	68 x 218 mm (2-11/16 x 8-5/8")
(Bevel 0° / Miter 45°LR)	91 x 197 mm (3-5/8 x 7-3/4")
Dimensions (L x W x H)	805 x 644 x 660 mm
	(31-3/4 x 25-3/8 x 26")
Net weight	26.6 - 27.3 kg (58.6 - 60.2 lbs.)

LXT BL ADT DXT



18V X2 (36V) LXT BL ADT Cordless 190 mm (7-1/2") Dual Slide Compound Miter Saw

DLS714

18V x2



Wheel diameter	190 mm (7-1/2")
No load speed	5,700 min ⁻¹
Bevel angle	Left: 45° / Right: 5°
Miter angle	Left: 47° / Right: 57°
Max cutting capacity (Bevel 0° / Miter 0°)	52 x 300 mm (2-1/16 x 11-3/4")
Max cutting capacity (Bevel 0° / Miter 45°LR)	52 x 212 mm (2-1/16 x 8-3/8")
Dimensions (L x W x H)	655 x 430 x 445 mm (25-3/4 x 17 x 17-1/2")
Net weight	12.6 kg (27.8 lbs.)

LXT BL ADT



18V LXT Li-Ion Cordless 190 mm (7-1/2") Dual Slide Compound Miter Saw

DLS713

18V



Wheel diameter	190 mm (7-1/2")
No load speed	2,200 min ⁻¹
Bevel angle	Left: 45° / Right: 5°
Miter angle	Left: 47° / Right: 57°
Max cutting capacity (Bevel 0° / Miter 0°)	52 x 300 mm (2-1/16 x 11-3/4")
Max cutting capacity (Bevel 0° / Miter 45°LR)	52 x 212 mm (2-1/16 x 8-3/8")
Dimensions (L x W x H)	655 x 430 x 454 mm (25-3/4 x 17 x 17-7/8")
Net weight	12.1 kg (26.7 lbs.)

LXT

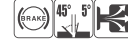

18V LXT BL ADT Cordless 165 mm (6-1/2") Compound Miter Saw with LED Light

DLS600

18V



Wheel diameter	155 - 165 mm (6-1/8 - 6-1/2")
No load speed	5,000 min ⁻¹
Bevel angle	Left: 46° / Right: 46°
Miter angle	Left: 52° / Right: 52°
Max cutting capacity (Bevel 0° / Miter 0°)	46 x 92 mm (1-13/16 x 3-5/8")
Max cutting capacity (Bevel 0° / Miter 45°LR)	46 x 65 mm (1-13/16 x 2-9/16")
Dimensions (L x W x H)	340 x 400 x 440 mm (13-3/8 x 15-3/4 x 17-1/4")
Net weight	6.3 - 6.6 kg (13.9 - 14.6 lbs.)

LXT BL ADT DXT



305 mm (12") 1,800 W Slide Compound Miter Saw, Laser

LS1219L



Continuous rating Input	1,800W
Wheel diameter	305 mm (12")
No load speed	3,200 min ⁻¹
Bevel angle	Left: 48° / Right: 48°
Miter angle	Left: 60° / Right: 60°
Max cutting capacity (Bevel 0° / Miter 0°)	92 x 382 mm (3-5/8 x 15")
Max cutting capacity (Bevel 0° / Miter 45°LR)	107 x 363 mm (4-1/4 x 14-1/4")
Max cutting capacity (Bevel 0° / Miter 45°LR)	92 x 268 mm (3-5/8 x 10-1/2")
Dimensions (L x W x H)	898 x 664 x 725 mm (35-1/4 x 26-1/8 x 28-1/2")
Net weight	29.5 kg (65 lbs.)

DXT



305 mm (12") 1,800 W Slide Compound Miter Saw

LS1219



Continuous rating Input	1,800W
Wheel diameter	305 mm (12")
No load speed	3,200 min ⁻¹
Bevel angle	Left: 48° / Right: 48°
Miter angle	Left: 60° / Right: 60°
Max cutting capacity (Bevel 0° / Miter 0°)	92 x 382 mm (3-5/8 x 15")
Max cutting capacity (Bevel 0° / Miter 45°LR)	107 x 363 mm (4-1/4 x 14-1/4")
Max cutting capacity (Bevel 0° / Miter 45°LR)	92 x 268 mm (3-5/8 x 10-1/2")
Dimensions (L x W x H)	898 x 664 x 725 mm (35-1/4 x 26-1/8 x 28-1/2")
Net weight	29.3 kg (64.6 lbs.)

DXT



260 mm (10-1/4") 1,510 W Slide Compound Miter Saw, Laser

LS1019L



Continuous rating Input	1,510W
Wheel diameter	255 - 260 mm (10 - 10-1/4")
No load speed	3,200 min ⁻¹
Bevel angle	Left: 48° / Right: 48°
Miter angle	Left: 60° / Right: 60°
Max cutting capacity (Bevel 0° / Miter 0°)	68 x 310 mm (2-11/16 x 12-1/4")
Max cutting capacity (Bevel 0° / Miter 45°LR)	91 x 279 mm (3-5/8 x 11")
Max cutting capacity (Bevel 0° / Miter 45°LR)	68 x 218 mm (2-11/16 x 8-5/8")
Dimensions (L x W x H)	805 x 644 x 660 mm (31-3/4 x 25-3/8 x 26")
Net weight	26.3 kg (57.9 lbs.)

DXT



260 mm (10-1/4") 1,510 W Slide Compound Miter Saw

LS1019



Continuous rating Input	1,510W
Wheel diameter	255 - 260 mm (10 - 10-1/4")
No load speed	3,200 min ⁻¹
Bevel angle	Left: 48° / Right: 48°
Miter angle	Left: 60° / Right: 60°
Max cutting capacity (Bevel 0° / Miter 0°)	68 x 310 mm (2-11/16 x 12-1/4")
Max cutting capacity (Bevel 0° / Miter 45°LR)	91 x 279 mm (3-5/8 x 11")
Max cutting capacity (Bevel 0° / Miter 45°LR)	68 x 218 mm (2-11/16 x 8-5/8")
Dimensions (L x W x H)	805 x 644 x 660 mm (31-3/4 x 25-3/8 x 26")
Net weight	26.1 kg (57.6 lbs.)

DXT



260 mm (10-1/4") 1,450 W Slide Compound Miter Saw, LED Light with Cut Line Guide Function

LS1110F



Continuous rating Input	1,450W
Wheel diameter	260 mm (10-1/4")
No load speed	4,500 min ⁻¹
Bevel angle	Left: 47° / Right: 2°
Miter angle	Left: 47° / Right: 47°
Max cutting capacity (Bevel 0° / Miter 0°)	91 x 310 mm (3-5/8 x 12-1/4")
Max cutting capacity (Bevel 0° / Miter 45°LR)	91 x 220 mm (3-5/8 x 8-5/8")
Dimensions (L x W x H)	745 x 497 x 565 mm (29-1/4 x 19-1/2 x 22-1/4")
Net weight	16.4 kg (36.2 lbs.)

DXT



260 mm (10-1/4") 1,430 W Slide Compound Miter Saw, Laser

LS1018L



Continuous rating Input	1,430W
Wheel diameter	255 - 260 mm (10 - 10-1/4")
Blade body thickness	1.5 - 3.2 mm
No load speed	4,300 min ⁻¹
Bevel angle	Left: 45° / Right: 45°
Miter angle	Left: 47° / Right: 60°
Max cutting capacity (Bevel 0° / Miter 0°)	91 x 310 mm (3-5/8 x 12-1/4")
Max cutting capacity (Bevel 0° / Miter 45°LR)	91 x 220 mm (3-5/8 x 8-5/8")
Dimensions (L x W x H)	825 x 536 x 633 mm (32-1/2 x 21-1/8 x 25")
Net weight	20.6 kg (45.4 lbs.)



260 mm (10-1/4") 1,430 W Slide Compound Miter Saw, Laser

LS1017L



Continuous rating Input	1,430W
Wheel diameter	255 - 260 mm (10 - 10-1/4")
Blade body thickness	1.5 - 3.2 mm
No load speed	4,200 min ⁻¹
Bevel angle	Left: 45° / Right: 5°
Miter angle	Left: 47° / Right: 60°
Max cutting capacity (Bevel 0° / Miter 0°)	91 x 310 mm (3-5/8 x 12-1/4")
Max cutting capacity (Bevel 0° / Miter 45°LR)	91 x 220 mm (3-5/8 x 8-5/8")
Dimensions (L x W x H)	825 x 536 x 581 mm (32-1/2 x 21-1/8 x 22-7/8")
Net weight	19.5 kg (43 lbs.)



Sawing

216 mm (8-1/2") 1,400 W Slide Compound Miter Saw, Laser, LED Light

LS0815FL



Continuous rating Input	1,400W
Wheel diameter	216 mm (8-1/2")
No load speed	5,000 min ⁻¹
Bevel angle	Left: 48° / Right: 5°
Miter angle	Left: 50° / Right: 60°
Max cutting capacity (Bevel 0° / Miter 0°)	65 x 305 mm (2-9/16 x 12")
Max cutting capacity (Bevel 0° / Miter 45°LR)	65 x 215 mm (2-9/16 x 8-1/2")
Dimensions (L x W x H)	755 x 450 x 488 mm (29-3/4 x 17-3/4 x 19-1/4")
Net weight	14.1 kg (31.1 lbs.)

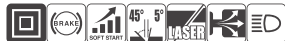

216 mm (8-1/2") 1,400 W Slide Compound Miter Saw, LED Light

LS0815F



Continuous rating Input	1,400W
Wheel diameter	216 mm (8-1/2")
No load speed	5,000 min ⁻¹
Bevel angle	Left: 48° / Right: 5°
Miter angle	Left: 50° / Right: 60°
Max cutting capacity (Bevel 0° / Miter 0°)	65 x 305 mm (2-9/16 x 12")
Max cutting capacity (Bevel 0° / Miter 45°LR)	65 x 215 mm (2-9/16 x 8-1/2")
Dimensions (L x W x H)	755 x 450 x 488 mm (29-3/4 x 17-3/4 x 19-1/4")
Net weight	14.1 kg (31.1 lbs.)



216 mm (8-1/2") 1,200 W Slide Compound Miter Saw, LED Light with Cut Line Guide Function

LS0816F



Continuous rating Input	1,200W
Wheel diameter	216 mm (8-1/2")
No load speed	5,000 min ⁻¹
Bevel angle	Left: 47° / Right: 2°
Miter angle	Left: 47° / Right: 47°
Max cutting capacity (Bevel 0° / Miter 0°)	65 x 305 mm (2-9/16 x 12")
Max cutting capacity (Bevel 0° / Miter 45°LR)	65 x 215 mm (2-9/16 x 8-1/2")
Dimensions (L x W x H)	705 x 476 x 521 mm (27-3/4 x 18-3/4 x 20-1/2")
Net weight	13.9 kg (30.6 lbs.)



190 mm (7-1/2") 1,010 W Slide Compound Miter Saw, Laser, Light

LS0714FL



Continuous rating Input	1,010W
Wheel diameter	190 mm (7-1/2")
Blade body thickness	1.3 - 2.0 mm
No load speed	6,000 min ⁻¹
Bevel angle	Left: 45° / Right: 5°
Miter angle	Left: 47° / Right: 57°
Max cutting capacity (Bevel 0° / Miter 0°)	52 x 300 mm (2-1/16 x 11-3/4")
Max cutting capacity (Bevel 0° / Miter 45°LR)	52 x 212 mm (2-1/16 x 8-3/8")
Dimensions (L x W x H)	670 x 430 x 458 mm (26-3/8 x 17 x 18")
Net weight	13.7 kg (30.2 lbs.)



190 mm (7-1/2") 1,010 W Slide Compound Miter Saw, Laser

LS0714L



Continuous rating Input	1,010W
Wheel diameter	190 mm (7-1/2")
Blade body thickness	1.3 - 2.0 mm
No load speed	6,000 min ⁻¹
Bevel angle	Left: 45° / Right: 5°
Miter angle	Left: 47° / Right: 57°
Max cutting capacity (Bevel 0° / Miter 0°)	52 x 300 mm (2-1/16 x 11-3/4")
Max cutting capacity (Bevel 0° / Miter 45°LR)	52 x 212 mm (2-1/16 x 8-3/8")
Dimensions (L x W x H)	670 x 430 x 458 mm (26-3/8 x 17 x 18")
Net weight	13.5 kg (29.8 lbs.)



190 mm (7-1/2") 1,010 W Slide Compound Miter Saw, Light

LS0714F



Continuous rating Input	1,010W
Wheel diameter	190 mm (7-1/2")
Blade body thickness	1.3 - 2.0 mm
No load speed	6,000 min ⁻¹
Bevel angle	Left: 45° / Right: 5°
Miter angle	Left: 47° / Right: 57°
Max cutting capacity (Bevel 0° / Miter 0°)	52 x 300 mm (2-1/16 x 11-3/4")
Max cutting capacity (Bevel 0° / Miter 45°LR)	52 x 212 mm (2-1/16 x 8-3/8")
Dimensions (L x W x H)	670 x 430 x 458 mm (26-3/8 x 17 x 18")
Net weight	13.4 kg (29.5 lbs.)



190 mm (7-1/2") 1,010 W Slide Compound Miter Saw

LS0714



Continuous rating Input	1,010W
Wheel diameter	190 mm (7-1/2")
Blade body thickness	1.3 - 2.0 mm
No load speed	6,000 min ⁻¹
Bevel angle	Left: 45° / Right: 5°
Miter angle	Left: 47° / Right: 57°
Max cutting capacity (Bevel 0° / Miter 0°)	52 x 300 mm (2-1/16 x 11-3/4")
Max cutting capacity (Bevel 0° / Miter 45°LR)	52 x 212 mm (2-1/16 x 8-3/8")
Dimensions (L x W x H)	670 x 430 x 458 mm (26-3/8 x 17 x 18")
Net weight	13.1 kg (28.9 lbs.)



305 mm (12") 1,650 W Compound Miter Saw

LS1221



Continuous rating Input	1,650W
Wheel diameter	305 mm (12")
No load speed	4,000 min ⁻¹
Bevel angle	Left: 45°
Miter angle	Left: 48° / Right: 48°
Max cutting capacity (Bevel 0° / Miter 0°)	98 x 153 mm (3-7/8 x 6")
Max cutting capacity (Bevel 0° / Miter 45°LR)	98 x 107 mm (3-7/8 x 4-1/4")
Dimensions (L x W x H)	674 x 610 x 607 mm (26-1/2 x 24 x 23-7/8")
Net weight	16.8 kg (37 lbs.)



260 mm (10-1/4") 1,650 W Compound Miter Saw with Light

LS1040F



Continuous rating Input	1,650W
Wheel diameter	260 mm (10-1/4")
No load speed	4,600 min ⁻¹
Bevel angle	Left: 45°
Miter angle	Left: 45° / Right: 52°
Max cutting capacity (Bevel 0° / Miter 0°)	93 x 95 mm (3-5/8 x 3-3/4")
Max cutting capacity (Bevel 0° / Miter 45°LR)	69 x 135 mm (2-3/4 x 5-5/16")
Dimensions (L x W x H)	530 x 476 x 532 mm (20-7/8 x 18-3/8 x 21")
Net weight	12.6 kg (27.8 lbs.)



260 mm (10-1/4") 1,650 W Compound Miter Saw

LS1040



Continuous rating Input	1,650W
Wheel diameter	255 - 260 mm (10/10-1/4")
No load speed	4,600 min ⁻¹
Bevel angle	Left: 45°
Miter angle	Left: 45° / Right: 52°
Max cutting capacity (Bevel 0° / Miter 0°)	93 x 95 mm (3-5/8 x 3-3/4")
Max cutting capacity (Bevel 0° / Miter 45°LR)	69 x 135 mm (2-3/4 x 5-5/16")
Dimensions (L x W x H)	530 x 476 x 532 mm (20-7/8 x 18-3/8 x 21")
Net weight	12.4 kg (27.3 lbs.)



260 mm (10-1/4") 1,650 W Compound Miter Saw

LS1045



Continuous rating Input	1,650W
Wheel diameter	255 - 260 mm (10/ 10-1/4")
No load speed	4,600 min ⁻¹
Bevel angle	Left: 45°
Miter angle	Left: 45° / Right: 52°
Max cutting capacity	93 x 95 mm (3-5/8 x 3-3/4")
(Bevel 0° / Miter 0°)	69 x 135 mm (2-3/4 x 5-5/16")
Max cutting capacity	93 x 67 mm (3-5/8 x 2-5/8")
(Bevel 0° / Miter 45°LR)	69 x 95 mm (2-3/4 x 3-3/4")
Dimensions (L x W x H)	530 x 476 x 532 mm (20-7/8 x 18-3/4 x 21")
Net weight	19 kg (41.9 lbs.)



355 mm (14") 1,380 W Miter Saw

LS1440



Continuous rating Input	1,380W
Wheel diameter	355 mm (14")
No load speed	3,200 min ⁻¹
Miter angle	Left: 45° / Right: 52°
Max cutting capacity	0°: 122 x 152 mm (4-13/16 x 6")
	45°: 122 x 115 mm (4-13/16 x 4-1/2")
Dimensions (L x W x H)	530 x 596 x 435 mm (20-7/8 x 23-1/2 x 17-1/8")
Net weight	34.2 kg (75.4 lbs.)



260 mm (10-1/4") 1,650 W Miter Saw

LS1030N



Continuous rating Input	1,650W
Wheel diameter	255 - 260 mm (10 - 10-1/4")
No load speed	4,600 min ⁻¹
Miter angle	Left: 45° / Right: 52°
Max cutting capacity	0°: 90.5 x 95 mm (3-9/16 x 3-3/4")
	45°: 90.5 x 67 mm (3-9/16 x 2-5/8")
Dimensions (L x W x H)	530 x 476 x 532 mm (20-7/8 x 18-3/4 x 21")
Net weight	12.1 kg (26.7 lbs.)



305 mm (12") 1,650W Table Top Miter Saw, Laser, LED Light

LH1201FL



Continuous rating Input	1,650W
Wheel diameter	305 mm (12")
No load speed	3,800 min ⁻¹
Bevel angle	Left: 45°
Miter angle	Left: 47° / Right: 52°
Max cutting capacity	62 x 200 mm (2-7/16 x 7-7/8")
(Bevel 0° / Miter 0°)	95 x 155 mm (3-3/4 x 6-1/8")
Max cutting capacity	62 x 135 mm (2-7/16 x 5-5/16")
(Bevel 0° / Miter 45°LR)	95 x 110 mm (3-3/4 x 4-5/16")
Dimensions (L x W x H)	610 x 535 x 692 mm (24 x 21 x 27-1/4")
Net weight	20.9 kg (46.1 lbs.)



260 mm (10-1/4") 1,650 W Table Top Miter Saw with LED Light

LH1040F



Continuous rating Input	1,650W
Wheel diameter	255/ 260 mm (10/ 10-1/4")
No load speed	4,800 min ⁻¹
Bevel angle	Left: 45°
Miter angle	Left: 45° / Right: 45°
Max cutting capacity	69 x 130 mm (2-3/4 x 5-1/8")
(Bevel 0° / Miter 0°)	93 x 95 mm (3-5/8 x 3-3/4")
Max cutting capacity	69 x 85 mm (2-3/4 x 3-3/8")
(Bevel 0° / Miter 45°LR)	93 x 67 mm (3-5/8 x 2-5/8")
Dimensions (L x W x H)	530 x 476 x 535 mm (20-7/8 x 18-3/4 x 21")
Net weight	14.3 kg (31.5 lbs.)



260 mm (10-1/4") 1,650 W Table Top Miter Saw

LH1040



Continuous rating Input	1,650W
Wheel diameter	255/ 260 mm (10/ 10-1/4")
No load speed	4,800 min ⁻¹
Bevel angle	Left: 45°
Miter angle	Left: 45° / Right: 45°
Max cutting capacity	69 x 130 mm (2-3/4 x 5-1/8")
(Bevel 0° / Miter 0°)	93 x 95 mm (3-5/8 x 3-3/4")
Max cutting capacity	69 x 85 mm (2-3/4 x 3-3/8")
(Bevel 0° / Miter 45°LR)	93 x 67 mm (3-5/8 x 2-5/8")
Dimensions (L x W x H)	530 x 476 x 535 mm (20-7/8 x 18-3/4 x 21")
Net weight	14.3 kg (31.5 lbs.)



260 mm (10-1/4") Flip Over Saw

LF1000



Continuous rating Input	1,650W
Wheel diameter	260 mm (10-1/4")
No load speed	2,700 min ⁻¹
Bevel angle	Left: 45°
Miter angle	Left: 45° / Right: 45°
Max cutting capacity	20 x 210 mm (13/16 x 8-1/4")
(Bevel 0° / Miter 0°)	68 x 155 mm (2-11/16 x 6-1/8")
Max cutting capacity	50 x 150 mm (2 x 5-7/8")
(Bevel 0° / Miter 45°LR)	
Dimensions (L x W x H)	Miter saw: 660 x 650 x 1,220 mm (26 x 25-1/2 x 48")
	Table saw: 660 x 650 x 1,060 mm (26 x 25-1/2 x 41-3/4")
Net weight	36 kg (79.4 lbs.)



315 mm (12-3/8") Table Saw

2712



Wheel diameter	315 mm (12-3/8")
No load speed	50 Hz: 2,950 min ⁻¹
	60 Hz: 3,400 min ⁻¹
Bevel capacity	0 - 45°
Max cutting capacity	0°: 85 mm (3-3/8")
	45°: 58 mm (2-1/4")
Dimensions (L x W x H)	1,670 x 700 x 810 mm (65-3/4 x 27-1/2 x 32")
Net weight	52.9 kg (116.6 lbs.)



260 mm (10-1/4") 1,650 W Table Saw

2704N



Continuous rating Input	1,650W
Wheel diameter	260 mm (10-1/4")
No load speed	5,200 min ⁻¹
Bevel capacity	-0.5 - 50°
Max cutting capacity	0°: 93 mm (3-5/8")
	45°: 64 mm (2-1/2")
Dimensions (L x W x H)	715 - 1,095 x 753 - 1,066 x 483 mm (28-1/8 - 43 x 29-5/8 - 42 x 19")
Net weight	35.2-37 kg (77.6-81.5 lbs.)



260 mm (10-1/4") 1,650 W Table Saw

2704



Continuous rating Input	1,650W
Wheel diameter	260 mm (10-1/4")
No load speed	4,800 min ⁻¹
Bevel capacity	-0.5 - 45.5°
Max cutting capacity	0°: 93 mm (3-5/8")
	45°: 64 mm (2-1/2")
Dimensions (L x W x H)	715 x 753 x 344 mm (28-1/8 x 29-5/8 x 13-1/2")
Net weight	34.9 kg (3 lbs.)



Sawing

260 mm (10-1/4") 1,500 W Table Saw

MLT100N

Continuous rating Input	1,500W
Wheel diameter	260 mm (10-1/4")
No load speed	4,300 min ⁻¹
Bevel capacity	0 - 45°
Max cutting capacity	0°: 93 mm (3-5/8") 45°: 64 mm (2-1/2")
Max cutting width	on the right side of blade: 630 mm (24-3/4")
Dimensions (L x W x H)	726 x 984 x 473 mm (28-1/2 x 38-3/4 x 18-5/8")
Net weight	34.8-35.1 kg (76.7-77.4 lbs.)



255 mm (10") 1,650 W Table Saw

2703

Continuous rating Input	1,650W
Wheel diameter	255 mm (10")
No load speed	4,600 min ⁻¹
Bevel range	0 - 45°
Max cutting capacity	0°: 91 mm (3-9/16") 45°: 63 mm (2-1/2")
Dimensions (L x W x H)	560 x 686 x 308 mm (22 x 27 x 12-1/8")
Net weight	17.8-18.9 kg (39.2-41.7 lbs.)



40Vmax XGT BL AWS Cordless 415 mm (16-5/16") Circular Saw, Electric Brake, Soft Start

HS013G

Wheel diameter	415 mm (16-5/16")
No load speed	2,100 min ⁻¹
Bevel range	0 - 45°
Max cutting capacity	0°: 160mm(6-5/16") 45°: 109 mm (4-1/4")
Dimensions (L x W x H)	606 x 233 x 476 mm (23-7/8 x 9-1/8 x 18-3/4")
Net weight	11.0 - 12.0 kg (24.3 - 26.5 lbs.)

40V max



XGT BL AWS XPT



40Vmax XGT BL AWS Cordless 255 mm (10") / 270 mm (10-5/8") Magnesium Circular Saw, Electric Brake, Soft Start, Twin LED Light

HS011G

Wheel diameter	255 - 270 mm (10 - 10-5/8")
No load speed	3,500 min ⁻¹
Bevel range	1 - 60°
Max cutting capacity	0°: 94 - 101 mm (3-11/16 - 4") 45°: 65 - 71 mm (2-9/16 - 2-13/16") 60°: 45 - 51 mm (1-3/4 - 2")
Dimensions (L x W x H)	w/ BL4080F: 453 x 214 x 336 mm (17-7/8 x 8-3/8 x 13-1/4")
Net weight	5.5 - 6.7 kg (12.1 - 14.8 lbs.)

40V max



XGT BL AWS XPT



40Vmax XGT BL AWS Cordless 235 mm (9-1/4") Circular Saw, Electric Brake, Soft Start, Twin LED Light

HS010G

Wheel diameter	235 mm (9-1/4")
No load speed	4,000 min ⁻¹
Bevel range	1 - 60°
Max cutting capacity	0°: 85 mm (3-3/8") 45°: 61 mm (2-3/8") 60°: 41 mm (1-5/8")
Dimensions (L x W x H)	430 x 224 x 316 mm (17 x 8-7/8 x 12-1/2")
Net weight	5.5 - 6.1 kg (12.1 - 13.4 lbs.)

40V max



XGT BL AWS XPT



40Vmax XGT BL AWS Cordless 235 mm (9-1/4") Magnesium Circular Saw, Electric Brake, Soft Start, Twin LED Light

HS009G

Wheel diameter	235 mm (9-1/4")
No load speed	4,000 min ⁻¹
Bevel range	1 - 60°
Max cutting capacity	0°: 85 mm (3-3/8") 45°: 61 mm (2-3/8") 60°: 51 mm (2")
Dimensions (L x W x H)	413 x 196 x 316 mm (16-1/4 x 7-3/4 x 12-1/2")
Net weight	5.1 - 5.7 kg (11.2 - 12.6 lbs.)

40V max



XGT BL AWS XPT



40Vmax XGT BL AWS ADT Cordless 190/185 mm (7-1/2" / 7-1/4") Magnesium Circular Saw, Electric Brake, Soft Start, Twin LED Light

HS003G

Wheel diameter	185 - 190 mm (7-1/4 - 7-1/2")
No load speed	6,000 min ⁻¹
Bevel range	0 - 56°
Max cutting capacity	0°: 66.0 - 68.5 mm (2-5/8 - 2-11/16") 45°: 45.5 - 47.5 mm (1-13/16 - 1-7/8") 56°: 34.0 - 35.5 mm (1-5/16 - 1-3/8")
Dimensions (L x W x H)	w/ BL4040: 331 x 200 x 290 mm (13 x 7-7/8 x 11-3/8")
Net weight	4.1 - 4.4 kg (9.0 - 9.7 lbs.)

40V max



XGT BL ADT AWS XPT



40Vmax XGT BL AWS ADT Cordless 190/185 mm (7-1/2" / 7-1/4") Magnesium Circular Saw, Electric Brake, Soft Start, Twin LED Light

HS004G

Wheel diameter	185 - 190 mm (7-1/4 - 7-1/2")
No load speed	6,000 min ⁻¹
Bevel range	0 - 48°
Max cutting capacity	0°: 60.0 - 62.5 mm (2-3/8 - 2-7/16") 45°: 43.0 - 44.5 mm (1-11/16 - 1-3/4") 48°: 41.0 - 42.0 mm (1-5/8 - 1-5/8")
Dimensions (L x W x H)	w/ BL4040: 337 x 210 x 290 mm (13-1/4 x 8-1/4 x 11-3/8")
Net weight	4.4 - 4.7 kg (9.7 - 10.4 lbs.)

40V max



XGT BL ADT AWS XPT



40Vmax XGT BL AWS Cordless 165 mm (6-1/2") Magnesium Circular Saw, Electric Brake, Soft Start, Twin LED Light

HS012G

Wheel diameter	165 mm (6-1/2")
No load speed	5,200 min ⁻¹
Bevel range	0 - 50°
Max cutting capacity	0°: 57 mm (2-1/4") 45°: 41 mm (1-5/8")
Dimensions (L x W x H)	352 x 157 x 246 mm (13-7/8 x 6-3/16 x 9-11/16")
Net weight	3.2 - 4.4 kg (7.1 - 9.7 lbs.)

40V max



XGT BL AWS XPT



18V X2 (36V) LXT BL AWS ADT Cordless 235 mm (9-1/4") Magnesium Circular Saw, Electric Brake, Soft Start, Twin LED Light

DHS900

Wheel diameter	235 mm (9-1/4")
No load speed	4,500 min ⁻¹
Bevel range	1 - 60°
Max cutting capacity	0°: 85 mm (3-3/8") 45°: 61 mm (2-3/8") 60°: 44 mm (1-3/4")
Dimensions (L x W x H)	413 x 196 x 316 mm (16-1/4 x 7-3/4 x 12-1/2")
Net weight	5.3 - 6.0 kg (11.7 - 13.2 lbs.)

18V x2



LXT BL ADT AWS XPT



18V X2 (36V) LXT BL AWS ADT Cordless 235 mm (9-1/4") Magnesium Circular Saw, Electric Brake, Soft Start, Twin LED Light

DHS901

18V x2



Wheel diameter	235 mm (9-1/4")
No load speed	4,500 min ⁻¹
Max cutting capacity	0°: 85 mm (3-3/8") 45°: 61 mm (2-3/8") 60°: 41 mm (1-5/8")
Dimensions (L x W x H)	430 x 224 x 316 mm (17 x 8-7/8 x 12-1/2")
Net weight	5.8 - 6.4 kg (12.8 - 14.1 lbs.)

LXT MOTOR BL ADT AWS XPT



18V X2 (36V) LXT BL AWS ADT Cordless 190/185 mm (7-1/2" / 7-1/4") Magnesium Circular Saw, Electric Brake, Soft Start, Dual LED Light

DHS783

18V x2



Wheel diameter	185/ 190 mm (7-1/4/ 7-1/2")
No load speed	6,000 min ⁻¹
Max cutting capacity	0°: 62.5 / 60 mm (2-7/16 / 2-3/8") 45°: 44.5 / 43 mm (1-3/4 / 1-11/16") 48°: 42 / 41 mm (1-5/8 / 1-5/8")
Dimensions (L x W x H)	348 x 210 x 290 mm (13-3/4 x 8-1/4 x 11-3/8")
Net weight	4.5 - 5.1 kg (9.9 - 11.3 lbs.)

LXT MOTOR BL ADT AWS XPT



18V X2 (36V) LXT BL ADT Cordless 190/185 mm (7-1/2" / 7-1/4") Magnesium Circular Saw, Electric Brake, Soft Start, Dual LED Light

DHS782

18V x2



Wheel diameter	185/ 190 mm (7-1/4/ 7-1/2")
No load speed	6,000 min ⁻¹
Max cutting capacity	0°: 62.5 / 60 mm (2-7/16 / 2-3/8") 45°: 44.5 / 43 mm (1-3/4 / 1-11/16") 48°: 42 / 41 mm (1-5/8 / 1-5/8")
Dimensions (L x W x H)	348 x 210 x 290 mm (13-3/4 x 8-1/4 x 11-3/8")
Net weight	4.5 - 5.1 kg (9.9 - 11.3 lbs.)

LXT MOTOR BL ADT XPT



18V X2 (36V) LXT BL AWS ADT Cordless 190/185 mm (7-1/2" / 7-1/4") Magnesium Circular Saw, Electric Brake, Soft Start, Dual LED Light

DHS781

18V x2



Wheel diameter	185/ 190 mm (7-1/4/ 7-1/2")
No load speed	6,000 min ⁻¹
Max cutting capacity	0°: 68.5 / 66 mm (2-11/16 / 2-5/8") 45°: 47.5 / 45.5 mm (1-7/8 / 1-13/16") 56°: 35.5 / 34 mm (1-3/8 / 1-5/16")
Dimensions (L x W x H)	342 x 200 x 290 mm (13-1/2 x 7-7/8 x 11-3/8")
Net weight	4.2 - 4.8 kg (9.3 - 10.7 lbs.)

LXT MOTOR BL ADT AWS XPT



18V X2 (36V) LXT BL ADT Cordless 190/185 mm (7-1/2" / 7-1/4") Magnesium Circular Saw, Electric Brake, Soft Start, Dual LED Light

DHS780

18V x2



Wheel diameter	185/ 190 mm (7-1/4/ 7-1/2")
No load speed	6,000 min ⁻¹
Max cutting capacity	0°: 68.5 / 66 mm (2-11/16 / 2-5/8") 45°: 47.5 / 45.5 mm (1-7/8 / 1-13/16") 56°: 35.5 / 34 mm (1-3/8 / 1-5/16")
Dimensions (L x W x H)	342 x 200 x 290 mm (13-1/2 x 7-7/8 x 11-3/8")
Net weight	4.2 - 4.8 kg (9.3 - 10.7 lbs.)

LXT MOTOR BL ADT XPT



18V X2 (36V) LXT Li-Ion Cordless 190 / 185 mm (7-1/2" / 7-1/4") Circular Saw, Electric Brake, Soft Start

DHS710

18V x2



Wheel diameter	185/ 190 mm (7-1/4/ 7-1/2")
No load speed	4,800 min ⁻¹
Max cutting capacity	0°: 68.5 / 66 mm (2-11/16 / 2-5/8") 45°: 49 / 47.5 mm (1-15/16 / 1-7/8") 50°: 44 / 42.5 mm (1-3/4 / 1-11/16")
Dimensions (L x W x H)	356 x 217 x 298 mm (14 x 8-1/2 x 11-3/4")
Net weight	3.9 - 4.6 kg (8.6 - 10.1 lbs.)

LXT



18V LXT BL AWS ADT Cordless 165 mm (6-1/2") Circular Saw, Electric Brake, Soft Start, Dual LED Lights

DHS661

18V



Wheel diameter	165 mm (6-1/2")
No load speed	5,000 min ⁻¹
Max cutting capacity	0°: 57 mm (2-1/4") 45°: 41 mm (1-5/8") 50°: 37 mm (1-7/16")
Dimensions (L x W x H)	270 x 186 x 250 mm (10-5/8 x 7-3/8 x 9-7/8")
Net weight	2.9 - 3.2 kg (6.4 - 7.1 lbs.)

LXT MOTOR BL ADT AWS XPT



18V LXT BL ADT Cordless 165 mm (6-1/2") Circular Saw, Electric Brake, Soft Start, Dual LED Lights

DHS660

18V



Wheel diameter	165 mm (6-1/2")
No load speed	5,000 min ⁻¹
Max cutting capacity	0°: 57 mm (2-1/4") 45°: 41 mm (1-5/8") 50°: 37 mm (1-7/16")
Dimensions (L x W x H)	270 x 186 x 250 mm (10-5/8 x 7-3/8 x 9-7/8")
Net weight	2.9 - 3.2 kg (6.3 - 7.0 lbs.)

LXT MOTOR BL ADT XPT



18V LXT BL ADT Cordless 165 mm (6-1/2") Circular Saw, Electric Brake, Soft Start, Dual LED Lights

DHS680

18V



Wheel diameter	165 mm (6-1/2")
No load speed	5,000 min ⁻¹
Bevel range	0 - 50°
Max cutting capacity	0°: 57 mm (2-1/4") 45°: 41 mm (1-5/8") 50°: 37 mm (1-7/16")
Dimensions (L x W x H)	350 x 170 x 238 mm (13-3/4 x 6-11/16 x 9-3/8")
Net weight	3.0 - 3.3 kg (6.6 - 7.3 lbs.)

LXT MOTOR BL ADT



18V LXT Li-Ion Cordless 165 mm (6-1/2") Circular Saw, Electric Brake, Dual LED Light

DHS630

18V



Wheel diameter	165 mm (6-1/2")
No load speed	3,100 min ⁻¹
Max cutting capacity	0°: 66 mm (2-5/8") 45°: 46 mm (1-13/16")
Dimensions (L x W x H)	346 x 220 x 247 mm (13-5/8 x 8-5/8 x 9-3/4")
Net weight	3 - 3.4 kg (6.6 - 7.5 lbs.)

LXT



Sawing

18V LXT Li-Ion Cordless 165 mm (6-1/2") Circular Saw, Electric Brake, LED Light

DSS610

18V



Wheel diameter	165 mm (6-1/2")
No load speed	3,700 min ⁻¹
Max cutting capacity	0°: 0 - 57 mm (0 - 2-1/4") 45°: 0 - 40 mm (0 - 1-9/16") 50°: 0 - 36 mm (0 - 1-7/16")
Dimensions (L x W x H)	347 x 202 x 228 mm (13-5/8 x 8 x 9")
Net weight	3 - 3.4 kg (6.7 - 7.5 lbs.)

LXT



18V LXT Li-Ion Cordless 165 mm (6-1/2") Circular Saw

DSS611

18V



Wheel diameter	165 mm (6-1/2")
No load speed	3,700 min ⁻¹
Max cutting capacity	0°: 57 mm (2-1/4") 45°: 40 mm (1-9/16") 50°: 36 mm (1-7/16")
Dimensions (L x W x H)	347 x 202 x 228 mm (13-5/8 x 8 x 9")
Net weight	2.9 - 3.2 kg (6.4 - 7.1 lbs.)

LXT



18V LXT Li-Ion Cordless 136 mm (5-3/8") Circular Saw, Electric Brake, Dual LED Lights

DSS501

18V



Wheel diameter	136 mm (5-3/8")
No load speed	3,600 min ⁻¹
Max cutting capacity	0°: 51 mm (2") 45°: 35 mm (1-3/8")
Dimensions (L x W x H)	364 x 183 x 201 mm (14-3/8 x 7-1/4 x 7-7/8")
Net weight	2.4 - 2.7 kg (5.3 - 6.0 lbs.)

LXT



12V max CXT Li-Ion Cordless 85 mm (3-3/8") Circular Saw

HS301D

12V max



Wheel diameter	85 mm (3-3/8")
No load speed	1,500 min ⁻¹
Max cutting capacity	0°: 25.5 mm (1") 45°: 16.5 mm (5/8")
Dimensions (L x W x H)	313 x 170 x 155 mm (12-3/8 x 6-11/16 x 6-1/8")
Net weight	1.6 - 1.7 kg (3.5 - 3.8 lbs.)

CXT



10.8V (12V max) Li-Ion Cordless 85 mm (3-3/8") Circular Saw

HS300D

10.8V



Wheel diameter	85 mm (3-3/8")
No load speed	1,400 min ⁻¹
Max cutting capacity	0°: 25.5 mm (1") 45°: 16.5 mm (5/8")
Dimensions (L x W x H)	300 x 170 x 154 mm (11-3/4 x 6-11/16 x 6-1/16")
Net weight	1.5 kg (3.3 lbs.)



415 mm (16-5/16") 1,650 W Circular Saw, Electric Brake

5402NA



Continuous rating Input	1,650W
Wheel diameter	415 mm (16-5/16")
No load speed	2,200 min ⁻¹
Max cutting capacity	0°: 158 mm (6-1/4") 45°: 106 mm (4-3/16")
Overall length	616 mm (24-1/4")
Net weight	12.5 kg (27.6 lbs.)



415 mm (16-5/16") Circular Saw

5402



Continuous rating Input	1,450W
Wheel diameter	415 mm (16-5/16")
No load speed	2,200 min ⁻¹
Max cutting capacity	0°: 157 mm (6-3/16") 45°: 106 mm (4-3/16")
Overall length	615 mm (24-1/4")
Net weight	12.9 kg (28.4 lbs.)

355 mm (14") 2,200 W SJS Circular Saw, Electric Brake, Soft Start

5143R



Continuous rating Input	2,200W
Wheel diameter	355 mm (14")
No load speed	2,700 min ⁻¹
Max cutting capacity	0°: 130 mm (5-1/8") 45°: 90 mm (3-1/2")
Overall length	607 mm (23-7/8")
Net weight	12.5 kg (27.6 lbs.)

SUPER JOINT SYSTEM
SJS

335 mm (13-1/8") 1,750 W Circular Saw

5103N



Continuous rating Input	1,750W
Wheel diameter	335 mm (13-1/8")
No load speed	2,900 min ⁻¹
Max cutting capacity	0°: 128 mm (5") 45°: 91 mm (3-5/8")
Overall length	505 mm (19-7/8")
Net weight	8.9 kg (19.6 lbs.)

270 mm (10-5/8") 2,100 W SJS Circular Saw, Electric Brake, Soft Start

5103R



Continuous rating Input	2,100W
Wheel diameter	270 mm (10-5/8")
No load speed	3,800 min ⁻¹
Max cutting capacity	0°: 100 mm (3-15/16") 45°: 73 mm (2-7/8")
Overall length	442 mm (17-3/8")
Net weight	9.3 kg (20.6 lbs.)

SUPER JOINT SYSTEM
SJS

235 mm (10") / 270 mm (10-5/8") 2,000 W Circular Saw

HS0600



Continuous rating Input	2,000W
Wheel diameter	235 - 270 mm (10 - 10-5/8")
No load speed	4,300 min ⁻¹
Max cutting capacity	0°: 97/ 101 mm (3-13/16/ 4") 45°: 68/ 71 mm (2-11/16/ 2-13/16") 50°: 61/ 63 mm (2-3/8/ 2-1/2")
Dimensions (L x W x H)	418 x 273 x 324 mm (16-1/2 x 10-3/4 x 12-3/4")
Net weight	6.9 kg (15.2 lbs.)



260 mm (10-1/4") / 270 mm (10-5/8") 2,100 W SJS Circular Saw, Electric Brake

5104



Continuous rating Input	1,700W
Wheel diameter	260 - 270 mm (10-1/4 - 10-5/8")
No load speed	3,800 min ⁻¹
Max cutting capacity	0°: 95/ 100 mm (3-3/4/ 3-15/16") 45°: 69/ 73 mm (2-3/4/ 2-7/8")
Dimensions (L x W x H)	405 x 315 x 323 mm (16 x 12-3/8 x 12-3/4")
Net weight	8.2 kg (18.2 lbs.)



235 mm (9-1/4") 2,000 W Circular Saw, Electric Brake, Soft Start

5903R



Continuous rating Input	2,000W
Wheel diameter	235 mm (9-1/4")
No load speed	4,500 min ⁻¹
Max cutting capacity	0°: 85 mm (3-11/32") 45°: 64 mm (2-1/2")
Overall length	400 mm (15-3/4")
Net weight	7.2 kg (15.9 lbs.)



235 mm (9-1/4") 2,000 W Circular Saw

5902B



Continuous rating Input	2,000W
Wheel diameter	235 mm (9-1/4")
No load speed	4,100 min ⁻¹
Max cutting capacity	0°: 85 mm (3-3/8") 45°: 60 mm (2-3/8") 50°: 53 mm (2-1/16")
Overall length	380 mm (15")
Net weight	6.9 kg (15.1 lbs.)



235 mm (9-1/4") 2,000 W Circular Saw

N5900B



Continuous rating Input	2,000W
Wheel diameter	235 mm (9-1/4")
No load speed	4,100 min ⁻¹
Max cutting capacity	0°: 85 mm (3-3/8") 45°: 60 mm (2-3/8") 50°: 53 mm (2-1/16")
Overall length	380 mm (15")
Net weight	6.8 kg (14.8 lbs.)



210 mm (8-1/4") 1,800 W Magnesium Circular Saw, Electric Brake, Dual LED Lights

5008MGA



Continuous rating Input	1,800W
Wheel diameter	210 mm (8-1/4")
No load speed	5,200 min ⁻¹
Max cutting capacity	0°: 75.5 mm (3") 45°: 57 mm (2-1/4") 50°: 51.5 mm (2")
Dimensions (L x W x H)	332 x 243 x 277 mm (13-1/8 x 9-9/16 x 10-7/8")
Net weight	4.8 kg (10.6 lbs.)



210 mm (8-1/4") 1,800 W Magnesium Circular Saw with Dual LED Lights

5008MG



Continuous rating Input	1,800W
Wheel diameter	210 mm (8-1/4")
No load speed	5,200 min ⁻¹
Max cutting capacity	0°: 75.5 mm (3") 45°: 57 mm (2-1/4") 50°: 51.5 mm (2")
Dimensions (L x W x H)	332 x 243 x 277 mm (13-1/8 x 9-9/16 x 10-7/8")
Net weight	4.8 kg (10.6 lbs.)



190 mm (7-1/2") 1,400 W Circular Saw, Electric Brake, Dual LED Lights

HS7101



Continuous rating Input	1,400W
Wheel diameter	190 mm (7-1/2")
No load speed	5,500 min ⁻¹
Max cutting capacity	0°: 67 mm (2-5/8") 45°: 48.5 mm (1-15/16") 50°: 43.5 mm (1-11/16")
Dimensions (L x W x H)	310 x 246 x 258 mm (12-1/4 x 9-11/16 x 10-1/8")
Net weight	3.8 kg (8.4 lbs.)



190 mm (7-1/2") 1,400 W Circular Saw

HS7100



Continuous rating Input	1,400W
Wheel diameter	190 mm (7-1/2")
No load speed	5,500 min ⁻¹
Max cutting capacity	0°: 67 mm (2-5/8") 45°: 48.5 mm (1-15/16") 50°: 43.5 mm (1-11/16")
Dimensions (L x W x H)	310 x 246 x 258 mm (12-1/4 x 9-11/16 x 10-1/8")
Net weight	3.7 kg (8.2 lbs.)



190 mm (7-1/2") 1,200 W Circular Saw

HS7601



Continuous rating Input	1,200W
Wheel diameter	190 mm (7-1/2")
No load speed	5,200 min ⁻¹
Max cutting capacity	0°: 66 mm (2-5/8") 45°: 46 mm (1-13/16")
Dimensions (L x W x H)	309 x 232 x 255 mm (12-1/8 x 9-1/8 x 10")
Net weight	3.8 kg (8.4 lbs.)



Sawing

185 mm (7-1/4") 1,800 W Magnesium Circular Saw, Electric Brake, Dual LED Lights

5007MGA

Continuous rating	1,800W
Input	
Wheel diameter	185 mm (7-1/4")
No load speed	5,800 min ⁻¹
Max cutting capacity	0°: 63.5 mm (2-1/2") 45°: 45 mm (1-3/4") 56°: 35 mm (1-3/8")
Dimensions (L x W x H)	317 x 240 x 265 mm (12-1/2 x 9-1/2 x 10-3/8")
Net weight	4.6 kg (10.1 lbs.)



185 mm (7-1/4") 1,800 W Magnesium Circular Saw with Dual LED Lights

5007MG

Continuous rating	1,800W
Input	
Wheel diameter	185 mm (7-1/4")
No load speed	5,800 min ⁻¹
Max cutting capacity	0°: 63.5 mm (2-1/2") 45°: 45 mm (1-3/4") 56°: 35 mm (1-3/8")
Dimensions (L x W x H)	317 x 240 x 265 mm (12-1/2 x 9-1/2 x 10-3/8")
Net weight	4.6 kg (10.1 lbs.)



185 mm (7-1/4") 1,800 W Circular Saw with Dual LED Lights

5007NF

Continuous rating	1,800W
Input	
Wheel diameter	185 mm (7-1/4")
No load speed	5,800 min ⁻¹
Max cutting capacity	0°: 63.5 mm (2-1/2") 45°: 45 mm (1-3/4") 50°: 35 mm (1-3/8")
Dimensions (L x W x H)	317 x 240 x 265 mm (12-1/2 x 9-1/2 x 10-3/8")
Net weight	5 kg (11 lbs.)



185 mm (7-1/4") 1,800 W Circular Saw

5007N

Continuous rating	1,800W
Input	
Wheel diameter	185 mm (7-1/4")
No load speed	5,800 min ⁻¹
Max cutting capacity	0°: 63.5 mm (2-1/2") 45°: 45 mm (1-3/4") 50°: 35 mm (1-3/8")
Dimensions (L x W x H)	317 x 240 x 265 mm (12-1/2 x 9-1/2 x 10-3/8")
Net weight	5 kg (11 lbs.)



185 mm (7-1/4") / 190 mm (7-1/2") 1,600 W Circular Saw

HS7611

Continuous rating	1,600W
Input	
Wheel diameter	185/190 mm (7-1/4/7-1/2")
No load speed	5,500 min ⁻¹
Max cutting capacity	0°: 63/65 mm (2-1/2/2-9/16") 45°: 44/45 mm (1-3/4/1-3/4")
Dimensions (L x W x H)	311 x 240 x 261 mm (12-1/4 x 9-1/2 x 10-1/4")
Net weight	3.9 kg (8.7 lbs.)



185 mm (7-1/4") / 190 mm (7-1/2") 1,600 W Circular Saw

HS7610

Continuous rating	1,600W
Input	
Wheel diameter	185/190 mm (7-1/4/7-1/2")
No load speed	5,500 min ⁻¹
Max cutting capacity	0°: 63/65 mm (2-1/2/2-9/16") 45°: 44/45 mm (1-3/4/1-3/4")
Dimensions (L x W x H)	311 x 242 x 261 mm (12-1/4 x 9-1/2 x 10-1/4")
Net weight	3.9 kg (8.7 lbs.)



185 mm (7-1/4") / 190 mm (7-1/2") 1,600 W Circular Saw

HS7010

Continuous rating	1,600W
Input	
Wheel diameter	185 - 190 mm (7-1/4 - 7-1/2")
No load speed	5,500 min ⁻¹
Max cutting capacity	0°: 65/67 mm (2-9/16/2-5/8") 45°: 44/45 mm (1-3/4/1-3/4")
Dimensions (L x W x H)	300 x 240 x 261 mm (11-3/4 x 9-1/2 x 10-1/4")
Net weight	4 kg (8.9 lbs.)



185 mm (7-1/4") 1,400 W Circular Saw

5007NB

Continuous rating	1,400W
Input	
Wheel diameter	185 mm (7-1/4")
No load speed	5,800 min ⁻¹
Max cutting capacity	0°: 60 mm (2-3/8") 45°: 46 mm (1-3/4")
Overall length	295 mm (11-5/8")
Net weight	4.8 kg (10.5 lbs.)



185 mm (7-1/4") 1,200 W Circular Saw

HS7000

Continuous rating	1,200W
Input	
Wheel diameter	185 mm (7-1/4")
No load speed	5,200 min ⁻¹
Max cutting capacity	0°: 65 mm (2-9/16") 45°: 43 mm (1-11/16")
Dimensions (L x W x H)	298 x 230 x 255 mm (11-11/16 x 9-1/16 x 10")
Net weight	3.8 kg (8.4 lbs.)



185 mm (7-1/4") 1,200 W Circular Saw

HS7600

Continuous rating	1,200W
Input	
Wheel diameter	185 mm (7-1/4")
No load speed	5,200 min ⁻¹
Max cutting capacity	0°: 64 mm (2-1/2") 45°: 42 mm (1-5/8")
Dimensions (L x W x H)	309 x 234 x 255 mm (12-1/8 x 9-1/4 x 10")
Net weight	3.8 kg (8.3 lbs.)



185 mm (7-1/4") 1,050 W Circular Saw

5806B



Continuous rating	1,050W
Input	
Wheel diameter	185 mm (7-1/4")
No load speed	5,200 min ⁻¹
Max cutting capacity	0°: 66 mm (2-5/8") 45°: 44 mm (1-11/16")
Overall length	282 mm (11-1/8")
Net weight	3.5 kg (7.6 lbs.)



180 mm (7-1/8") 900 W Circular Saw

5800NB



Continuous rating	900W
Input	
Wheel diameter	180 mm (7-1/8")
No load speed	4,500 min ⁻¹
Max cutting capacity	0°: 64 mm (2-1/2") 45°: 43 mm (1-11/16")
Overall length	272 mm (10-3/4")
Net weight	3.5 kg (7.7 lbs.)



165 mm (6-1/2") 1,100 W Circular Saw, Electric Brake, Dual LED Lights

HS6101



Continuous rating	1,100W
Input	
Wheel diameter	165 mm (6-1/2")
No load speed	5,500 min ⁻¹
Max cutting capacity	0°: 54.5 mm (2-1/8") 45°: 39.5 mm (1-9/16") 50°: 35.5 mm (1-3/8")
Dimensions (L x W x H)	297 x 246 x 246 mm (11-3/4 x 9-11/16 x 9-11/16")
Net weight	3.5 kg (7.7 lbs.)



165 mm (6-1/2") 1,100 W Circular Saw

HS6100



Continuous rating	1,100W
Input	
Wheel diameter	165 mm (6-1/2")
No load speed	5,500 min ⁻¹
Max cutting capacity	0°: 54.5 mm (2-1/8") 45°: 39.5 mm (1-9/16") 50°: 35.5 mm (1-3/8")
Dimensions (L x W x H)	297 x 246 x 246 mm (11-3/4 x 9-11/16 x 9-11/16")
Net weight	3.5 kg (7.7 lbs.)



165 mm (6-1/2") 1,050 W Circular Saw

HS6601



Continuous rating	1,050W
Input	
Wheel diameter	165 mm (6-1/2")
No load speed	5,200 min ⁻¹
Max cutting capacity	0°: 54.5 mm (2-1/8") 45°: 37.5 mm (1-1/2")
Dimensions (L x W x H)	296 x 232 x 243 mm (11-5/8 x 9-1/8 x 9-9/16")
Net weight	3.4 kg (7.6 lbs.)



165 mm (6-1/2") 1,050 W Circular Saw

HS6600



Continuous rating	1,050W
Input	
Wheel diameter	165 mm (6-1/2")
No load speed	5,200 min ⁻¹
Max cutting capacity	0°: 54.5 mm (2-1/8") 45°: 37.5 mm (1-1/2")
Dimensions (L x W x H)	296 x 230 x 243 mm (11-5/8 x 9 x 9-9/16")
Net weight	3.5 kg (7.6 lbs.)



185 mm (7-1/4") 1,400 W Circular Saw with Dust Collection

5057KB



Continuous rating	1,400W
Input	
Wheel diameter	185 mm (7-1/4")
No load speed	5,800 min ⁻¹
Max cutting capacity	0°: 60 mm (2-3/8") 45°: 30 mm (1-1/8")
Overall length	354 mm (14")
Net weight	5.1 kg (11.2 lbs.)



40Vmax XGT BL AWS Cordless 260 mm (10-1/4") Magnesium Rear Handle Saw, Electric Brake, Soft Start

RS002G

40V max



Wheel diameter	260 mm (10-1/4")
No load speed	4,000 min ⁻¹
Max cutting capacity	0°: 95 mm (3-3/4") 45°: 70 mm (2-3/4") 56°: 54.5 mm (2-1/8")
Dimensions (L x W x H)	489 x 193 x 309 mm (19-1/4 x 7-5/8 x 12-1/8")
Net weight	5.7 - 6.3 kg (12.6 - 13.9 lbs.)

XGT BL AWS XPT



40Vmax XGT BL ADT Cordless 185 mm (7-1/4") Magnesium Rear Handle Saw, Electric Brake, Soft Start

RS001G

40V max



Wheel diameter	185 mm (7-1/4")
No load speed	6,400 min ⁻¹
Max cutting capacity	0°: 65 mm (2-9/16") 45°: 45 mm (1-3/4") 53°: 38 mm (1-1/2")
Dimensions (L x W x H)	446 x 196 x 270 mm (17-1/2 x 7-3/4 x 10-5/8")
Net weight	5.0 - 5.6 kg (11.0 - 12.3 lbs.)

XGT BL ADT XPT



18V X2 (36V) LXT BL ADT Cordless 185 mm (7-1/4") Magnesium Rear Handle Saw, Electric Brake, Soft Start

DRS780

18V x2



Wheel diameter	185 mm (7-1/4")
No load speed	5,100 min ⁻¹
Max cutting capacity	0°: 65 mm (2-9/16") 45°: 45 mm (1-3/4") 53°: 38 mm (1-1/2")
Dimensions (L x W x H)	446 x 196 x 270 mm (17-1/2 x 7-3/4 x 10-5/8")
Net weight	5 - 5.6 kg (11.1 - 12.4 lbs.)

LXT BL ADT XPT



Sawing

185 mm (7-1/4") Magnesium Hypoid Saw

5377MG

Wheel diameter	185 mm (7-1/4")
No load speed	4,500 min ⁻¹
Max cutting capacity	0°: 60 mm (2-3/8") 45°: 44 mm (1-3/4") 50°: 40 mm (1-9/16")
Dimensions (L x W x H)	450 x 183 x 254 mm (17-3/4 x 7-1/4 x 10")
Net weight	6 kg (13.1 lbs.)



185 mm (7-1/4") Hypoid Saw

5477NB

Continuous rating Input	1,800W
Wheel diameter	185 mm (7-1/4")
No load speed	4,500 min ⁻¹
Max cutting capacity	0°: 60 mm (2-3/8") 45°: 44 mm (1-3/4") 50°: 40 mm (1-9/16")
Dimensions (L x W x H)	442 x 183 x 254 mm (17-3/8 x 7-1/4 x 10")
Net weight	6.3 kg (13.9 lbs.)



40Vmax XGT BL Cordless 165 mm (6-1/2") Plunge Cut Saw

SP001G

40V max

Wheel diameter	165 mm (6-1/2")
No load speed	2,500 - 4,900 min ⁻¹
Bevel range	1 - 48°
Max cutting capacity	0°: 56 mm (2-3/16") 45°: 40 mm (1-9/16") 48°: 38 mm (1-1/2")
Dimensions (L x W x H)	w/ BL4050F: 394 x 221 x 271 mm (15-1/2 x 8-3/4 x 10-5/8")
Net weight	4.4 - 5.6 kg (9.7 - 12.3 lbs.)



XGT BL MOTOR AWS XPT



18V X2 (36V) LXT BL Cordless 165 mm (6-1/2") Plunge Cut Saw

DSP601

18V x2

Wheel diameter	165 mm (6-1/2")
No load speed	2,500 - 6,300 min ⁻¹
Bevel range	1 - 48°
Max cutting capacity	0°: 56 mm (2-3/16") 45°: 40 mm (1-9/16") 48°: 38 mm (1-1/2")
Dimensions (L x W x H)	346 x 241 x 272 mm (13-5/8 x 9-1/2 x 10-3/4")
Net weight	4.4 - 5.1 kg (9.8 - 11.2 lbs.)



LXT BL MOTOR ADT AWS



18V X2 (36V) LXT BL Cordless 165 mm (6-1/2") Plunge Cut Saw

DSP600

18V x2

Wheel diameter	165 mm (6-1/2")
No load speed	2,500 - 6,300 min ⁻¹
Bevel capacity	-1 - 48°
Max cutting capacity	0°: 56 mm (2-3/16") 45°: 40 mm (1-9/16") 48°: 38 mm (1-1/2")
Dimensions (L x W x H)	346 x 241 x 272 mm (13-5/8 x 9-1/2 x 10-3/4")
Net weight	4.4 - 5.1 kg (9.8 - 11.2 lbs.)



LXT BL MOTOR ADT



165 mm (6-1/2") 1,300 W Plunge Cut Circular Saw

SP6000

Continuous rating Input	1,300W
Wheel diameter	165 mm (6-1/2")
Max cutting capacity	0°: 56 mm (2-3/16") 45°: 40 mm (1-9/16") 48°: 38 mm (1-1/2")
No load speed	2,200 - 6,400 min ⁻¹
Dimensions (L x W x H)	341 x 225 x 250 mm (13-3/8 x 8-7/8 x 9-7/8")
Net weight	4.1 kg (9 lbs.)



305 mm (12") 900 W Band Saw

LB1200F

Continuous rating Input	900W
Blade length	2,240 mm (88")
Blade speed	High: (50Hz) 800 (60Hz) 1,000 m/min (50Hz) 2,624 (60Hz) 3,280 ft/min Low: (50Hz) 400 (60Hz) 500 m/min (50Hz) 1,312 (60Hz) 1,640 ft/min
Capacity	Thickness of cut: 165 mm (6-1/2") Throat: 305 mm (12")
Dimensions (L x W x H)	615 x 775 x 1,600 mm (24-1/4 x 30-1/2 x 63")
Net weight	82 kg (181.2 lbs.)



40Vmax XGT BL Cordless Top Handle Jig Saw, 3 Orbital Settings plus Straight Cutting, Twin LED Lights

JV002G

40V max

Stroke length	26 mm (1")
Strokes per minute	0 - 3,500 min ⁻¹
Capacity	Wood: 135 mm (5-5/16") Mild steel: 10 mm (3/8") Aluminum: 20 mm (13/16")
Bevel range	0 - 45°
Dimensions (L x W x H)	272 x 84 x 208 mm (10-3/4 x 3-5/16 x 8-3/16")
Net weight	2.7 - 3.0 kg (6.0 - 6.6 lbs.)



XGT BL MOTOR SOFT NOLOAD XPT



40Vmax XGT BL Cordless Barrel Handle Jig Saw, 3 Orbital Settings plus Straight Cutting, Twin LED Lights

JV001G

40V max

Stroke length	26 mm (1")
Strokes per minute	800 - 3,500 min ⁻¹
Capacity	Wood: 135 mm (5-5/16") Mild steel: 10 mm (3/8") Aluminum: 20 mm (13/16")
Bevel range	0 - 45°
Dimensions (L x W x H)	283 x 84 x 189 mm (11-1/8 x 3-5/16 x 7-7/16")
Net weight	2.6 - 2.9 kg (5.7 - 6.4 lbs.)



XGT BL MOTOR SOFT NOLOAD XPT



18V LXT BL Brushless Cordless Top Handle Jig Saw, 3 Orbital Settings Plus Straight Cutting, Twin LED Lights

DJV182

18V



Stroke length	26 mm (1")
Strokes per minute	800 - 3,500 min ⁻¹
Capacity	Wood: 135 mm (5-5/16") Steel: 10 mm (3/8")
Bevel range	0 - 45°
Dimensions (L x W x H)	266 x 77 x 208 mm (10-1/2 x 3 x 8-3/16")
Net weight	2.4 - 2.7 kg (5.2 - 5.9 lbs.)

LXT BL MOTOR SOFT NOLOAD



18V LXT BL Brushless Cordless Barrel Handle Jig Saw, 3 Orbital Settings Plus Straight Cutting, Twin LED Lights

DJV181

18V



Stroke length	26 mm (1")
Strokes per minute	800 - 3,500 min ⁻¹
Capacity	Wood: 135 mm (5-5/16") Steel: 10 mm (3/8")
Bevel range	0 - 45°
Dimensions (L x W x H)	298 x 77 x 189 mm (11-3/4 x 3 x 7-7/16")
Net weight	2.3 - 2.6 kg (5 - 5.7 lbs.)

LXT BL MOTOR SOFT NOLOAD



18V LXT Li-Ion Cordless Top Handle Jig Saw, 3 Orbital Settings Plus Straight Cutting, LED Light

DJV180

18V



Stroke length	26 mm (1")
Strokes per minute	0 - 2,600 min ⁻¹
Capacity	Wood: 135 mm (5-5/16") Steel: 10 mm (3/8")
Bevel range	0 - 45°
Dimensions (L x W x H)	257 x 73 x 208 mm (10-1/8 x 2-7/8 x 8-3/16")
Net weight	2.7 - 3 kg (6 - 6.7 lbs.)

LXT



18V LXT BL Cordless Barrel Handle Jig Saw, 3 Orbital Settings plus Straight Cutting, LED Light

DJV185

18V



Stroke length	23 mm (7/8")
Strokes per minute	800 - 3,000 min ⁻¹
Capacity	Wood: 135 mm (5-5/16") Mild steel: 10 mm (3/8") Aluminum: 20 mm (13/16")
Bevel range	0 - 45°
Dimensions (L x W x H)	w/ BL1860B: 259 x 77 x 183 mm (10-1/4 x 3 x 7-1/4")
Net weight	2.0 - 2.3 kg (4.4 - 5.1 lbs.)

LXT BL MOTOR SOFT NOLOAD XPT



18V LXT Cordless Top Handle Jig Saw, 3 Orbital Settings plus Straight Cutting

DJV186

18V

new



Stroke length	18 mm (11/16")
Strokes per minute	0 - 2,900 min ⁻¹
Capacity	Wood: 65 mm (2-9/16") Mild steel: 6 mm (1/4") Aluminum: 10 mm (3/8")
Bevel range	0 - 45°
Dimensions (L x W x H)	241 - 257 x 81 x 196 mm (9-1/2 - 10-1/8 x 3-3/16 x 7-3/4")
Net weight	1.9 - 2.2 kg (4.2 - 4.9 lbs.)

LXT



18V LXT BL Cordless Top Handle Jig Saw, 3 Orbital Settings plus Straight Cutting, LED Light

DJV184

18V



Stroke length	23 mm (7/8")
Strokes per minute	0 - 3,000 min ⁻¹
Capacity	Wood: 135 mm (5-5/16") Mild steel: 10 mm (3/8") Aluminum: 20 mm (13/16")
Bevel range	0 - 45°
Dimensions (L x W x H)	259 x 77 x 205 mm (10-1/4 x 3 x 8-1/8")
Net weight	2.1 - 2.4 kg (4.6 - 5.3 lbs.)

LXT BL MOTOR SOFT NOLOAD XPT



12V max CXT BL Brushless Cordless Top Handle Jig Saw, 3 Orbital Settings Plus Straight Cutting, LED Light

JV103D

12V max



Stroke length	23 mm (7/8")
Strokes per minute	800 - 3,000 min ⁻¹
Max cutting capacity at 0°	Wood / Aluminum / Mild Steel: 90 / 20 / 10 mm (3-1/2 / 13/16 / 3/8")
Bevel range	0 - 45°
Dimensions (L x W x H)	237 x 76 x 206 mm (9-3/8 x 3 x 8-1/8")
Net weight	1.8 kg (3.9 lbs.)

CXT BL MOTOR SOFT NOLOAD



12V max CXT BL Brushless Cordless Barrel Handle Jig Saw, 3 Orbital Settings Plus Straight Cutting, LED Light

JV102D

12V max



Stroke length	23 mm (7/8")
Strokes per minute	800 - 3,000 min ⁻¹
Max cutting capacity at 0°	Wood / Aluminum / Mild Steel: 90 / 20 / 10 mm (3-1/2 / 13/16 / 3/8")
Bevel range	0 - 45°
Dimensions (L x W x H)	237 x 76 x 186 mm (9-3/8 x 3 x 7-3/8")
Net weight	1.8 - 1.9 kg (3.9 - 4.2 lbs.)

CXT BL MOTOR SOFT NOLOAD



12V max CXT Li-Ion Cordless Top Handle Jig Saw

JV101D

12V max



Stroke length	18 mm (11/16")
Strokes per minute	0 - 2,900 min ⁻¹
Max cutting capacity at 0°	Wood / Aluminum / Mild Steel: 65 / 4 / 2 mm (2-9/16 / 5/32 / 1/16")
Bevel range	0 - 45°
Dimensions (L x W x H)	232 x 76 x 196 mm (9-1/8 x 3 x 7-3/4")
Net weight	1.7 - 3.9 kg (3.8 - 4.3 lbs.)

CXT



18V Li-Ion Cordless Top Handle Jig Saw, 3 Orbital Settings Plus Straight Cutting, G-Battery

JV183D

18V



Stroke length	18 mm (11/16")
Strokes per minute	0 - 2,900 min ⁻¹
Capacity	Wood: 65 mm (2-9/16") Steel: 6 mm (1/4") Mild steel: 6 mm (1/4") Aluminum: 10 mm (3/8")
Bevel range	0 - 45°
Dimensions (L x W x H)	248 x 76 x 196 mm (9-3/4 x 3 x 7-3/4")
Net weight	2.0 kg (4.4 lbs.)



Sawing

720 W Top Handle Jig Saw, 3 Orbital Settings Plus Straight Cutting, LED Light

4350FCT



Continuous rating Input	720W
Stroke length	26 mm (1")
Strokes per minute	800 - 2,800 min ⁻¹
Capacity	Wood: 135 mm (5-5/16") Steel: 10 mm (3/8")
Bevel range	0 - 45°
Dimensions (L x W x H)	236 x 73 x 207 mm (9-1/4 x 2-7/8 x 8-1/8")
Net weight	2.7 kg (6.0 lbs.)



720 W Top Handle Jig Saw, 3 Orbital Settings Plus Straight Cutting

4350CT



Continuous rating Input	720W
Stroke length	26 mm (1")
Strokes per minute	800 - 2,800 min ⁻¹
Capacity	Wood: 135 mm (5-5/16") Steel: 10 mm (3/8")
Bevel range	0 - 45°
Dimensions (L x W x H)	236 x 73 x 207 mm (9-1/4 x 2-7/8 x 8-1/8")
Net weight	2.7 kg (6.0 lbs.)



720 W Barrel Handle Jig Saw, 3 Orbital Settings Plus Straight Cutting, LED Light

4351FCT



Continuous rating Input	720W
Stroke length	26 mm (1")
Strokes per minute	800 - 2,800 min ⁻¹
Capacity	Wood: 135 mm (5-5/16") Steel: 10 mm (3/8")
Bevel range	0 - 45°
Dimensions (L x W x H)	271 x 73 x 187 mm (10-5/8 x 2-7/8 x 7-3/8")
Net weight	2.5 kg (5.5 lbs.)



720 W Barrel Handle Jig Saw, 3 Orbital Settings Plus Straight Cutting

4351CT



Continuous rating Input	720W
Stroke length	26 mm (1")
Strokes per minute	800 - 2,800 min ⁻¹
Capacity	Wood: 135 mm (5-5/16") Steel: 10 mm (3/8")
Bevel range	0 - 45°
Dimensions (L x W x H)	271 x 73 x 187 mm (10-5/8 x 2-7/8 x 7-3/8")
Net weight	2.5 kg (5.5 lbs.)



580 W Top Handle Jig Saw, 3 Orbital Settings Plus Straight Cutting

4350T



Continuous rating Input	580W
Stroke length	26 mm (1")
Strokes per minute	2,800 min ⁻¹
Capacity	Wood: 135 mm (5-5/16") Steel: 10 mm (3/8")
Bevel range	0 - 45°
Dimensions (L x W x H)	236 x 73 x 207 mm (9-1/4 x 2-7/8 x 8-1/8")
Net weight	2.7 kg (6.0 lbs.)



650 W Top Handle Jig Saw, 3 Orbital Settings Plus Straight Cutting

JV0600



Continuous rating Input	650W
Stroke length	23 mm (7/8")
Strokes per minute	500 - 3,100 min ⁻¹
Capacity	Wood: 90 mm (3-1/2") Steel: 10 mm (3/8")
Bevel range	0 - 45°
Dimensions (L x W x H)	236 x 77 x 199 mm (9-1/4 x 3 x 7-3/8")
Net weight	2.4 kg (5.3 lbs.)



450 W Top Handle Jig Saw, 3 Orbital Settings Plus Straight Cutting, Aluminum Die-Cast Base

4329



Continuous rating Input	450W
Stroke length	18 mm (11/16")
Strokes per minute	500 - 3,100 min ⁻¹
Capacity	Wood: 65 mm (2-9/16") Steel: 6 mm (1/4")
Bevel range	0 - 45°
Dimensions (L x W x H)	223 x 77 x 197 mm (8-3/4 x 3 x 7-3/4")
Net weight	1.9 kg (4.2 lbs.)



450 W Top Handle Jig Saw, 3 Orbital Settings Plus Straight Cutting, Steel Plate Base

4328



Continuous rating Input	450W
Stroke length	18 mm (11/16")
Strokes per minute	500 - 3,100 min ⁻¹
Max cutting capacity at 0°	Wood: 65 mm (2-9/16") Steel: 6 mm (1/4")
Bevel range	0 - 45°
Dimensions (L x W x H)	217 x 77 x 197 mm (8-1/2 x 3 x 7-3/4")
Net weight	1.8 kg (4 lbs.)



450 W Top Handle Jig Saw

4327



Continuous rating Input	450W
Stroke length	18 mm (11/16")
Strokes per minute	500 - 3,100 min ⁻¹
Capacity	Wood: 65 mm (2-9/16") Steel: 6 mm (1/4")
Bevel range	0 - 45°
Dimensions (L x W x H)	224 x 77 x 197 mm (8-7/8 x 3 x 7-3/4")
Net weight	1.9 kg (4.2 lbs.)



450 W Top Handle Jig Saw

4326



Continuous rating Input	450W
Stroke length	18 mm (11/16")
Strokes per minute	3,100 min ⁻¹
Capacity	Wood: 65 mm (2-9/16") Steel: 6 mm (1/4")
Bevel range	0 - 45°
Dimensions (L x W x H)	224 x 77 x 197 mm (8-7/8 x 3 x 7-3/4")
Net weight	1.9 kg (4.2 lbs.)



40Vmax XGT BL Cordless Recipro Saw, Chain Vise

JR003G

40V max

new



Max cutting diameter	ø220 mm (8-5/8")
Stroke length	26 mm (1")
Strokes per minute	0 - 2,200 min ⁻¹
Dimensions (L x W x H)	583 x 103 x 152 mm (23 x 4-1/16 x 6")
Net weight	4.5 - 6.8 kg (9.9 - 15.0 lbs.)



40Vmax XGT BL AVT Cordless Recipro Saw

JR002G

40V max



Max cutting diameter	ø130 mm (5-1/8")
Stroke length	32 mm (1-1/4")
Strokes per minute	0 - 3,000 min ⁻¹
Capacity	Wood: 255 mm (10") Pipe: 130 mm (5-1/8")
Dimensions (L x W x H)	436 x 97 x 250 mm (17-1/8 x 3-13/16 x 9-7/8")
Net weight	4.6 - 5.8 kg (10.1 - 12.8 lbs.)



40Vmax XGT BL Brushless Cordless Recipro Saw

JR001G

40V max



Stroke length	32 mm (1-1/4")
Strokes per minute	High / Low: 0 - 3,000 / 0 - 2,300 min ⁻¹
Capacity	Wood: 255 mm (10") Pipe: 130 mm (5-1/8")
Dimensions (L x W x H)	457 x 88 x 233 mm (18 x 3-1/2 x 9-1/8")
Net weight	4.2 - 4.5 kg (9.3 - 9.9 lbs.)



18V X2 (36V) LXT BL Brushless Cordless Recipro Saw

DJR360

18V x2



Stroke length	32 mm (1-1/4")
Strokes per minute	High / Low: 0 - 3,000 / 0 - 2,300 min ⁻¹
Capacity	Wood: 255 mm (10") Pipe: 130 mm (5-1/8")
Dimensions (L x W x H)	449 x 116 x 243 mm (17-3/4 x 4-9/16 x 9-9/16")
Net weight	4 - 4.7 kg (8.9 - 10.3 lbs.)



18V LXT BL Brushless Cordless Recipro Saw

DJR187

18V



Stroke length	32 mm (1-1/4")
Strokes per minute	High / Low: 0 - 3,000 / 0 - 2,300 min ⁻¹
Capacity	Wood: 255 mm (10") Pipe: 130 mm (5-1/8")
Dimensions (L x W x H)	439 x 88 x 231 mm (17-1/4 x 3-1/2 x 9-1/8")
Net weight	3.7 kg (8.2 lbs.)



18V LXT BL Cordless Recipro Saw

DJR189

18V



Stroke length	22 mm (7/8")
Strokes per minute	0 - 3,100 min ⁻¹
Capacity	Wood: 255 mm (10") Pipe: 130 mm (5-1/8")
Dimensions (L x W x H)	w/ BL1830B / BL1840B / BL1850B / BL1860B: 410 x 81 x 182 mm (16-1/8 x 3-3/16 x 7-1/8")
Net weight	2.2 - 2.5 kg (4.9 - 5.5 lbs.)



18V LXT BL Brushless Cordless Recipro Saw

DJR188

18V



Stroke length	20 mm (13/16")
Strokes per minute	0 - 3,000 min ⁻¹
Capacity	Wood: 255 mm (10") Pipe: 130 mm (5-1/8")
Dimensions (L x W x H)	w/ BL1830B / BL1840B / BL1850B / BL1860B: 316 x 81 x 220 mm (12-1/2 x 3-3/16 x 8-5/8")
Net weight	2.6 - 2.9 kg (5.7 - 6.4 lbs.)



18V LXT Li-Ion Cordless Recipro Saw

DJR186

18V



Stroke length	32 mm (1-1/4")
Strokes per minute	0 - 2,800 min ⁻¹
Capacity	Wood: 255 mm (10") Pipe: 130 mm (5-1/8")
Dimensions (L x W x H)	486 x 81 x 223 mm (19-1/8 x 3-3/16 x 8-3/4")
Net weight	3.5 - 3.8 kg (7.6 - 8.3 lbs.)



18V LXT Li-Ion Cordless Compact Recipro Saw

DJR183

18V



Stroke length	13 mm (1/2")
Strokes per minute	0 - 3,000 min ⁻¹
Capacity	Wood: 50 mm (2") Pipe: 50 mm (2")
Dimensions (L x W x H)	w/ BL1830B / BL1840B / BL1850B / BL1860B: 398 x 81 x 220 mm (15-5/8 x 3-3/16 x 8-5/8")
Net weight	1.5 - 1.7 kg (3.3 - 3.8 lbs.)



18V LXT Li-Ion Cordless Compact Recipro Saw

DJR185

18V



Stroke length	13 mm (1/2")
Strokes per minute	0 - 3,000 min ⁻¹
Capacity	Wood: 50 mm (2") Pipe: 50 mm (2")
Dimensions (L x W x H)	w/ BL1830B / BL1840B / BL1850B / BL1860B: 398 x 81 x 220 mm (15-5/8 x 3-3/16 x 8-5/8")
Net weight	1.5 - 1.8 kg (3.4 - 4.1 lbs.)



Sawing

12V max CXT Li-Ion Cordless Recipro Saw

JR103D

12V max



Stroke length	13 mm (1/2")
Strokes per minute	0 - 3,300 min ⁻¹
Capacity	Wood: 50 mm (2") Pipe: 50 mm (2")
Dimensions (L x W x H)	w/ BL1041B: 386 x 66 x 200 mm (15-1/4 x 2-5/8 x 7-7/8")
Net weight	1.3 - 1.5 kg (2.9 - 3.3 lbs.)

CXT



12V max CXT Li-Ion Cordless Recipro Saw

JR105D

12V max



Stroke length	13 mm (1/2")
Strokes per minute	0 - 3,300 min ⁻¹
Capacity	Wood: 50 mm (2") Pipe: 50 mm (2")

Dimensions (L x W x H)	w/ BL1041B: 386 x 66 x 200 mm (15-1/4 x 2-5/8 x 7-7/8")
Net weight	1.3 - 1.5 kg (2.9 - 3.2 lbs.)

CXT



1,510 W AVT Recipro Saw

JR3070CT



Continuous rating Input	1,510W
Stroke length	32 mm (1-1/4")
Strokes per minute	0 - 2,800 min ⁻¹
Capacity	Pipe: 130 mm (5-1/8") Wood: 255 mm (10")
Dimensions (L x W x H)	485 x 99 x 181 mm (19-1/8 x 3-7/8 x 7-1/8")
Net weight	4.6 kg (10 lbs.)

AVT



1,250 W Recipro Saw

JR3061T



Continuous rating Input	1,250W
Stroke length	32 mm (1-1/4")
Strokes per minute	0 - 3,000 min ⁻¹
Capacity	Pipe: 130 mm (5-1/8") Wood: 255 mm (10")

Dimensions (L x W x H)	487 x 95 x 177 mm (19-3/16 x 3-3/4 x 7")
Net weight	3.8 kg (8.4 lbs.)



1,200 W Recipro Saw

JR3051T



Continuous rating Input	1,200W
Stroke length	30 mm (1-3/16")
Strokes per minute	0 - 3,000 min ⁻¹
Capacity	Pipe: 130 mm (5-1/8") Wood: 255 mm (10")
Dimensions (L x W x H)	447 x 97 x 176 mm (17-5/8 x 3-13/16 x 6-15/16")
Net weight	3.3 kg (7.3 lbs.)



340 W Recipro Saw

JR1000FT



Continuous rating Input	340W
Stroke length	14 mm (9/16")
Strokes per minute	0 - 4,800 min ⁻¹
Capacity	Pipe: 25.4 mm (1") Wood: 55 mm (2-3/16")

Dimensions (L x W x H)	345 x 65 x 96 mm (13-5/8 x 2-9/16 x 3-3/4")
Net weight	1.6 kg (3.5 lbs.)



18V LXT Li-Ion Cordless Drywall Saw

DSD180

18V



Stroke length	6 mm (1/4")
Strokes per minute	0 - 6,000 min ⁻¹
Capacity	Drywall: 30 mm (1-3/16") Wood: 15 mm (9/16")
Dimensions (L x W x H)	263 x 79 x 291 mm (10-3/8 x 3-1/8 x 11-3/8")
Net weight	1.7 - 2 kg (3.8 - 4.5 lbs.)

LXT



12V max CXT Li-Ion Cordless Drywall Saw

SD100D

12V max



Stroke length	6 mm (1/4")
Strokes per minute	0 - 6,000 min ⁻¹
Capacity	Drywall: 30 mm (1-3/16") Wood: 15 mm (9/16")

Dimensions (L x W x H)	239 x 79 x 266 mm (9-3/8 x 3-1/8 x 10-1/2")
Net weight	1.4 - 1.6 kg (3.2 - 3.5 lbs.)

CXT



406 mm (16") 50 W Variable Speed Scroll Saw

SJ401













Continuous rating Input	50W
Stroke length	18 mm (11/16")
Strokes per minute	400 - 1,600 min ⁻¹
Capacity	Thickness of cut: 50 mm (2") Throat: 406 mm (16")
Overall length	600 mm (23-5/8")
Net weight	14 kg (30.87 lbs.)



Milling/Planing

Icon

-  Double Insulation
-  Variable Speed
-  Brake
-  Anti-restart function
-  Constant Speed
-  Soft Start
-  Dust Collection
-  Built-in Job Light
-  Carrying Case
-  Wooden Carrying Case

40Vmax XGT BL AWS Cordless 6 / - 8 / - mm (- / 1/4 / - / 3/8") Variable Speed Trimmer with Twin LED Lights

RT001G

40V max



No load speed	10,000 - 31,000 min ⁻¹
Collet size	6 / - 8 / - mm (- / 1/4 / - / 3/8")
Plunge capacity	w/ Trimmer base: 0 - 40 mm (0 - 1-9/16") w/ Plunge base: 0 - 35 mm (0 - 1-3/8")
Dimensions (L x W x H)	126 x 89 x 245 mm (5 x 3-1/2 x 9-5/8")
Net weight	2.0 - 2.5 kg (4.4 - 5.5 lbs.)



18V LXT BL Brushless Cordless 6 / - mm (- / 1/4") Trimmer

DRT52

18V



No load speed	30,000 min ⁻¹
Collet size	6 / - mm (- / 1/4")
Dimensions (L x W x H)	134 x 90 x 220 mm (5-1/4 x 3-1/2 x 8-5/8")
Net weight	1.3 - 1.6 kg (2.9 - 3.5 lbs.)



18V LXT BL Brushless Cordless 6 / - 8 / - mm (- / 1/4 / - / 3/8") Variable Speed Trimmer with Dual LED Lights

DRT50

18V



No load speed	10,000 - 30,000 min ⁻¹
Collet size	6 / - 8 / - mm (- / 1/4 / - / 3/8")
Base inner	30 mm (1-3/16")
Plunge capacity	w/ Trimmer base: 0 - 40 mm (0 - 1-9/16") w/ Plunge base: 0 - 35 mm (0 - 1-3/8")
Dimensions (L x W x H)	w/ BL1830B / BL1840B / BL1850B / BL1860B: 134 x 89 x 226 mm (5-1/4 x 3-1/2 x 8-7/8")
Net weight	1.8 - 2.1 kg (3.9 - 4.6 lbs.)



6 / - 8 / - mm (- / 1/4 / - / 3/8") 710 W Variable Speed Trimmer with Anti-Restart Function

RT0702C



Continuous rating Input	710W
No load speed	10,000 - 34,000 min ⁻¹
Collet size	6 / - 8 / - mm (- / 1/4 / - / 3/8")
Base inner	30 mm (1-3/16")
Plunge capacity	w/ Trimmer base: 0 - 40 mm (0 - 1-9/16") w/ Plunge base: 0 - 35 mm (0 - 1-3/8")
Dimensions (L x W x H)	89 x 89 x 210 mm (3-1/2 x 3-1/2 x 8-1/4")
Net weight	1.8 - 2.8 kg (4.0 - 6.2 lbs.)



6 / - 8 / - mm (- / 1/4 / - / 3/8") 710 W Variable Speed Trimmer

RT0700C



Continuous rating Input	710W
No load speed	10,000 - 30,000 min ⁻¹
Collet size	6 / - 8 / - mm (- / 1/4 / - / 3/8")
Base inner	30 mm (1-3/16")
Dimensions (L x W x H)	89 x 89 x 200 mm (3-1/2 x 3-1/2 x 7-7/8")
Net weight	1.8 - 2.7 kg (3.9 - 6 lbs.)



6 / - mm (- / 1/4") 530 W Tilt Base Trimmer

3712



Continuous rating Input	530W
No load speed	32,000 min ⁻¹
Collet size	6 / - mm (- / 1/4")
Base inner	28 mm (1-1/8")
Plunge capacity	0 - 42 mm (0 - 1-5/8")
Dimensions (L x W x H)	102 x 122 x 314 mm (4 x 4-13/16 x 12-3/8")
Net weight	1.7 kg (3.7 lbs.)



6 / - mm (- / 1/4") 530 W Fixed Base Trimmer

3711



Continuous rating Input	530W
No load speed	32,000 min ⁻¹
Collet size	6 / - mm (- / 1/4")
Base inner	35 mm (1-3/8")
Plunge capacity	0 - 42 mm (0 - 1-5/8")
Dimensions (L x W x H)	82 x 90 x 211 mm (3-1/4 x 3-1/2 x 8-5/16")
Net weight	1.5 kg (3.3 lbs.)



6 / - mm (- / 1/4") 530 W Tilt Base Trimmer

3710



Continuous rating Input	530W
No load speed	30,000 min ⁻¹
Collet size	6 / - mm (- / 1/4")
Base inner	28 mm (1-1/8")
Dimensions (L x W x H)	102 x 122 x 302 mm (4 x 4-13/16 x 11-7/8")
Net weight	1.5 kg (3.3 lbs.)



Milling/Planing

6 / - mm (- / 1/4") 530 W Fixed Base Trimmer

3709



Continuous rating Input	530W
No load speed	30,000 min ⁻¹
Collet size	6/ - mm (- / 1/4")
Base inner	35 mm (1-3/8")
Dimensions (L x W x H)	82 x 90 x 199 mm (3-1/4 x 3-1/2 x 7-7/8")
Net weight	1.5 kg (3.3 lbs.)



6 / - mm (- / 1/4") 440 W Trimmer

N3701



Continuous rating Input	440W
No load speed	30,000 min ⁻¹
Collet size	6/ - mm (- / 1/4")
Base inner	35 mm (1-3/8")
Overall height	181 mm (7-1/8")
Net weight	1.6 kg (3.4 lbs.)

40Vmax XGT BL AWS Cordless 12 / - mm (- / 1/2") 1,900 W Variable Speed Plunge Router with Electric Brake, Soft Start, Twin LEDs

RP001G

40V max



No load speed	8,000 - 25,000 min ⁻¹
Collet size	12 / - mm (- / 1/2")
Base size	150 x 130 mm (5-7/8 x 5-1/8")
Plunge capacity	60 mm (2-3/8")
Dimensions (L x W x H)	135 x 275 x 288 mm (5-5/16 x 10-7/8 x 11-3/8")
Net weight	4.0 - 5.2 kg (8.8 - 11.5 lbs.)

XGT BL AWS XPT



12 / - mm (- / 1/2") 2,100 W Variable Speed Plunge Router with Electric Brake, Soft Start, Twin LED Lights

RP2303FC



Continuous rating Input	2,100W
No load speed	9,000 - 23,000 min ⁻¹
Collet size	12/ - mm (- / 1/2")
Base diameter	170 x 155 mm (6-11/16 x 6-1/8")
Plunge capacity	0 - 70 mm (0 - 2-3/4")
Dimensions (L x W x H)	155 x 294 x 327 mm (6-1/8 x 11-5/8 x 12-7/8")
Net weight	6.2 kg (13.7 lbs.)



12 / - mm (- / 1/2") 2,300 W Variable Speed Plunge Router with Soft Start, Twin LED Lights

RP2302FC



Continuous rating Input	2,300W
No load speed	9,000 - 23,000 min ⁻¹
Collet size	12/ - mm (- / 1/2")
Base diameter	170 x 155 mm (6-11/16 x 6-1/8")
Plunge capacity	0 - 70 mm (0 - 2-3/4")
Dimensions (L x W x H)	155 x 294 x 327 mm (6-1/8 x 11-5/8 x 12-7/8")
Net weight	6.2 kg (13.7 lbs.)



6 / - 8 / - 10 / 12 / - mm (- / 1/4 / - 3/8 / - / - 1/2") 2,300 W Variable Speed Plunge Router with Soft Start, Dual LED Lights

RP2300FC



Continuous rating Input	2,300W
No load speed	9,000 - 22,000 min ⁻¹
Collet size	6/ - 8 / - 10 / 12 / - mm (- / 1/4 / - 3/8 / - / - 1/2")
Base diameter	170 x 155 mm (6-11/16 x 6-1/8")
Base inner	62 mm (2-7/16")
Plunge capacity	0 - 70 mm (0 - 2-3/4")
Dimensions (L x W x H)	155 x 294 x 312 mm (6-1/8 x 11-5/8 x 12-1/4")
Net weight	6.1 kg (13.5 lbs.)



6 / - 8 / - 10 / 12 / - mm (- / 1/4 / - 3/8 / - / - 1/2") 2,100 W Variable Speed Plunge Router with Electric Brake, Soft Start, Dual LED Lights

RP2301FC



Continuous rating Input	2,100W
No load speed	9,000 - 22,000 min ⁻¹
Collet size	6/ - 8 / - 10 / 12 / - mm (- / 1/4 / - 3/8 / - / - 1/2")
Base diameter	170 x 155 mm (6-11/16 x 6-1/8")
Base inner	62 mm (2-7/16")
Plunge capacity	0 - 70 mm (0 - 2-3/4")
Dimensions (L x W x H)	155 x 294 x 312 mm (6-1/8 x 11-5/8 x 12-1/4")
Net weight	6.1 kg (13.5 lbs.)



12 / - mm (- / 1/2") 1,850 W Plunge Router with Soft Start, Twin LED Lights

RP1802F



Continuous rating Input	1,850W
No load speed	23,000 min ⁻¹
Collet size	12/ - mm (- / 1/2")
Base diameter	170 x 155 mm (6-11/16 x 6-1/8")
Plunge capacity	0 - 70 mm (0 - 2-3/4")
Dimensions (L x W x H)	155 x 294 x 312 mm (6-1/8 x 11-5/8 x 12-1/4")
Net weight	6.2 kg (13.7 lbs.)



12 / - mm (- / 1/2") 1,850 W Plunge Router with Soft Start

RP1802



Continuous rating Input	1,850W
No load speed	23,000 min ⁻¹
Collet size	12/ - mm (- / 1/2")
Base diameter	170 x 155 mm (6-11/16 x 6-1/8")
Plunge capacity	0 - 70 mm (0 - 2-3/4")
Dimensions (L x W x H)	155 x 294 x 312 mm (6-1/8 x 11-5/8 x 12-1/4")
Net weight	6.2 kg (13.7 lbs.)



12 / - mm (- / 1/2") 1,650 W Plunge Router with Electric Brake, Soft Start, Twin LED Lights

RP1803F



Continuous rating Input	1,650W
No load speed	22,000 min ⁻¹
Collet size	12/ - mm (- / 1/2")
Base diameter	170 x 155 mm (6-11/16 x 6-1/8")
Plunge capacity	0 - 70 mm (0 - 2-3/4")
Dimensions (L x W x H)	155 x 294 x 312 mm (6-1/8 x 11-5/8 x 12-1/4")
Net weight	6.2 kg (13.7 lbs.)



12 / - mm (- / 1/2") 1,650 W Plunge Router with Electric Brake, Soft Start

RP1803



Continuous rating Input	1,650W
No load speed	22,000 min ⁻¹
Collet size	12 / - mm (- / 1/2")
Base diameter	170 x 155 mm (6-11/16 x 6-1/8")
Plunge capacity	0 - 70 mm (0 - 2-3/4")
Dimensions (L x W x H)	155 x 294 x 312 mm (6-1/8 x 11-5/8 x 12-1/4")
Net weight	6.2 kg (13.7 lbs.)



6 / - / 8 / - / 10 / 12 / - mm (- / 1/4 / - / 3/8 / - / - / 1/2") 1,850 W Plunge Router with Dual LED Lights

RP1800F



Continuous rating Input	1,850W
No load speed	22,000 min ⁻¹
Collet size	6 / - / 8 / - / 10 / 12 / - mm (- / 1/4 / - / 3/8 / - / - / 1/2")
Base diameter	170 x 155 mm (6-11/16 x 6-1/8")
Base inner	62 mm (2-7/16")
Plunge capacity	0 - 70 mm (0 - 2-3/4")
Dimensions (L x W x H)	155 x 294 x 312 mm (6-1/8 x 11-5/8 x 12-1/4")
Net weight	6 kg (13.2 lbs.)



6 / - / 8 / - / 10 / 12 / - mm (- / 1/4 / - / 3/8 / - / - / 1/2") 1,850 W Plunge Router

RP1800



Continuous rating Input	1,850W
No load speed	22,000 min ⁻¹
Collet size	6 / - / 8 / - / 10 / 12 / - mm (- / 1/4 / - / 3/8 / - / - / 1/2")
Base diameter	170 x 155 mm (6-11/16 x 6-1/8")
Base inner	62 mm (2-7/16")
Plunge capacity	0 - 70 mm (0 - 2-3/4")
Dimensions (L x W x H)	155 x 294 x 312 mm (6-1/8 x 11-5/8 x 12-1/4")
Net weight	6 kg (13.2 lbs.)



6 / - / 8 / - / 10 / 12 / - mm (- / 1/4 / - / 3/8 / - / - / 1/2") 1,500 W D-Handle Router

3600H



Continuous rating Input	1,500W
No load speed	24,000 min ⁻¹
Collet size	6 / - / 8 / - / 10 / 12 / - mm (- / 1/4 / - / 3/8 / - / - / 1/2")
Base diameter	160 mm (6-1/4")
Base inner	40 mm (1-9/16")
Overall height	210 mm (8-1/4")
Net weight	4.4 kg (9.8 lbs.)

- / - mm (1/4 / 1/2") 1,250 W Variable Speed Plunge Router with Soft Start

RP1101



Continuous rating Input	1,250W
No load speed	8,000 - 24,000 min ⁻¹
Collet size	- / - mm (1/2 / 1/4")
Base inner	30.5 mm (1-3/16")
Plunge capacity	0 - 66 mm (2 - 19/32")
Overall height	291 mm (11-1/2")
Net weight	4.3 kg (9.4 lbs.)



- / - mm (1/4 / 1/2") 1,100 W Variable Speed D-Handle Router with Soft Start

RD1101



Continuous rating Input	1,100W
No load speed	8,000 - 24,000 min ⁻¹
Collet size	- / - mm (1/2 / 1/4")
Base inner	30.5 mm (1-3/16")
Plunge capacity	0 - 55 mm (0 - 2-3/16")
Overall height	223 mm (8-3/4")
Net weight	3.4 kg (7.4 lbs.)



- / - mm (1/4 / 1/2") 1,100 W Variable Speed Router with Soft Start

RF1101



Continuous rating Input	1,100W
No load speed	8,000 - 24,000 min ⁻¹
Collet size	- / - mm (1/2 / 1/4")
Base inner	30.5 mm (1-3/16")
Plunge capacity	0 - 55 mm (0 - 2-3/16")
Overall height	223 mm (8-3/4")
Net weight	3.3 kg (7.3 lbs.)



6 / - / 8 mm (- / 1/4 / -") 1,100 W Variable Speed Plunge Router with Soft Start

RP1111C



Continuous rating Input	1,100W
No load speed	8,000 - 27,500 min ⁻¹
Collet size	6 / - / 8 mm (- / 1/4 / -")
Base inner	64 mm (2-1/2")
Plunge capacity	0 - 57 mm (0 - 2-1/4")
Dimensions (L x W x H)	110 x 269 x 260 mm (4-5/16 x 10-5/8 x 10-1/4")
Net weight	3.3 kg (7.3 lbs.)



6 / - / 8 mm (- / 1/4 / -") 900 W Plunge Router

RP0910



Continuous rating Input	900W
No load speed	27,000 min ⁻¹
Collet size	6 / - / 8 mm (- / 1/4 / -")
Base inner	64 mm (2-1/2")
Plunge capacity	0 - 57 mm (2 - 1/4")
Dimensions (L x W x H)	110 x 269 x 260 mm (4-5/16 x 10-5/8 x 10-1/4")
Net weight	3.3 kg (7.3 lbs.)



6 / - / 8 mm (- / 1/4 / -") 900 W Plunge Router

RP0900



Continuous rating Input	900W
No load speed	27,000 min ⁻¹
Collet size	6 / - / 8 mm (- / 1/4 / -")
Base inner	64 mm (2-1/2")
Plunge capacity	0 - 35 mm (0 - 1-3/8")
Dimensions (L x W x H)	110 x 256 x 217 mm (4-5/16 x 10-3/32 x 8-17/32")
Net weight	2.7 kg (6 lbs.)



Milling/Planing

1,140 W Chain Mortiser

7104L



Continuous rating Input	1,140W
No load speed	3,200 min ⁻¹
Capacity	Max hole width: 130 mm (5-1/8") Max hole depth: 155 mm (6-1/8")
Dimensions (L x W x H)	512 x 298 x 513 mm (20-3/16 x 11-3/4 x 20-1/4")
Net weight	17.8 - 18.2 kg (39.4 - 40.1 lbs.)



18V LXT Li-Ion Cordless Plate Joiner

DPJ180

18V

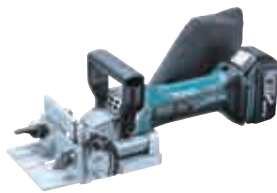

Wheel diameter	100 mm (4")
Hole diameter	22 mm (7/8")
No load speed	6,500 min ⁻¹
Dimensions (L x W x H)	351 x 139 x 149 mm (13-3/4 x 5-1/2 x 5-7/8")
Net weight	2.8 - 3.1 kg (6.2 - 6.8 lbs.)

LXT



701 W Plate Joiner

PJ7000



Continuous rating Input	701W
Wheel diameter	100 mm (4")
Hole diameter	22 mm (7/8")
No load speed	11,000 min ⁻¹
Dimensions (L x W x H)	302 x 139 x 145 mm (11-7/8 x 5-1/2 x 5-3/4")
Net weight	2.8 kg (6.2 lbs.)



40Vmax XGT BL AWS Cordless 82mm (3-1/4") Planer

KP001G

40V max



Planing width	82 mm (3-1/4")
Planing depth	4 mm (5/32")
Shiplapping	25 mm (1")
No load speed	15,000 min ⁻¹
Dimensions (L x W x H)	w/ BL4080F: 424 x 156 x 175 mm (16-3/4 x 6-1/8 x 6-7/8")
Net weight	3.7 - 4.9 kg (8.2 - 10.8 lbs.)

XGT MOTOR BL AWS XPT



18V LXT BL AWS ADT Cordless 82 mm (3-1/4") Planer

DKP181

18V



Planing width	82 mm (3-1/4")
Planing depth	3 mm (1/8")
Shiplapping	25 mm (1")
No load speed	12,000 min ⁻¹
Dimensions (L x W x H)	w/ BL1830B / BL1840B / BL1850B / BL1860B: 366 x 156 x 166 mm (14-3/8 x 6-1/8 x 6-1/2")
Net weight	3.3 - 3.6 kg (7.3 - 7.9 lbs.)

LXT MOTOR BL ADT AWS



18V LXT Li-Ion Cordless 82 mm (3-1/4") Planer

DKP180

18V



Planing width	82 mm (3-1/4")
Planing depth	2.0 mm (5/64")
Shiplapping	9 mm (11/32")
No load speed	15,000 min ⁻¹
Dimensions (L x W x H)	w/ BL1830B / BL1840B / BL1850B / BL1860B: 333 x 157 x 160 mm (13-1/8 x 6-3/16 x 6-5/16")
Net weight	3.2 - 3.5 kg (7.1 - 7.9 lbs.)

LXT



155 mm (6-1/8") 1,140 W Power Planer

1805N



Continuous rating Input	1,140W
Planing width	155 mm (6-1/8")
Planing depth	3 mm (1/16")
No load speed	15,000 min ⁻¹
Overall length	445 mm (17-1/2")
Net weight	7.9 kg (17.3 lbs.)



136 mm (5-3/8") 960 W Power Planer

1804N



Continuous rating Input	960W
Planing width	136 mm (5-3/8")
Planing depth	3 mm (1/8")
No load speed	16,000 min ⁻¹
Overall length	445 mm (17-1/2")
Net weight	7.8 kg (17.2 lbs.)



110 mm (4-5/16") 840 W Power Planer

1911B



Continuous rating Input	840W
Planing width	110 mm (4-5/16")
Planing depth	2 mm (1/16")
No load speed	16,000 min ⁻¹
Overall length	355 mm (14")
Net weight	4.1 kg (9.1 lbs.)



Milling/Planing

82 mm (3-1/4") 1,050 W Power Planer

KP0810C



Continuous rating Input	1,050W
Planing width	82 mm (3-1/4")
Planing depth	4 mm (5/32")
Shiplapping	25 mm (1")
No load speed	12,000 min ⁻¹
Dimensions (L x W x H)	290 x 168 x 176 mm (11-3/8 x 6-5/8 x 6-15/16")
Net weight	3.4 kg (7.5 lbs.)



82 mm (3-1/4") 850 W Power Planer

KP0810



Continuous rating Input	850W
Planing width	82 mm (3-1/4")
Planing depth	4 mm (5/32")
Shiplapping	25 mm (1")
No load speed	16,000 min ⁻¹
Dimensions (L x W x H)	290 x 168 x 176 mm (11-3/8 x 6-5/8 x 6-15/16")
Net weight	3.3 kg (7.3 lbs.)



82 mm (3-1/4") 620 W Planer

KP0800



Continuous rating Input	620W
Planing width	82 mm (3-1/4")
Planing depth	2.5 mm (3/32")
Shiplapping	9 mm (11/32")
No load speed	17,000 min ⁻¹
Dimensions (L x W x H)	285 x 158 x 158 mm (11-1/4 x 6-1/4 x 6-1/4")
Net weight	2.8 kg (6.2 lbs.)



312 mm (12-1/4") 2,200 W Planer

KP312S



Continuous rating Input	2,200W
Planing Width	312 mm (12-1/4")
Cutting depth	Cutting width 0 - 150 mm: 3.5 mm (1/8") Cutting width 150 - 240 mm: 2.0 mm (1/16") Cutting width 240 - 312 mm: 1.5 mm (1/16")
No load speed	12,000 min ⁻¹
Overall length	551 mm (21-3/4")
Net weight	18.4 kg (40.6 lbs.)



312 mm (12-1/4") 1,700 W Planer

KP312



Continuous rating Input	1,700W
Planing Width	312 mm (12-1/4")
Cutting depth	Cutting width 0 - 150 mm: 3.5 mm (1/8") Cutting width 150 - 240 mm: 2.0 mm (1/16") Cutting width 240 - 312 mm: 1.5 mm (1/16")
No load speed	12,000 min ⁻¹
Dimensions (L x W x H)	551 x 425 x 219 mm (21-3/4 x 16-3/4 x 8-5/8")
Net weight	18.4 kg (40.6 lbs.)



304 mm (12") 1,650 W Planer

2012NB



Continuous rating Input	1,650W
Planing Width	304 mm (12")
Cutting depth	Cutting width 0 - 150 mm: 3 mm (1/8") Cutting width 150 - 240 mm: 1.5 mm (1/16")
Feed rate/min.	8.5 m (27.9 ft)
No load speed	8,500 min ⁻¹
Table size (L x W)	771 x 304 mm (30-3/8 x 12")
Dimensions (L x W x H)	483 x 771 x 401 mm (19 x 30-3/8 x 15-13/16")
Net weight	27.1 - 27.6 kg (59.7 - 60.9 lbs.)



125 mm (5") 1,400 W Concrete Planer

PC5000C



Continuous rating Input	1,400W
Wheel diameter	125 mm (5")
Hole diameter	22.23 mm (7/8")
No load speed	10,000 min ⁻¹
Dimensions (L x W x H)	437 x 235 x 195 mm (17-1/8 x 9-1/4 x 7-5/8")
Net weight	4 kg (8.9 lbs.)



125 mm (5") 1,400 W Concrete Planer

PC5001C



Continuous rating Input	1,400W
Wheel diameter	125 mm (5")
Hole diameter	22.23 mm (7/8")
No load speed	10,000 min ⁻¹
Dimensions (L x W x H)	479 x 182 x 195 mm (18-13/16 x 7-1/8 x 7-5/8")
Net weight	4 kg (8.9 lbs.)



125 mm (5") 1,400 W SJS II Variable Speed Concrete Planer

PC5010C



Continuous rating Input	1,400W
Wheel diameter	125 mm (5")
Hole diameter	22.23 mm (7/8")
No load speed	4,000 - 9,000 min ⁻¹
Dimensions (L x W x H)	350 x 231 x 179 mm (13-3/4 x 9-1/8 x 7")
Net weight	2.5 - 3.6 kg (5.5 - 7.9 lbs.)



110 mm (4-3/8") 1,050 W Curved Planer

1002BA



Continuous rating Input	1,050W
Planing width	110 mm (4-3/8")
Planing depth	4 mm (5/32")
Max curved radial cuts	Concave: 300 mm (11-13/16")
No load speed	15,000 min ⁻¹
Overall length	339 mm (13-5/16")
Net weight	5.2 kg (11.4 lbs.)



Milling/Planing

18V LXT BL AWS Cordless 6.35 mm (1/4") Cut-Out Tool

DCO181

18V



Collet capacity	3/-/6/- mm (-/1/8-/1/4")
No load speed	32,000 min ⁻¹
Circumference of grip portion	210 mm (8-1/4")
Dimensions (L x W x H)	w/ BL1830B / BL1840B / BL1850B / BL1860B: 311 x 79 x 117 mm (12-1/4 x 3-1/8 x 4-5/8")
Net weight	1.4 - 1.7 kg (3.1 - 3.7 lbs.)

LXT BL AWS XPT



18V LXT Li-Ion Cordless 6.35 mm (1/4") Cut-Out Tool

DCO180

18V



Collet capacity	3.18, 6.35 mm or 1/8, 1/4"
No load speed	30,000 min ⁻¹
Dimensions (L x W x H)	296 x 77 x 118 mm (11-5/8 x 3 x 4-5/8")
Net weight	1.5 - 1.8 kg (3.3 - 4 lbs.)

LXT



6.35 mm (1/4") 550 W Cut-Out Tool

3706



Continuous rating Input	550W
Collet capacity	3.18, 6.35 mm or 1/8, 1/4"
No load speed	32,000 min ⁻¹
Overall height	250 mm (9-7/8")
Net weight	1.1 kg (2.4 lbs.)



Icon

- Brake
- Anti-restart function
- Torque Setting 6
- Depth Adjustment
- Sequential and Bump-fire
- Wire Collated Nail
- Sheet Collated Nail
- Inlet Filter
- Auto Firing Stop
- Built-in Job Light
- Carrying Case

18V LXT BL Brushless Cordless Rivet Gun

DRV250

18V



Pulling force	20 kN (4,500 lbs.)
Stroke	30 mm (1-3/16")
Rivet diameter range	2.4 - 6.4 mm (3/32 - 1/4")
Center height	26 mm (1")
Work amount	w/ BL1860B: 1,900 pcs
Dimensions (L x W x H)	w/ BL1830B / BL1840B / BL1850B / BL1860B: 323 x 80 x 287 mm (12-3/4 x 3-1/8 x 11-1/4")
Net weight	2.1 - 2.4 kg (4.6 - 5.3 lbs.)

LXT BL MOTOR XPT



18V LXT BL Brushless Cordless Rivet Gun

DRV150

18V



Pulling force	10 kN (2,200 lbs.)
Stroke	25 mm (1")
Rivet diameter range	2.4 - 4.8 mm (3/32 - 3/16")
Center height	26 mm (1")
Work amount	w/ BL1860B: 2,800 pcs
Dimensions (L x W x H)	w/ BL1830B / BL1840B / BL1850B / BL1860B: 313 x 80 x 287 mm (12-3/8 x 3-1/8 x 11-1/4")
Net weight	1.9 - 2.2 kg (4.2 - 4.9 lbs.)

LXT BL MOTOR XPT



40Vmax XGT BL Cordless Rebar Tying Tool

TR001G

40V max

new



Applicable rebar for tying	D10 x D10 - (D16 x 2) x (D16 x 2)
Applicable tie wire	Annealed wire: 16Ga (1.6 mm)
Tying speed	0.7 s
Number of ties	Per reel: 240 On a full battery charge (BL4004): 3,900
Wire tail height	16 mm (5/8")
Nose width	5.6 mm (7/32")
Dimensions (L x W x H)	375 x 113 x 331 mm (14-3/4 x 4-7/16 x 13")
Net weight	3.3 - 4.5 kg (7.3 - 9.9 lbs.)

XGT BL MOTOR XPT



18V LXT BL Brushless Cordless Rebar Tying Tool

DTR181

18V



Applicable rebar for tying	D16 x D16 - (D13 x 2) x (D16 x 2)
Applicable tie wire	Annealed wire: 21Ga (0.8 mm) Galvanized wire: 21Ga (0.8 mm) Poly coated wire: 20Ga (0.9 mm)
Tying speed	1.3 s
Number of ties	Per reel: 75
Wire tail height	21 mm (13/16")
Nose width	14.0 mm (9/16")
Dimensions (L x W x H)	w/ BL1830B / BL1840B / BL1850B / BL1860B: 317 x 93 x 318 mm (12-1/2 x 3-5/8 x 12-1/2")
Net weight	2.4 - 2.7 kg (5.3 - 6.0 lbs.)

LXT BL MOTOR XPT



18V LXT BL Brushless Cordless Rebar Tying Tool

DTR180

18V



Applicable rebar for tying	D10 x D10 - (D13 x 2) x (D13 x 2)
Applicable tie wire	Annealed wire: 21Ga (0.8 mm) Galvanized wire: 21Ga (0.8 mm) Poly coated wire: 20Ga (0.9 mm)
Tying speed	0.9 s
Number of ties	Per reel: 120
Wire tail height	21 mm (13/16")
Nose width	14.0 mm (9/16")
Dimensions (L x W x H)	w/ BL1830B / BL1840B / BL1850B / BL1860B: 304 x 93 x 318 mm (12 x 3-2/3 x 12-1/2")
Net weight	2.3 - 2.6 kg (5.1 - 5.7 lbs.)

LXT BL MOTOR XPT



40Vmax XGT Li-Ion Brushless Cordless 90 mm (3-1/2") Framing Nailer, Clipped-Head

BN001G

40V max

new



Nail capacity	Length: 50 - 90 mm (2 - 3-1/2") Gauge: 2.9 - 3.3 mm (0.113 - 0.131") Collation angle display: 30 - 34 ° Max magazine capacity: 58 nails
Work volume on a full battery charge (Battery)	1,020 BL4025
Rapid firing capability	4 per second
Dimensions (L x W x H)	326 x 186 x 358 mm (12-7/8 x 7-3/8 x 14-1/8")
Net weight	5.3 - 6.5 kg (11.7 - 14.3 lbs.)

XGT BL MOTOR XPT



40Vmax XGT Li-Ion Brushless Cordless 90 mm (3-1/2") Framing Nailer, Round-head

BN002G

40V max

new



Nail capacity	Length: 50 - 90 mm (2 - 3-1/2") Gauge: 2.9 - 3.8 mm (0.113 - 0.148") Collation angle display: 21 ° Max magazine capacity: 41 nails
Work volume on a full battery charge (Battery)	1,020 BL4025
Rapid firing capability	4 per second
Dimensions (L x W x H)	389 x 189 x 358 mm (15-1/4 x 7-7/16 x 14-1/8")
Net weight	5.4 - 6.6 kg (11.9 - 14.6 lbs.)

XGT BL MOTOR XPT



Fastening/Fixing

18V LXT Li-Ion Cordless 90 mm (3-1/2") Framing Nailer, Clipped-Head

DBN900

18V



Nail capacity	Length: 50 - 90 mm (2 - 3-1/2") Gauge: 2.9 - 3.3 mm (0.113 - 0.131") Collation angle display: 30 - 34° Max magazine capacity: 58 nails
Work volume on a full battery charge (Battery)	BL1860B
Rapid firing capability per second	2
Dimensions (L x W x H)	326 x 186 x 358 mm (12-7/8 x 7-3/8 x 14-1/8")
Net weight	4.9 - 5.4 kg (10.8 - 11.9 lbs.)

LXT BL MOTOR XPT



18V LXT Li-Ion Cordless 90 mm (3-1/2") Framing Nailer, Round-Head

DBN901

18V



Nail capacity	Length: 50 - 90 mm (2 - 3-1/2") Gauge: 2.9 - 3.8 mm (0.113 - 0.148") Collation angle display: 21° Max magazine capacity: 41 nails
Work volume on a full battery charge (Battery)	BL1860B
Rapid firing capability per second	2
Dimensions (L x W x H)	389 x 189 x 358 mm (15-1/4 x 7-7/16 x 14-1/8")
Net weight	5.0 - 5.4 kg (11.0 - 11.9 lbs.)

LXT BL MOTOR XPT



90 mm (3-1/2") Pneumatic Framing Nailer (For clipped-head nails)

AN943



Nail capacity	50 - 90 mm (2 - 3-1/2")
Operating pressure	0.44 - 0.83 MPa (65 - 120 PSI)
Magazine capacity	60 - 84
Dimensions (L x W x H)	455 x 109 x 365 mm (17-7/8 x 4-1/4 x 14-3/8")
Net weight	4 kg (8.8 lbs.)



90 mm (3-1/2") Pneumatic Framing Nailer, 21° Full Round Head

AN924



Nail capacity	50 - 90 mm (2 - 3-1/2")
Capacity	Dia.: 2.9 - 3.76 mm (0.113 - 0.148") Angle: 21°
Operating pressure	0.49 - 0.83 MPa (70 - 120 PSI)
Magazine capacity	64 - 73 nails
Driving stroke	126 mm (5")
Cylinder bore diameter	57 mm (2-1/4")
Dimensions (L x W x H)	560 x 117 x 348 mm (22 x 4-5/8 x 13-3/4")
Net weight	3.8 kg (8.3 lbs.)



100 mm Pneumatic Pallet Coil Nailer

AN960



Capacity	Length: 57 - 100 mm
Magazine capacity	225 - 300
Operating pressure	0.49 - 0.83 MPa (71 - 120 PSI)
Dimensions (L x W x H)	338 x 153 x 418 mm (7-1/2 x 6 x 16-1/2")
Net weight	5.1 kg (11.2 lbs.)



100 mm Pneumatic Pallet Coil Nailer

AN961



Capacity	Length: 55 - 100 mm
Magazine capacity	225 - 300
Operating pressure	0.49 - 0.83 MPa (71 - 120 PSI)
Dimensions (L x W x H)	338 x 153 x 418 mm (7-1/2 x 6 x 16-1/2")
Net weight	5.3 kg (11.7 lbs.)



75 mm (2-15/16") Pneumatic Pallet Coil Nailer

AN760



Capacity	Length: 45 - 75 mm (1-3/4 - 2-15/16") Wire: 2.3 - 3.3 mm (0.0915 - 0.130")
Magazine capacity	200 - 300
Operating pressure	0.49 - 0.83 MPa (70 - 120 PSI)
Dimensions (L x W x H)	312 x 131 x 331 mm (12-1/4 x 5-1/8 x 13")
Net weight	3.2 kg (7.1 lbs.)



50 mm (2") Pneumatic Pallet Coil Nailer

AN560



Capacity	Length: 27 - 50 mm (1-1/16 - 2") Wire: 2.1 mm (3/32")
Magazine capacity	350 - 400
Operating pressure	0.49 - 0.78 MPa (70 - 115 PSI)
Dimensions (L x W x H)	300 x 127 x 280 mm (11-3/4 x 5 x 11")
Net weight	2.1 kg (4.6 lbs.)



65 mm (2-9/16") Pneumatic Coil Nailer

AN613



Capacity	Length: 38 - 65 mm (1-1/2 - 2-9/16") Gauge: 2.3 - 2.5 mm (3/32")
Operating pressure	0.49 - 0.83 MPa (70 - 120 PSI)
Magazine capacity	200 - 300
Dimensions (L x W x H)	275 x 127 x 319 mm (10-7/8 x 5 x 12-1/2")
Net weight	2.2 kg (4.9 lbs.)



45 mm (1-3/4") Pneumatic Coil Nailer

AN454



Capacity	Length: 19 - 45 mm (3/4 - 1-3/4") Nail gauge: 3.05 mm (0.120")
Driving stroke	82 mm
Cylinder bore diameter	41.6 mm (1-5/8")
Operating pressure	0.49 - 0.83 MPa (70 - 120 PSI)
Magazine capacity	120
Dimensions (L x W x H)	w/ Hook: 256 x 142 x 271 mm (10-1/8 x 5-5/8 x 10-5/8")
Net weight	2.4 kg (5.2 lbs.)



Fastening/Fixing

18V LXT Li-Ion Cordless 15 Ga 64 mm (2-1/2") Finish Nailer

DBN620

18V

new



Nail capacity	Length: 32 - 64 mm (1-1/4 - 2-1/2") Gauge: 15 Ga Max magazine capacity: 108 nails
Capacity	Collation angle display: 34°
Shot q'ty on a single full battery charge (Battery)	800 pcs BL1820B
Quick response (pcs per second)	3.2 BL1820B
Dimensions (L x W x H)	297 x 142 x 338 mm (11-3/4 x 5-5/8 x 13-1/4")
Net weight	3.1 kg (6.8 lbs.)

LXT BL MOTOR XPT



15 GA 64 mm (2-1/2") Pneumatic Finish Nailer, Air Duster

AF635



Capacity	Length: 32 - 64 mm (1-1/4 - 2-1/2") Gauge: 15 Ga
Operating pressure	0.49 - 0.83 MPa (70 - 120 PSI)
Magazine capacity	100
Dimensions (L x W x H)	339 x 100 x 309 mm (13-3/8 x 3-15/16 x 12-1/8")
Net weight	1.8 kg (4 lbs.)



18V LXT Cordless 16 Ga 64 mm (2-1/2") Finish Nailer

DBN601

18V

new



Nail capacity	Length: 19 - 64 mm (3/4 - 2-1/2") Gauge: 16 Ga Max magazine capacity: 110 nails
Shot q'ty on a single full battery charge (Battery)	1,100 pcs BL1820B
Dimensions (L x W x H)	276 x 98 x 320 mm (10-7/8 x 3-7/8 x 12-5/8")
Net weight	2.9 - 3.3 kg (6.4 - 7.3 lbs.)

LXT BL MOTOR XPT



18V LXT Cordless 16 Ga 64 mm (2-1/2") Finish Nailer

DBN610

18V

new



Nail capacity	Length: 32 - 64 mm (1-1/4 - 2-1/2") Gauge: 16 Ga Max magazine capacity: 110 nails
Capacity	Collation angle display: 20°
Shot q'ty on a single full battery charge (Battery)	1,100 pcs BL1820B
Dimensions (L x W x H)	288 x 116 x 325 mm (11-3/8 x 4-9/16 x 12-3/4")
Net weight	3.0 - 3.3 kg (6.6 - 7.3 lbs.)

LXT BL MOTOR XPT



16 GA 64 mm (2-1/2") Pneumatic Finish Nailer, Air Duster

AF601



Capacity	Length: 25 - 64 mm (1 - 2-1/2") Gauge: 16 Ga
Operating pressure	0.49 - 0.83 MPa (70 - 120 PSI)
Magazine capacity	100
Dimensions (L x W x H)	304 x 95 x 297 mm (12 x 3-3/4 x 11-3/4")
Net weight	1.7 kg (3.8 lbs.)



18V LXT Cordless 18 Ga 50 mm (2") Brad Nailer

DBN501

18V

new



Nail capacity	Length: 15 - 50 mm (9/16 - 2") Gauge: 18 Ga Max magazine capacity: 110 nails
Shot q'ty on a single full battery charge (Battery)	1,700 pcs BL1820B
Dimensions (L x W x H)	246 x 96 x 301 mm (9-11/16 x 3-3/4 x 11-7/8")
Net weight	2.7 - 3.0 kg (6.0 - 6.6 lbs.)

LXT BL MOTOR XPT



18 Ga 50 mm (2") Pneumatic Brad Nailer, Air Duster

AF506



Nail capacity	Length: 15 - 50 mm (5/8 - 2") Gauge: 18 Ga
Operating pressure	0.49 - 0.83 MPa (70 - 120 PSI)
Magazine capacity	100
Dimensions (L x W x H)	250 x 70 x 256 mm (9-7/8 x 2-3/4 x 10-1/8")
Net weight	1.3 kg (2.9 lbs.)



40Vmax XGT BL Cordless 18 Ga 40 mm (1-5/8") Brad Nailer

FN001G

40V max



Nail capacity	Length: 15 - 40 mm (5/8 - 1-5/8") Gauge: 18 Ga
Magazine capacity	100 nails
Shot q'ty on a single full battery charge	w/ BL4025: 5,000
Dimensions (L x W x H)	w/ BL4050F: 291 x 86 x 263 mm (11-1/2 x 3-3/8 x 10-3/8")
Net weight	2.6 - 3.2 kg (5.7 - 7.1 lbs.)

XGT BL MOTOR XPT



18V LXT Li-Ion Cordless 18 Ga 35 mm (1-3/8") Brad Nailer

DFN350

18V



Nail capacity	Length: 15 - 35 mm (5/8 - 1-3/8") Gauge: 18 Ga
Magazine capacity	110 nails
Shot q'ty on a single full battery charge	w/ BL1850B: 4,000
Dimensions (L x W x H)	w/ BL1830B / BL1840B / BL1850B / BL1860B: 257 x 79 x 228 mm (10-1/8 x 3-1/8 x 9")
Net weight	2.1 - 2.4 kg (4.6 - 5.3 lbs.)

LXT XPT



Fastening/Fixing

40Vmax XGT BL 23 GA 35 mm (1-3/8") Pin Nailer

PT001G

40V max



Capacity	Length: 15, 18, 25, 30, 35 mm (5/8, 11/16, 1, 1-3/16, 1-3/8") Dia.: 0.6 mm (1/32") Gauge: 23 Ga
Magazine capacity	120 pcs
Approx. work volume on a full battery charge (Battery)	6,000 shots BL4025
Dimensions (L x W x H)	w/ BL4050F: 291 x 86 x 253 mm (11-1/2 x 3-3/8 x 10")
Net weight	2.4 - 3.0 kg (5.3 - 6.6 lbs.)



18V LXT Li-Ion Cordless 23 GA 35 mm (1-3/8") Pin Nailer

DPT353

18V



Capacity	Length: 15, 18, 25, 30, 35 mm (5/8, 11/16, 1, 1-3/16, 1-3/8") Dia.: 0.6 mm (1/32") Gauge: 23 Ga
Magazine capacity	120
Dimensions (L x W x H)	257 x 79 x 226 mm (10-1/8 x 3-1/8 x 8-7/8")
Net weight	2 - 2.3 kg (4.4 - 5.1 lbs.)



12V max CXT Li-Ion Cordless 23 GA 35 mm (1-3/8") Pin Nailer

PT354D

12V max



Capacity	Length: 15, 18, 25, 30, 35 mm (5/8, 11/16, 1, 1-3/16, 1-3/8") Dia.: 0.6 mm (1/32") Gauge: 23 Ga
Magazine capacity	120
Dimensions (L x W x H)	231 x 66 x 226 mm (9-1/8 x 2-5/8 x 8-7/8")
Net weight	1.8 - 2 kg (4 - 4.4 lbs.)



23 GA 35 mm (1-3/8") Pneumatic Pin Nailer, Air Duster

AF353



Capacity	Length: 15 - 35 mm (5/8 - 1-3/8") Gauge: 23 Ga
Magazine capacity	130
Operating pressure	0.45 - 0.69 MPa (65 - 100 PSI)
Dimensions (L x W x H)	208 x 66 x 191 mm (8-3/16 x 2-5/8 x 7-1/2")
Net weight	0.9 kg (2 lbs.)



25 mm (1") Pin Nailer

AF201Z



Capacity	Length: 12 - 25 mm (15/32 - 1")
Magazine capacity	100
Operating pressure	0.44 - 0.86 MPa (65 - 125 PSI)
Dimensions (L x W x H)	240 x 45 x 170 mm (9-1/2 x 1-3/4 x 6-3/4")
Net weight	0.9 kg (2 lbs.)



16 Ga 25 mm (1") Wide Crown Stapler

AT2550A



Capacity	Length: 25 - 50 mm (1 - 2") Width: 25 mm (1") Gauge: 16 Ga
Operating pressure	0.44 - 0.83 MPa (65 - 120 PSI)
Magazine capacity	140
Dimensions (L x W x H)	370 x 76 x 260 mm (14-1/2 x 3 x 10-1/4")
Net weight	2.3 kg (5.1 lbs.)



16 Ga 11 mm (7/16") Medium Crown Stapler

AT1150A



Capacity	Length: 25 - 50 mm (1 - 2") Width: 11 mm (7/16") Gauge: 16 Ga
Operating pressure	0.44 - 0.83 MPa (65 - 120 PSI)
Magazine capacity	140
Dimensions (L x W x H)	370 x 87 x 290 mm (14-1/2 x 3-7/16 x 11-3/8")
Net weight	2.3 kg (5.1 lbs.)



18V LXT BL Cordless 18 Ga 38mm (1-1/2") Narrow Crown Stapler

DST630

18V

new



Nail capacity	Gauge: 18 Ga Length: 9.5 - 38 mm (3/8 - 1-1/2") Outer width: 5.7 - 6.35 mm (7/32 - 1/4")
Magazine capacity	110 staples
Approx. work volume on a full battery charge (Battery)	1,800 shots BL1820B
Dimensions (L x W x H)	246 x 96 x 282 mm (9-11/16 x 3-3/4 x 11-1/8")
Net weight	2.8 - 3.1 kg (6.2 - 6.8 lbs.)



18 GA 38 mm (1-1/2") Narrow Crown Stapler, Air Duster

AT638A



Capacity	Length: 13 - 38 mm (1/2 - 1-1/2") Gauge: 18 Ga Width: 5.7 mm
Operating pressure	0.49 - 0.83 MPa (70 - 120 PSI)
Magazine capacity	100
Dimensions (L x W x H)	230 x 75 x 251 mm (9 x 2-15/16 x 9-7/8")
Net weight	1.2 kg (2.7 lbs.)



18 GA 38 mm (1-1/2") Narrow Crown Stapler

AT638



Capacity	Length: 15 - 38 mm (5/8 - 1-1/2") Gauge: 18 Ga Width: 5.7 mm
Operating pressure	0.39 - 0.78 MPa (60 - 115 PSI)
Magazine capacity	100
Dimensions (L x W x H)	247 x 62 x 246 mm (9-3/4 x 2-7/16 x 9-11/16")
Net weight	1.2 kg (2.7 lbs.)



18V LXT Li-Ion Cordless 10 mm (3/8") Stapler

DST221

18V



Staple	Width: 10 mm (3/8") Length: 10, 13, 16, 19, 22 mm (3/8, 1/2, 5/8, 3/4, 7/8") Gauge: 0.6 x 1.2 mm (1/32 x 1/16")
Magazine capacity	98
Dimensions (L x W x H)	251 x 91 x 212 mm (9-7/8 x 3-5/8 x 8-3/8")
Net weight	2.1 - 2.4 kg (4.7 - 5.3 lbs.)



18V LXT Li-Ion Cordless 10 mm (3/8") RT Stapler

DST112

18V



Staple	Width: 10 mm (3/8") Length: 7 - 10 mm (9/32 - 3/8")
Magazine capacity	150 (max 160)
Shot q'ty on a single full battery charge	w/ BL1830B: 6,000
Dimensions (L x W x H)	235 x 79 x 165 mm (9-1/4 x 3-1/8 x 6-1/2")
Net weight	1.5 - 1.8 kg (3.4 - 4 lbs.)



12V max CXT Li-Ion Cordless 10 mm (3/8") RT Stapler

ST113D

12V max



Staple	Width: 10 mm (3/8") Length: 7 - 10 mm (9/32 - 3/8")
Magazine capacity	150 (max 160)
Dimensions (L x W x H)	211 x 81 x 159 mm (8-5/16 x 3-3/16 x 6-1/4")
Net weight	1.3 kg (2.9 lbs.)



7.2 V Li-Ion Cordless 64 mm (2-1/2") Brad Nailer

GF600

7.2V



Nail capacity	Length: 15 - 64 mm (5/8 - 2-1/2") Gauge: 16 Ga
Magazine capacity	100 nails
Dimensions (L x W x H)	266 x 90 x 305 mm (10-1/2 x 3-1/2 x 12")
Net weight	2.2 kg (4.8 lbs.)



7.2 V Li-Ion Cordless 40 mm (1-9/16") Concrete Nailer

GN420C

7.2V



Capacity	Length: 15 - 40 mm (5/8 - 1-9/16") Dia.: 2.6 - 3.1 mm (0.102 - 0.122")
Magazine capacity	20
Dimensions (L x W x H)	315 x 108 x 390 mm (12-3/8 x 4-1/4 x 15-3/8")
Net weight	3.6 - 3.8 kg (7.9 - 8.3 lbs.)



Icon

- Double Insulation
- Variable Speed
- Reversing
- Anti-restart function
- Electronic 2-Speed
- Electronic 3-Speed
- Electronic 4-Speed
- Constant Speed
- Soft Start
- Stainless Tank
- Revolving Hose
- Static Free Hose
- Dust Collection
- Toolless blade change
- Built-in Job Light
- Carrying Case

40Vmax X2 (80Vmax) XGT BL AWS Cordless 40L Dust Class M GYUPPA Vacuum Cleaner (Wet & Dry)

VC006GM

40V max x2



Max sealed suction	18 kPa
Max air flow	at Hose end, w/ Hose 38-2.5: 3.7 m ³ /min
Tank capacity	Dry / Wet: 40 / 30 L
Continuous use	w/ BL4050F, at dial Min: 80 min. w/ BL4050F, at dial Max: 25 min.
Dimensions (L x W x H)	586 x 385 x 598 mm (23 x 15-1/8 x 23-1/2")
Net weight	18.4 - 20.8 kg (40.6 - 45.9 lbs.)



40Vmax X2 (80Vmax) XGT BL AWS Cordless 40L Dust Class L HEPA GYUPPA Vacuum Cleaner (Wet & Dry)

VC007GL

40V max x2



Max sealed suction	18 kPa
Max air flow	at Hose end, w/ Hose 38-2.5: 3.7 m ³ /min
Tank capacity	Dry / Wet: 40 / 30 L
Continuous use	w/ BL4050F, at dial Min: 80 min. w/ BL4050F, at dial Max: 25 min.
Dimensions (L x W x H)	586 x 385 x 598 mm (23 x 15-1/8 x 23-1/2")
Net weight	18.3 - 20.7 kg (40.3 - 45.6 lbs.)



40Vmax XGT BL AWS Cordless 15L Dust Class L HEPA GYUPPA Vacuum Cleaner (Dry Only)

VC004GL

40V max



Max sealed suction	23 kPa
Max air flow	at Hose end, w/ BL4050F, w/ ø28 x 3.5 m hose: 1.8 m ³ /min, at Turbine, w/ BL4050F: 4.2 m ³ /min
Tank capacity	Dry: 15 L
Continuous use	w/ BL4050F at Dial 1: 220 min. w/ BL4050F at Dial 5: 28 min.
Dimensions (L x W x H)	366 x 334 x 475 mm (14-3/8 x 13-1/8 x 18-3/4")
Net weight	8.6 - 11.7 kg (19.0 - 25.8 lbs.)



40Vmax XGT BL Cordless 15L Dust Class L Vacuum Cleaner (Wet & Dry)

VC003GL

40V max



Max sealed suction	23 kPa
Max air flow	at Hose end, w/ BL4050F, w/ ø38 x 2.5 m hose: 3.2 m ³ /min, at Hose end, w/ BL4050F, w/ ø32 x 1.7 m hose: 2.8 m ³ /min, at Turbine, w/ BL4050F: 4.2 m ³ /min
Tank capacity	Dry / Wet: 15 / 12 L
Continuous use	w/ BL4050F at Dial 1: 220 min. w/ BL4050F at Dial 5: 28 min.
Dimensions (L x W x H)	366 x 334 x 475 mm (14-3/8 x 13-1/8 x 18-3/4")
Net weight	8.4 - 11.5 kg (18.5 - 25.4 lbs.)



40Vmax XGT BL AWS Cordless 8L Dust Class L HEPA GYUPPA Vacuum Cleaner (Dry Only)

VC002GL

40V max



Max sealed suction	23 kPa
Max air flow	at Hose end, w/ BL4050F, w/ ø28 x 3.5 m hose: 1.8 m ³ /min, at Turbine, w/ BL4050F: 4.2 m ³ /min
Tank capacity	Dry: 8 L
Continuous use	w/ BL4050F at Dial 1: 220 min. w/ BL4050F at Dial 5: 28 min.
Dimensions (L x W x H)	366 x 334 x 425 mm (14-3/8 x 13-1/8 x 16-3/4")
Net weight	8.3 - 11.4 kg (18.3 - 25.1 lbs.)



40Vmax XGT BL Cordless 8L Dust Class L Vacuum Cleaner (Wet & Dry)

VC001GL

40V max



Max sealed suction	23 kPa
Max air flow	at Hose end, w/ BL4050F, w/ ø38 x 2.5 m hose: 3.2 m ³ /min, at Hose end, w/ BL4050F, w/ ø32 x 1.7 m hose: 2.8 m ³ /min, at Turbine, w/ BL4050F: 4.2 m ³ /min
Tank capacity	Dry / Wet: 8 / 6 L
Continuous use	w/ BL4050F at Dial 1: 220 min. w/ BL4050F at Dial 5: 28 min.
Dimensions (L x W x H)	366 x 334 x 425 mm (14-3/8 x 13-1/8 x 16-3/4")
Net weight	8.1 - 11.2 kg (17.9 - 24.7 lbs.)



40Vmax XGT BL Cordless 8L Dust Class L Vacuum Cleaner (Dry Only)

VC005GL

40V max



Max sealed suction	23 kPa
Max air flow	at Hose end, w/ BL4050F, w/ ø32 x 1.7 m hose: 2.8 m ³ /min, at Turbine, w/ BL4050F: 4.2 m ³ /min
Tank capacity	Dry: 8 L
Continuous use	w/ BL4050F at Dial 1: 220 min. w/ BL4050F at Dial 5: 28 min.
Dimensions (L x W x H)	366 x 334 x 397 mm (14-3/8 x 13-1/8 x 15-5/8")
Net weight	7.9 - 11.0 kg (17.4 - 24.3 lbs.)



18V X2 (36V) LXT BL AWS Cordless 15 L Dust Class L HEPA Vacuum Cleaner (Airborne Particles)

DVC157L

18V x2



Max sealed suction	11 kPa
Max air flow	at Hose end, at dial 1, w/ ø28 x 3.5 m hose: 1.1 m ³ /min, at Hose end, at dial 5, w/ ø28 x 3.5 m hose: 1.4 m ³ /min, at Turbine: 3.4 m ³ /min
Tank capacity	Dry: 15 L
Continuous use	w/ BL1860B: 100 min.
Dimensions (L x W x H)	366 x 334 x 421 mm (14-3/8 x 13-1/8 x 16-1/2")
Net weight	8.0 - 8.6 kg (17.6 - 19.0 lbs.)



18V X2 (36V) LXT BL Cordless 15 L Dust Class L Vacuum Cleaner (Dry Only)

DVC156L

18V x2



Max sealed suction	11 kPa
Max air flow	at Hose end, at dial 1, w/ ø28 x 3.5 m hose: 1.0 m ³ /min, at Hose end, at dial 5, w/ ø28 x 3.5 m hose: 1.4 m ³ /min, at Turbine: 3.4 m ³ /min
Tank capacity	Dry: 15 L
Continuous use	w/ BL1860B: 100 min.
Dimensions (L x W x H)	366 x 334 x 421 mm (14-3/8 x 13-1/8 x 16-1/2")
Net weight	7.3 - 7.9 kg (16.1 - 17.4 lbs.)

LXT BL MOTOR XPT



18V X2 (36V) LXT BL Cordless 15 L Dust Class L Vacuum Cleaner (Wet & Dry)

DVC155L

18V x2



Max sealed suction	11 kPa
Max air flow	at Hose end, at dial 1, w/ ø32 x 1.7 m hose: 1.5 m ³ /min, at Hose end, at dial 5, w/ ø32 x 1.7 m hose: 2.1 m ³ /min, at Turbine: 3.4 m ³ /min
Tank capacity	Dry / Wet: 15 / 12 L
Continuous use	w/ BL1860B: 100 min.
Dimensions (L x W x H)	366 x 334 x 421 mm (14-3/8 x 13-1/8 x 16-1/2")
Net weight	7.2 - 7.9 kg (15.9 - 17.4 lbs.)

LXT BL MOTOR XPT



18V X2 (36V) LXT BL AWS Cordless 8 L Dust Class L HEPA Vacuum Cleaner (Airborne Particles)

DVC867L

18V x2



Max sealed suction	11 kPa
Max air flow	at Hose end, at dial 1, w/ ø28 x 3.5 m hose: 1.1 m ³ /min, at Hose end, at dial 5, w/ ø28 x 3.5 m hose: 1.4 m ³ /min, at Turbine: 3.4 m ³ /min
Tank capacity	Dry: 8 L
Continuous use	w/ BL1860B: 100 min.
Dimensions (L x W x H)	366 x 334 x 368 mm (14-3/8 x 13-1/8 x 14-1/2")
Net weight	7.7 - 8.4 kg (17.0 - 18.5 lbs.)

LXT BL MOTOR AWS XPT HEPA Filter



18V X2 (36V) LXT BL Cordless 8 L Dust Class L Vacuum Cleaner (Dry Only)

DVC866L

18V x2



Max sealed suction	11 kPa
Max air flow	at Hose end, at dial 1, w/ ø32 x 1.7 m hose: 1.5 m ³ /min, at Hose end, at dial 5, w/ ø32 x 1.7 m hose: 2.1 m ³ /min, at Turbine: 3.4 m ³ /min
Tank capacity	Dry: 8 L
Continuous use	w/ BL1860B: 100 min.
Dimensions (L x W x H)	366 x 334 x 368 mm (14-3/8 x 13-1/8 x 14-1/2")
Net weight	7.0 - 7.7 kg (15.4 - 17.0 lbs.)

LXT BL MOTOR XPT



18V X2 (36V) LXT BL Cordless 8 L Dust Class L Vacuum Cleaner (Wet & Dry)

DVC865L

18V x2



Max sealed suction	11 kPa
Max air flow	at Hose end, at dial 1, w/ ø32 x 1.7 m hose: 1.5 m ³ /min, at Hose end, at dial 5, w/ ø32 x 1.7 m hose: 2.1 m ³ /min, at Turbine: 3.4 m ³ /min
Tank capacity	Dry / Wet: 8 / 6 L
Continuous use	w/ BL1860B: 100 min.
Dimensions (L x W x H)	366 x 334 x 368 mm (14-3/8 x 13-1/8 x 14-1/2")
Net weight	7.0 - 7.7 kg (15.4 - 17.0 lbs.)

LXT BL MOTOR XPT



Corded / 18V X2 (36V) LXT Li-Ion Cordless 8 L Dust Class L HEPA GYUPPA Vacuum Cleaner (Dry Only)

DVC861L

18V x2



Max sealed suction	AC / DC: 24 / 9 kPa
Max air flow	AC / DC: 3.6 / 2.1 m ³ /min
Capacity	Dry: 8 L
Continuous use	w/ BL1850B x2: 65 min.
Dimensions (L x W x H)	366 x 334 x 368 mm (14-3/8 x 13-1/8 x 14-1/2")
Net weight	9.3 - 9.9 kg (20.5 - 21.8 lbs.)

LXT DC Li-Ion HEPA GYUPPA!



Corded / 18V X2 (36V) LXT Li-Ion Cordless 8 L Dust Class L Vacuum Cleaner (Wet & Dry)

DVC860L

18V x2



Max sealed suction	AC / DC: 24 / 9 kPa
Max air flow	AC / DC: 3.6 / 2.1 m ³ /min
Capacity	Dry / Wet: 8 / 6 L
Continuous use	w/ BL1850B x2: 65 min.
Dimensions (L x W x H)	366 x 334 x 368 mm (14-3/8 x 13-1/8 x 14-1/2")
Net weight	8.6 - 9.2 kg (19 - 20.3 lbs.)

LXT DC Li-Ion



32 L Dust Class H GYUPPA Vacuum Cleaner (Wet & Dry)

VC3211H



Continuous rating Input	1,050W
Max sealed suction (water column)	22.0 kPa (2,240 mmH ₂ O)
Max peak air flow	2 m ³ /min
Tank capacity	Dry: 32 L Wet: 27 L
Dimensions (L x W x H)	552 x 398 x 685 mm (21-3/4 x 15-5/8 x 27")
Net weight	16.9 kg (37.3 lbs.)

GYUPPA! Twin Filter



32 L Dust Class M GYUPPA Vacuum Cleaner (Wet & Dry)

VC3211M



Continuous rating Input	1,050W
Max sealed suction (water column)	22.0 kPa (2,240 mmH ₂ O)
Max peak air flow	2.0 m ³ /min
Tank capacity	Dry: 32 L Wet: 27 L
Dimensions (L x W x H)	552 x 398 x 685 mm (21-3/4 x 15-5/8 x 27")
Net weight	16.9 kg (37.3 lbs.)

GYUPPA! Twin Filter



32 L Dust Class L GYUPPA Vacuum Cleaner (Wet & Dry)

VC3210L



Continuous rating Input	1,050W
Max sealed suction (water column)	22.0 kPa (2,240 mmH ₂ O)
Max peak air flow	2.0 m ³ /min
Tank capacity	Dry: 32 L Wet: 27 L
Dimensions (L x W x H)	552 x 398 x 685 mm (21-3/4 x 15-5/8 x 27")
Net weight	14.5 kg (32 lbs.)

GYUPPA!



Cleaning

22 L Dust Class M GYUPPA Vacuum Cleaner (Wet & Dry)

VC2201M

Continuous rating Input	1,050W
Max sealed suction (water column)	22.0 kPa (2,240 mmH ₂ O)
Max peak air flow	2.0 m ³ /min
Tank capacity	Dry: 22 L Wet: 17 L
Dimensions (L x W x H)	552 x 398 x 569 mm (21-3/4 x 15-5/8 x 22-3/8")
Net weight	16 kg (35.4 lbs.)



22 L Dust Class M GYUPPA Vacuum Cleaner (Wet & Dry)

VC2211M

Continuous rating Input	1,050W
Max sealed suction (water column)	22.0 kPa (2,240 mmH ₂ O)
Max peak air flow	2.0 m ³ /min
Tank capacity	Dry: 22 L Wet: 17 L
Dimensions (L x W x H)	552 x 398 x 569 mm (21-3/4 x 15-5/8 x 22-3/8")
Net weight	16.3 kg (35.9 lbs.)



25 L Dust Class L GYUPPA Vacuum Cleaner (Wet & Dry)

VC2510L

Continuous rating Input	1,050W
Max sealed suction (water column)	22.0 kPa (2,240 mmH ₂ O)
Max peak air flow	2.0 m ³ /min
Tank capacity	Dry: 25 L Wet: 14 L
Dimensions (L x W x H)	432 x 416 x 451 mm (17 x 16-3/8 x 17-3/4")
Net weight	10.5 kg (23.2 lbs.)



13 L Dust Class L GYUPPA Vacuum Cleaner (Wet & Dry)

VC1310L

Continuous rating Input	1,050W
Max sealed suction (water column)	22.0 kPa (2,240 mmH ₂ O)
Max peak air flow	2.0 m ³ /min
Tank capacity	Dry: 13 L Wet: 7 L
Dimensions (L x W x H)	366 x 334 x 420 mm (14-3/8 x 13-1/8 x 16-1/2")
Net weight	9.6 kg (21.2 lbs.)



34 L Dust Class M Vacuum Cleaner (Wet & Dry)

VC4210M

Continuous rating Input	1,200W
Max sealed suction	25.0 kPa
Max peak air flow	4.5 m ³ /min
Tank capacity	Dry: 34 L Wet: 30 L
Dimensions (L x W x H)	565 x 385 x 605 mm
Net weight	16 kg (35.3 lbs.)



34 L Dust Class L Vacuum Cleaner (Wet & Dry)

VC4210L

Continuous rating Input	1,200W
Max sealed suction	25.0 kPa
Max peak air flow	4.5 m ³ /min
Tank capacity	Dry: 34 L Wet: 30 L
Dimensions (L x W x H)	565 x 385 x 605 mm
Net weight	16 kg (35.3 lbs.)



24 L Dust Class M Vacuum Cleaner (Wet & Dry)

VC3012M

Continuous rating Input	1,500W
Max sealed suction	25.0 kPa
Max peak air flow	3.7 m ³ /min
Tank capacity	Dry: 24 L Wet: 19 L
Dimensions (L x W x H)	450 x 380 x 595 mm
Net weight	11 kg (25.3 lbs.)



24 L Dust Class L Vacuum Cleaner (Wet & Dry)

VC3012L

Continuous rating Input	1,500W
Max sealed suction	25.0 kPa
Max peak air flow	3.7 m ³ /min
Tank capacity	Dry: 24 L Wet: 19 L
Dimensions (L x W x H)	450 x 380 x 595 mm
Net weight	11 kg (25.3 lbs.)



26 L Dust Class L Vacuum Cleaner (Wet & Dry)

VC3011L

Continuous rating Input	1,000W
Max sealed suction	21.0 kPa
Max peak air flow	3.6 m ³ /min
Tank capacity	Dry: 26 L Wet: 23 L
Dimensions (L x W x H)	390 x 400 x 635 mm
Net weight	9 kg (19.9 lbs.)



21 L Dust Class L Vacuum Cleaner (Wet & Dry)

VC2512L

Continuous rating Input	1,000W
Max sealed suction	21.0 kPa
Max peak air flow	3.6 m ³ /min
Tank capacity	Dry: 21 L Wet: 18 L
Dimensions (L x W x H)	390 x 390 x 530 mm
Net weight	7 kg (15.5 lbs.)



15 L Dust Class L Vacuum Cleaner (Wet & Dry)

VC2012L

Continuous rating Input	1,000W
Max sealed suction	21.0 kPa
Max peak air flow	3.6 m ³ /min
Tank capacity	Dry: 15 L Wet: 12 L
Dimensions (L x W x H)	371 x 390 x 495 mm
Net weight	7 kg (15.5 lbs.)



20 L Dust Class L Vacuum Cleaner

VC2000L

Continuous rating Input	1,000W
Max sealed suction	21.0 kPa
Tank capacity	20 L
Dimensions (L x W x H)	390 x 385 x 505 mm
Net weight	7.5 kg



40Vmax XGT Brushless AWS Cordless 7.5 L Dust Class L HEPA Portable Vacuum Cleaner (Wet & Dry)

VC013GL

40V max

new



Max sealed suction	4.5 - 15 kPa
Air volume	1.0 - 2.0 m ³ /min
Turbine air volume	2.9 m ³ /min
Tank capacity	Dry / Wet: 7.5 / 4.5 L
Continuous use (Battery)	22 - 120 min. BL4050F
Dimensions (L x W x H)	400 x 251 x 282 mm (15-3/4 x 9-7/8 x 11-1/8")
Net weight	5.0 - 6.2 kg (11.0 - 13.7 lbs.)



40Vmax XGT Brushless Cordless 7.5 L Dust Class L HEPA Portable Vacuum Cleaner (Wet & Dry)

VC014GL

40V max

new



Max sealed suction	4.5 - 15 kPa
Air volume	1.0 - 2.0 m ³ /min
Turbine air volume	2.9 m ³ /min
Tank capacity	Dry / Wet: 7.5 / 4.5 L
Continuous use (Battery)	22 - 120 min. BL4050F
Dimensions (L x W x H)	400 x 251 x 282 mm (15-3/4 x 9-7/8 x 11-1/8")
Net weight	5.0 - 6.2 kg (11.0 - 13.7 lbs.)



18V LXT BL Brushless Cordless 7.5 L Dust Class L HEPA Portable 2-Speed Vacuum Cleaner (Wet & Dry)

DVC750L

18V



Max sealed suction	High / Normal: 6.7 / 4.2 kPa
Max air flow	at Hose end, High: 1.6 m ³ /min, at Hose end, Normal: 1.3 m ³ /min, at Turbine: 2.4 m ³ /min
Tank capacity	Dry / Wet: 7.5 / 4.5 L
Continuous use	w/ BL1850B, High: 30 min. w/ BL1850B, Normal: 60 min.
Dimensions (L x W x H)	418 x 251 x 278 mm (16-1/2 x 9-7/8 x 11")
Net weight	4.3 - 4.6 kg (9.4 - 10.1 lbs.)



18V LXT Li-Ion Cordless Vacuum Cleaner

DVC350

18V



Max sealed suction (water column)	6.0 kPa (612 mmH ₂ O)
Max air flow	3.4 m ³ /min
Continuous use	High: 13 min. Low: 26 min. BL1830
(Battery)	
Dimensions (L x W x H)	273 x 195 x 226 mm (10-3/4 x 7-5/8 x 8-7/8")
Net weight	2.2 kg (4.9 lbs.)



Cleaning

40Vmax XGT Brushless AWS Cordless HEPA Backpack Vacuum Cleaner

VC012G

40V max



Max sealed suction	20 kPa
Max air flow	2.1 m ³ /min
Capacity	Paper dust bag: 6.0 L Cloth dust bag: 5.5 L
Continuous use	w/ BL4050F x2, Mode 3: 40 min. w/ BL4050F x2, Mode 2: 75 min. w/ BL4050F x2, Mode 1: 130 min.
Dimensions (L x W x H)	w/ BL4040 x2: 301 x 185 x 526 mm (11-7/8 x 7-1/4 x 20-3/4")
Net weight	6.4 - 9.5 kg (14.1 - 20.9 lbs.)



40Vmax XGT Brushless Cordless HEPA Backpack Vacuum Cleaner

VC011G

40V max



Max sealed suction	20 kPa
Max air flow	2.4 m ³ /min
Capacity	Paper dust bag: 6.0 L Cloth dust bag: 5.5 L
Continuous use	w/ BL4050F x2, Mode 4: 40 min. w/ BL4050F x2, Mode 3: 75 min. w/ BL4050F x2, Mode 2: 130 min. w/ BL4050F x2, Mode 1: 260 min.
Dimensions (L x W x H)	w/ BL4040 x2: 301 x 185 x 526 mm (11-7/8 x 7-1/4 x 20-3/4")
Net weight	6.4 - 9.5 kg (14.1 - 20.9 lbs.)



40Vmax XGT BL AWS Cordless HEPA Backpack Vacuum Cleaner

VC009G

40V max



Max sealed suction	18 kPa
Max air flow	1.9 m ³ /min
Capacity	Paper dust bag: 2.0 L Cloth dust bag: 1.5 L
Continuous use	w/ BL4050F, Mode 3: 14 min. w/ BL4050F, Mode 2: 30 min. w/ BL4050F, Mode 1: 55 min.
Dimensions (L x W x H)	w/ BL4080F: 233 x 158 x 413 mm (9-1/8 x 6-1/4 x 16-1/4")
Net weight	4.1 - 5.3 kg (9.0 - 11.7 lbs.)



40Vmax XGT BL Brushless Cordless HEPA Backpack Vacuum Cleaner

VC008G

40V max



Max sealed suction	18 kPa
Max air flow	2.4 m ³ /min
Capacity	Paper dust bag: 2.0 L Cloth dust bag: 1.5 L
Continuous use	w/ BL4050F, Mode 4: 14 min. w/ BL4050F, Mode 3: 30 min. w/ BL4050F, Mode 2: 55 min. w/ BL4050F, Mode 1: 110 min.
Dimensions (L x W x H)	w/ BL4080F: 233 x 158 x 413 mm (9-1/8 x 6-1/4 x 16-1/4")
Net weight	4.1 - 5.3 kg (9.0 - 11.7 lbs.)



18V X2 (36V) LXT BL AWS Cordless HEPA Backpack Vacuum Cleaner

DVC665

18V x2



Max sealed suction	11 kPa
Max air flow	w/ Hose 28-1.5: 1.8 m ³ /min
Capacity	Paper dust bag: 6 L Cloth dust bag: 5.5 L
Continuous use	w/ BL1860B, Max: 40 min. w/ BL1860B, High: 75 min. w/ BL1860B, Normal: 140 min.
Dimensions (L x W x H)	297 x 174 x 523 mm (11-3/4 x 6-7/8 x 20-5/8")
Net weight	6.1 - 6.7 kg (13.5 - 14.9 lbs.)



18V X2 (36V) LXT BL Brushless Cordless HEPA Backpack Vacuum Cleaner

DVC660

18V x2



Max sealed suction	11 kPa
Max air flow	w/ Hose 38-1.5: 2.3 m ³ /min w/ Hose 28-1.0: 2.0 m ³ /min w/ Hose 28-1.5: 1.8 m ³ /min
Capacity	Paper dust bag: 6 L Cloth dust bag: 5.5 L
Continuous use	w/ BL1860B, Max: 40 min. w/ BL1860B, High: 75 min. w/ BL1860B, Normal: 140 min.
Dimensions (L x W x H)	297 x 174 x 523 mm (11-3/4 x 6-7/8 x 20-5/8")
Net weight	6.1 - 6.7 kg (13.4 - 14.8 lbs.)



18V X2 (36V) LXT BL AWS Cordless HEPA Backpack Vacuum Cleaner

DVC265

18V x2



Max sealed suction	11 kPa
Max air flow	w/ Hose 28-1.0: 2 m ³ /min w/ Hose 28-1.5: 1.8 m ³ /min
Capacity	Paper dust bag: 2 L Cloth dust bag: 1.5 L
Continuous use	w/ BL1860B, High: 40 min. w/ BL1860B, Low: 75 min.
Dimensions (L x W x H)	230 x 152 x 373 mm (9 x 6 x 14-3/4")
Net weight	3.9 - 4.5 kg (8.6 - 10.0 lbs.)



18V X2 (36V) LXT BL Brushless Cordless HEPA Backpack Vacuum Cleaner

DVC261

18V x2



Max sealed suction	11 kPa
Max air flow	w/ Hose 38-1.5: 2.3 m ³ /min w/ Hose 28-1.0: 2.0 m ³ /min w/ Hose 28-1.5: 1.8 m ³ /min
Capacity	Paper dust bag: 2.0 L Cloth dust bag: 1.5 L
Continuous use	w/ BL1860B, Max: 40 min. w/ BL1860B, High: 75 min. w/ BL1860B, Normal: 140 min.
Dimensions (L x W x H)	230 x 152 x 373 mm (9 x 6 x 14-3/4")
Net weight	3.8 - 4.5 kg (8.5 - 9.9 lbs.)



Model No.	Dust class	Powered	Tank capacity Dry / Wet (L)	Tank type	Max Air Flow (m ³ / min)	Max Sealed Suction (kPa)	Switch of connected power tool
-----------	------------	---------	-----------------------------	-----------	-------------------------------------	--------------------------	--------------------------------

Cordless Vacuum Cleaner / Vacuum Cleaner

VC006GM	M	DC (40Vmax x2)	40 / 30	Plastic	3.7 (hose Ø 38-2.5)	18	AWS
VC007GL	L (HEPA filter)	DC (40Vmax x2)	40 / 30	Plastic	3.7 (hose Ø 38-2.5)	18	AWS
VC005GL	L	DC (40Vmax)	8 / -	Plastic	2.8 (hose Ø 32-1.7)	23	-
VC004GL	L (HEPA filter)	DC (40Vmax)	15 / -	Plastic	1.8 (hose Ø 28-3.5)	23	AWS
VC003GL	L	DC (40Vmax)	15 / 12	Plastic	3.2 (hose Ø 38-2.5)	23	-
VC002GL	L (HEPA filter)	DC (40Vmax)	8 / -	Plastic	1.8 (hose Ø 28-3.5)	23	AWS
VC001GL	L	DC (40Vmax)	8 / 6	Plastic	3.2 (hose Ø 38-2.5)	23	-
DVC157L	L (HEPA filter)	DC (LXT18V x2)	15 / -	Plastic	2.4 (hose Ø 38-2.5)	11	AWS
DVC156L	L	DC (LXT18V x2)	15 / -	Plastic	2.1 (hose Ø 32-1.7)	11	-
DVC155L	L	DC (LXT18V x2)	15 / 12	Plastic	2.1 (hose Ø 32-1.7)	11	-
DVC867L	L (HEPA filter)	DC (LXT18V x2)	8 / -	Plastic	2.4 (hose Ø 38-2.5)	11	AWS
DVC866L	L	DC (LXT18V x2)	8 / -	Plastic	2.1 (hose Ø 32-1.7)	11	-
DVC865L	L	DC (LXT18V x2)	8 / 6	Plastic	2.1 (hose Ø 32-1.7)	11	-
DVC861L	L (HEPA filter)	DC (LXT18V x2) / AC	8 / -	Plastic	AC/DC : 3.6 / 2.1 (Ø 38-2.5)	AC/DC : 24 / 9.0	-
DVC860L	L	DC (LXT18V x2) / AC	8 / 6	Plastic	AC/DC : 3.6 / 2.1 (Ø 38-2.5)	AC/DC : 24 / 9.0	-
VC3211H	H	AC	32 / 27	Stainless steel	2.0 (hose Ø 28-3.5)	22	Automatic
VC3211M	M	AC	32 / 27	Stainless steel	2.0 (hose Ø 28-3.5)	22	Automatic
VC3210L	L	AC	32 / 27	Stainless steel	2.0 (hose Ø 28-3.5)	22	Automatic
VC2201M	M	AC	22 / 17	Stainless steel	2.0 (hose Ø 28-3.5)	22	-
VC2211M	M	AC	22 / 17	Stainless steel	2.0 (hose Ø 28-3.5)	22	Automatic
VC2510L	L	AC	25 / 14	Plastic	2.0 (hose Ø 28-3.5)	22	Automatic
VC1310L	L	AC	13 / 7	Plastic	2.0 (hose Ø 28-3.5)	22	Automatic
VC4210M	M	AC	34 / 30	Plastic	4.5	25	Automatic
VC4210L	L	AC	34 / 30	Plastic	4.5	25	Automatic
VC3012M	M	AC	24 / 19	Plastic	3.7	25	Automatic
VC3012L	L	AC	24 / 19	Plastic	3.7	25	Automatic
VC3011L	L	AC	26 / 23	Stainless steel	3.6	21	Automatic
VC2512L	L	AC	21 / 18	Plastic	3.6	21	Automatic
VC2012L	L	AC	15 / 12	Stainless steel	3.6	21	Automatic
VC2000L	L	AC	20 / -	Plastic	-	21	-
DVC350	-	DC (LXT18V)	3 / -	-	3.4	6	-
VC013GL	L (HEPA filter)	DC (40Vmax)	7.5 / 4.5	Plastic	2.0	15	AWS
VC014GL	L (HEPA filter)	DC (40Vmax)	7.5 / 4.5	Plastic	2.0	15	-
DVC750L	L (HEPA filter)	DC (LXT18V)	7.5 / 4.5	Plastic	1.6	6.7	-

Cordless Backpack Vacuum Cleaner

VC012G	(HEPA filter)	DC (40Vmax)	Paper dust bag 6.0 / - Cloth dust bag 5.5	-	2.1	20	AWS
VC011G	(HEPA filter)	DC (40Vmax)	Paper Dust bag 6.0 / - Cloth Dust bag 5.5	-	2.4	20	-
VC009G	(HEPA filter)	DC (40Vmax)	Paper dust bag: 2.0 / - Cloth Dust Bag 1.5	-	1.9 (hose Ø 28-1.5)	18	AWS
VC008G	(HEPA filter)	DC (40Vmax)	Paper dust bag: 2.0 / - Cloth Dust Bag 1.5	-	2.4 (hose Ø 32-1.0)	18	-
DVC665	(HEPA filter)	DC (LXT18V x2)	Paper dust bag 6.0 / - Cloth dust bag 5.5	-	1.8 (hose Ø 28-1.5)	11	AWS
DVC660	(HEPA filter)	DC (LXT18V x2)	Paper dust bag 6.0 / - Cloth dust bag 5.5	-	2.2 (hose Ø 32-1.0)	11	-
DVC265	(HEPA filter)	DC (LXT18V x2)	Paper dust bag 2.0 / - Cloth dust bag 1.5	-	2.0 (hose Ø 28-1.0)	11	AWS
DVC261	(HEPA filter)	DC (LXT18V x2)	Paper dust bag 2.0 / - Cloth dust bag 1.5	-	2.2 (hose Ø 32-1.0)	11	-

Cordless Upright Cleaner

VC010G	L(HEPA filter)	DC (40Vmax)	5 / -	-	1.8	15	-
DVC560	L(HEPA filter)	DC (LXT18V x2)	5 / -	-	1.9	12	-

Cleaning

18V LXT BL Brushless Cordless HEPA 2-Speed Cyclone Cleaner

DCL501

18V



Max sealed suction (water column)	10 kPa (1,020 mmH ₂ O)
Max air flow	1.2 m ³ /min
Capacity	250 mL
Continuous use	w/ BL1860B (High): 35 min. w/ BL1860B (Low): 77 min.
Dimensions (L x W x H)	352 x 189 x 252 mm (13-7/8 x 7-7/16 x 9-7/8")
Net weight	3.1 - 3.4 kg (6.8 - 7.5 lbs.)



18V LXT BL Brushless HEPA Robotic Cleaner w/ Mapping Function

DRC300

18V



Max cleaning area	w/ BL1860B x2: 600 m ²
Continuous use	w/ BL1860B x2: 240 min.
Max registrable mapping area	10,000 m ²
Rotation speed	Main brush: 1,600 min ⁻¹ Side brush: 200 min ⁻¹
Max running speed	0.3 m/sec
Dust box capacity	3.0 L
Dimensions (L x W x H)	500 x 500 x 204 mm (19-3/4 x 19-3/4 x 8")
Net weight	9.6 - 10.6 kg (21.2 - 23.4 lbs.)



18 V LXT BL Brushless Robotic Cleaner

DRC200

18V



Max cleaning area	w/ BL1850B x2: 500 m ²
Continuous use	w/ BL1850B x2: 200 min.
Max running speed	0.3 m/sec
Dust box capacity	2.5 L
Dimensions (L x W x H)	460 x 460 x 180 mm (18-1/8 x 18-1/8 x 7-1/8")
Net weight	7.8 kg (16.1 lbs.)



40Vmax XGT Brushless Cordless 5 L HEPA Upright Cleaner

VC010G

40V max



Max sealed suction	15 kPa
Max air flow	1.8 m ³ /min
Capacity	5.0 L (1.3 gal)
Cleaning width	381 mm (15")
Continuous use	w/ BL4050F, High / Normal / Low noise: 25 / 50 / 100 min.
Dimensions (L x W x H)	326 x 381 x 1,146 mm (12-7/8 x 15 x 45")
Net weight	8.0 - 9.2 kg (17.6 - 20.3 lbs.)



18V X2 (36V) LXT BL Brushless Cordless 5 L HEPA Upright Cleaner

DVC560

18V x2



Max sealed suction	12 kPa
Max air flow	1.9 m ³ /min
Capacity	Dust: 5 L
Cleaning width	318 mm (12-1/2")
Continuous use	w/ BL1860B x2 High / Normal / Low noise: 30 / 60 / 120 min.
Dimensions (L x W x H)	326 x 318 x 1,146 mm (12-7/8 x 12-1/2 x 45")
Net weight	8.3 - 9.0 kg (18.3 - 19.8 lbs.)



18V LXT Li-Ion Cordless 3-Speed Cleaner

DCL184

18V



Max sealed suction	5.4 kPa (550 mmH ₂ O)
Max air flow	Cleaning: 1.4 m ³ /min Blowing: 0.4 m ³ /min
Max air velocity	Blowing: 100 m/s
Continuous use	Max / High / Normal: 20 / 30 / 80 min.
(Battery)	BL1830B
Dimensions (L x W x H)	w/ BL1830B / BL1840B / BL1850B / BL1860B: 365 x 138 x 202 mm (14-3/8 x 5-7/16 x 8")
Net weight	1.8 - 2.2 kg (4.0 - 4.9 lbs.)



12Vmax CXT Li-Ion Cordless 3-Speed Cleaner

CL121D

12V max



Max sealed suction	4.6 kPa (470 mmH ₂ O)
Max air flow	Cleaning: 1.3 m ³ /min Blowing: 0.3 m ³ /min
Max air velocity	Blowing: 76 m/s
Continuous use	w/ BL1041B, Max / High / Normal: 27 / 32 / 67 min.
Dimensions (L x W x H)	w/ BL1041B: 359 x 138 x 202 mm (14-1/8 x 5-7/16 x 8")
Net weight	1.7 - 1.8 kg (3.7 - 4.0 lbs.)



40Vmax XGT BL Cordless 24 L Dust Class HEPA Vacuum Sweeper

VS001G

40V max



Cleaning width	Main brush: 480 mm (18-7/8") Side brush: 650 mm (25-1/2")
Dust container capacity	24 L (6.3 gal)
Dust collection volume	15.6 L (4.1 gal)
Dust bag capacity (Optional accessory)	47 L (12.4 gal)
Continuous use	Quiet: 290, 480 min./ Standard: 120, 200 min.
(Battery)	BL4050F x2, BL4080F x2
Dimensions (L x W x H)	w/ Handle in upright position: 830 x 677 x 1,146 mm (32-3/4 x 26-3/4 x 45")
Net weight	29.9 - 33.1 kg (65.9 - 73.0 lbs.)



40V max
XGT

CL001G / CL002G / CL003G / CL004G



	CL001G	CL002G	CL003G	CL004G
Max sealed suction	21 kPa (2,100 mmH ₂ O)	21 kPa (2,100 mmH ₂ O)	20 kPa (2,000 mmH ₂ O)	20 kPa (2,041 mmH ₂ O)
Max air flow	1.2 m ³ /min	1.2 m ³ /min	1.0 m ³ /min	1.0 m ³ /min
Dust capacity	730 mL (24.7 oz)	Cloth dust bag: 500 mL Paper dust bag: 330 mL	250 mL (8.5 oz)	250 mL (8.5 oz)
Continuous use	w/ BL4025, Mode 1 / 2 / 3 / 4: 80 / 40 / 25 / 16 min.	w/ BL4025, Mode 1 / 2 / 3 / 4: 80 / 40 / 25 / 16 min.	w/ BL4025, Mode 1 / 2 / 3 / 4: 80 / 40 / 25 / 16 min.	w/ BL4025, Mode 1 / 2 / 3 / 4: 60 / 40 / 20 / 14 min.
Dimensions (L x W x H)	w/ BL4025: 1,066 x 113 x 152 mm (42 x 4-7/16 x 6")	w/ BL4025: 1,066 x 114 x 152 mm (42 x 4-1/2 x 6")	w/ BL4025: 1,106 x 113 x 177 mm (43-1/2 x 4-7/16 x 7")	w/ BL4025: 1,094 x 243 x 186 mm (43 x 9-9/16 x 7-3/8")
Net weight	1.7 - 2.3 kg (3.7 - 5.1 lbs.)	1.8 - 3.0 kg (4.0 - 6.6 lbs.)	1.9 - 2.5 kg (4.2 - 5.5 lbs.)	2.2 - 2.8 kg (4.9 - 6.2 lbs.)

18V
LXT
Fast Charging

DCL283F / DCL284F / DCL285F / DCL286F



	DCL283F	DCL284F	DCL285F	DCL286F
Max sealed suction	17.5 kPa (1,785 mmH ₂ O)	18 kPa (1,836 mmH ₂ O)	18 kPa (1,836 mmH ₂ O)	18 kPa (1,836 mmH ₂ O)
Max air flow	1.1 m ³ /min	1.2 m ³ /min	1.2 m ³ /min	1.0 m ³ /min
Capacity	730 mL (24.7 oz)	730 mL (24.7 oz)	Cloth dust bag: 500 mL Paper dust bag: 330 mL	250 mL (8.5 oz)
Continuous use	w/ BL1830B: 10 min.	w/ BL1830B, Mode 1 / 2 / 3 / 4: 38 / 21 / 15 / 8 min.	w/ BL1830B, Mode 1 / 2 / 3 / 4: 38 / 21 / 15 / 8 min.	w/ BL1830B, Mode 1 / 2 / 3 / 4: 38 / 21 / 15 / 8 min.
Dimensions (L x W x H)	w/ BL1850B: 503 x 113 x 155 mm (19-3/4 x 4-7/16 x 6-1/8")	w/ BL1850B: 503 x 113 x 153 mm (19-3/4 x 4-7/16 x 6")	w/ BL1850B: 503 x 113 x 153 mm (19-3/4 x 4-7/16 x 6")	w/ BL1850B: 543 x 113 x 177 mm (21-3/8 x 4-7/16 x 7")
Net weight	1.3 - 1.6 kg (2.9 - 3.5 lbs.)	1.3 - 1.6 kg (2.9 - 3.5 lbs.)	1.4 - 1.7 kg (3.1 - 3.7 lbs.)	1.6 - 1.9 kg (3.5 - 4.2 lbs.)

DCL180 / DCL181F / DCL182



	DCL180	DCL181F	DCL182
Max sealed suction	4.2 kPa (428 mmH ₂ O)	5.3 kPa (540 mmH ₂ O)	4.0 kPa (400 mmH ₂ O)
Max air flow	1.4 m ³ /min	1.4 m ³ /min	1.0 m ³ /min
Capacity	650 mL	650 mL	Cloth dust bag: 500 mL Paper dust bag: 330 mL
Continuous use	w/ BL1830B: 20 min.	w/ BL1830B, High / Low: 20 / 40 min.	w/ BL1830B, High / Low: 20 / 40 min.
Dimensions (L x W x H)	999 x 114 x 152 mm (39-1/4 x 4-1/2 x 6")	999 x 114 x 152 mm (39-1/4 x 4-1/2 x 6")	1,004 x 115 x 151 mm (39-1/2 x 4-1/2 x 5-15/16")
Net weight	1.2 kg (2.7 lbs.)	1.2 - 1.4 kg (2.7 - 3.1 lbs.)	1.3 kg (2.9 lbs.)

12V max
CXT
Fast Charging

CL106FD / CL107FD / CL108FD / CL200FD



	CL106FD	CL107FD	CL108FD	CL200FD
Max sealed suction	3.1 kPa (316 mmH ₂ O)	5.0 kPa (510 mmH ₂ O)	4.4 kPa (445 mmH ₂ O)	14 kPa
Max air flow	1.3 m ³ /min	1.4 m ³ /min	1.2 m ³ /min	0.8 m ³ /min
Capacity	600 mL	Cloth dust bag: 500 mL Paper dust bag: 330 mL	600 mL	250 mL (8.5 oz)
Continuous use	w/ BL1041B: 42 min.	w/ BL1041B, Max / High / Normal: 20 / 24 / 50 min.	w/ BL1016, Max / High / Normal: 10 / 12 / 25 min.	w/ BL1050, Powerful / High / Normal: 20 / 40 / 66 min.
Dimensions (L x W x H)	958 x 100 x 150 mm (37-3/4 x 4-1/2 x 5-7/8")	960 x 112 x 150 mm (37-3/4 x 4-3/8 x 5-7/8")	956 x 110 x 150 mm (37-5/8 x 4-5/16 x 5-7/8")	1,037 x 91 x 151 mm (40-3/4 x 3-5/8 x 5-15/16")
Net weight	1 - 1.1 kg (2.1 - 2.5 lbs.)	1.1 - 1.3 kg (2.5 - 2.9 lbs.)	1.0 - 1.2 kg (2.2 - 2.6 lbs.)	0.9 - 1.3 kg (2.0 - 2.9 lbs.)

12V max
Built-in Battery

CL114FD / CL117FD



	CL114FD	CL117FD
Max sealed suction	5.0 kPa (510 mmH ₂ O)	5.0 kPa (510 mmH ₂ O)
Max air flow	1.4 m ³ /min	1.0 m ³ /min
Capacity	Cloth dust bag: 500 mL Paper dust bag: 330 mL	650 mL
Continuous use	Powerful / High / Normal: 10 / 18 / 55 min.	Powerful / High / Normal: 10 / 18 / 55 min.
Dimensions (L x W x H)	983 x 113 x 136 mm (38-3/4 x 4-7/16 x 5-3/8")	992 x 110 x 136 mm (39 x 4-5/16 x 5-3/8")
Net weight	1.1 kg (2.4 lbs.)	1.0 kg (2.2 lbs.)

7.2V
10.8V

CL070D / CL072D / **CL100D / CL102D**



	CL070D	CL072D	CL100D	CL102D
Max sealed suction	2.2 kPa (224 mmH ₂ O)	2.1 kPa (214 mmH ₂ O)	2.3 kPa (235 mmH ₂ O)	2.7 kPa (275 mmH ₂ O)
Max air flow	1.2 m ³ /min	1.1 m ³ /min	1.3 m ³ /min	1.1 m ³ /min
Capacity	600 mL	Cloth dust bag: 500 mL Paper dust bag: 330 mL	600 mL	Cloth dust bag: 500 mL Paper dust bag: 330 mL
Continuous use	8 min.	High / Low: 8 / 16 min.	12 min.	High / Low: 13 / 21 min.
Dimensions (L x W x H)	966 x 103 x 142 mm (38-1/32 x 4-1/16 x 5-5/8")	984 x 113 x 146 mm (38-3/4 x 4-7/16 x 5-3/4")	966 x 103 x 150 mm (38-1/32 x 4-1/16 x 5-7/8")	984 x 113 x 150 mm (38-3/4 x 4-7/16 x 5-7/8")
Net weight	0.81 kg (1.8 lbs.)	1 kg (2.2 lbs.)	0.88 kg (1.94 lbs.)	1.1 kg (2.4 lbs.)

18V

CL183D



	CL183D
Max sealed suction	2.6 kPa (270 mmH ₂ O)
Max air flow	1.3 m ³ /min
Capacity	600 mL
Continuous use	w/ BL1815G: 30 min.
Dimensions (L x W x H)	966 x 102 x 148 mm (38 x 4 x 5-7/8")
Net weight	1.2 kg (2.6 lbs.)

Cleaning

Capsule type



One touch switch



CL001G **40Vmax**

Easy shake off dust filter

Max Air Flow **Max Sealed Suction**
1.2 m³/min **21 kPa**

DCL284F **18V**

Easy shake off dust filter

Max Air Flow **Max Sealed Suction**
1.2 m³/min **18 kPa**

DCL181F **18V**

Easy shake off dust filter

Max Air Flow **Max Sealed Suction**
1.4 m³/min **5.3 kPa**

Paper bag type



One touch switch



CL002G **40Vmax**

Easy shake off dust bag

Max Air Flow **Max Sealed Suction**
1.2 m³/min **21 kPa**

DCL285F **18V**

Easy shake off dust bag

Max Air Flow **Max Sealed Suction**
1.2 m³/min **18 kPa**

DCL182 **18V**

Easy shake off dust bag

Max Air Flow **Max Sealed Suction**
1.0 m³/min **4.0 kPa**

Capsule type



Trigger switch



DCL283F **18V**

Easy shake off dust filter

Lock on button

Max Air Flow **Max Sealed Suction**
1.1 m³/min **17.5 kPa**

DCL180 **18V**

Easy shake off dust filter

Max Air Flow **Max Sealed Suction**
1.4 m³/min **4.2 kPa**

CL106FD **12Vmax**

Max Air Flow **Max Sealed Suction**
1.3 m³/min **3.1 kPa**

Cyclone unit



One touch switch



CL004G **40Vmax**

High performance filter set

Electric rotary brush

Max Air Flow **Max Sealed Suction**
1.0 m³/min **20 kPa**

CL003G **40Vmax**

High performance filter set

Max Air Flow **Max Sealed Suction**
1.0 m³/min **20 kPa**

DCL286F **18V**

High performance filter set

Max Air Flow **Max Sealed Suction**
1.0 m³/min **18 kPa**

 **CL108FD** 12Vmax



Max Air Flow **Max Sealed Suction**
1.2 m³/min **4.4 kPa**

 **CL117FD 2.0Ah** 12Vmax
Built-in Battery



Max Air Flow **Max Sealed Suction**
1.0 m³/min **5.0 kPa**

 **Home**

 **Building**

 **Built-in Job Light**

 **Electronic 2-Speed**

 **Electronic 3-Speed**

 **Electronic 4-Speed**

 **Anti-restart function**

 **CL107FD** 12Vmax



Max Air Flow **Max Sealed Suction**
1.4 m³/min **5.0 kPa**

 **CL114FD 2.0Ah** 12Vmax
Built-in Battery



Max Air Flow **Max Sealed Suction**
1.4 m³/min **5.0 kPa**

 **CL102D** 10.8V





Max Air Flow **Max Sealed Suction**
1.1 m³/min **2.7 kPa**

 **CL072D** 7.2V





Max Air Flow **Max Sealed Suction**
1.1 m³/min **2.1 kPa**

 **CL100D** 10.8V



Max Air Flow **Max Sealed Suction**
1.3 m³/min **2.3 kPa**

 **CL070D** 7.2V



Max Air Flow **Max Sealed Suction**
1.2 m³/min **2.2 kPa**

 **CL183D** 18V



Max Air Flow **Max Sealed Suction**
1.3 m³/min **2.6 kPa**

 **CL200FD** 12Vmax



 High performance filter set



Max Air Flow **Max Sealed Suction**
0.8 m³/min **14 kPa**

Cleaning

BL Brushless Battery Powered Variable Speed Backpack Blower

UB004C



No load speed	Mode 1 / 2 / 3: 10,500 / 18,000 / 22,500 min ⁻¹ Boost mode: 23,800 min ⁻¹
Blowing force	w/ PDC1500, Mode 1 / 2 / 3: 5 / 15 / 25 N w/ PDC1500, Boost mode: 28 N
Air volume	w/ PDC1500, Mode 1 / 2 / 3: 8.5 / 15.2 / 19.7 m ³ /min w/ PDC1500, Boost mode: 20.9 m ³ /min
Max air velocity	w/ PDC1500, Mode 1 / 2 / 3: 33.2 / 59.0 / 76.3 m/s w/ PDC1500, Boost mode: 80.7 m/s
Continuous use	55 - 200 min.
Dimensions (L x W x H)	460 x 575 x 585 mm (18-1/8 x 22-5/8 x 23")
Net weight	16.5 - 18.6 kg (36.4 - 41.0 lbs.)



BL Brushless Battery Powered Variable Speed Blower

UB003C



No load speed	Mode 1 / Mode 2 / Mode 3: 4,000 - 10,600 / 17,700 / 22,100 min ⁻¹
Blowing force	w/ End nozzle, w/ PDC1500, Max speed mode: 24 N
Max air volume	w/ End nozzle, w/ PDC1500, Max speed mode: 17.6 m ³ /min
Max air velocity	w/ End nozzle, w/ PDC1500, Max speed mode: 86.0 m/s
Continuous use	w/ End nozzle, w/ PDC1500, Max speed mode: 60 min.
Dimensions (L x W x H)	w/ Nozzle: 913 - 1,013 x 178 x 298 mm (36 - 40 x 7 x 11-3/4")
Net weight	2.8 - 3.1 kg (6.2 - 6.8 lbs.)



40Vmax XGT BL Brushless Cordless Variable Speed Blower

UB001G

40V max



No load speed	Cruise control mode: 0 - 20,000 min ⁻¹ Boost mode: 23,000 min ⁻¹
Blowing force	Cruise control mode: 0 - 12 N Boost mode: 17 N
Max air volume	Cruise control mode: 0 - 13.5 m ³ /min Boost mode: 16.0 m ³ /min
Max air velocity	Cruise control mode: 53 m/s Boost mode: 64 m/s
Continuous use	Cruise control mode, w/ BL4050F: 15 min. Boost mode, w/ BL4050F: 8 min.
Dimensions (L x W x H)	w/ End nozzle 80, w/ BL4050F: 943 - 1,043 x 167 x 297 mm (37-1/8 - 41 x 6-9/16 x 11-3/4")
Net weight	3.1 - 3.9 kg (6.8 - 8.6 lbs.)



40Vmax XGT Brushless Cordless Variable Speed Blower

UB003G

40V max



Blower function	Max blowing force: 7_16N Max air volume: 9.4_13.8 m ³ /min (332_487 CFM) Max air velocity: 0_46.68 m/s (0_103_152 MPH) Continuous use: 30_9 min
(Battery)	BL4050F
Vacuum function	Max air volume: 13.0 m ³ /min (459 CFM) Dust bag capacity: 50 L (13.2 gal) Continuous use: 30_9 min
(Battery)	BL4050F
Dimensions (L x W x H)	Blower: Nozzle position Shortest - Longest, w/o Vacuum kit: 699 - 830 x 201 x 400 mm (27-1/2 - 32-3/4 x 7-7/8 x 15-3/4")
Net weight	5.0 - 6.1 kg (11.0 - 13.4 lbs.)



40Vmax XGT Cordless Variable 3-Speed Blower

UB002G

40V max

new



Blowing force	Standard nozzle: 3.1 - 3.2 N Garden nozzle: 3.0 - 3.1 N
Max air volume	Blower: 3.5 - 3.6 m ³ /min Vacuum: 2.0 m ³ /min
Max air velocity	Standard nozzle: 98 - 99 m/s Garden nozzle: 75 - 76 m/s
Max sealed suction	5.4 kPa
Continuous use	Standard nozzle, Blower, High / Med. / Low: 20 / 60 / 120 min. BL4025
(Battery)	BL4025
Dimensions (L x W x H)	515 x 156 x 227 mm (20-1/4 x 6-1/8 x 8-15/16")
Net weight	2.0 - 3.5 kg (4.4 - 7.7 lbs.)



Cleaning

18V X2 (36V) LXT BL Brushless Cordless Variable Speed Blower

DUB363

18V x2



No load speed	0 - 7,850 min ⁻¹
Blowing force	14.4 N
Max air volume	13.4 m ³ /min (473 CFM)
Dimensions (L x W x H)	w/ 3-stage telescopic long nozzle: 737 x 786 x 836 mm (193 x 415 x 7-7/16") w/ Vacuum nozzle: 1,396 x 604 x 415 mm (55 x 23-3/4 x 16-3/8")
Net weight	4.5-6.6 kg (9.9-14.6 lbs.)



18V X2 (36V) LXT BL Brushless Cordless Variable 6-Speed Blower

DUB362

18V x2



No load speed	11,400 - 21,500 min ⁻¹
Blowing force	14.4 N
Max air volume	13.4 m ³ /min (473 CFM)
Max air velocity	54 m/s (120 MPH)
Dimensions (L x W x H)	w/ 3-stage telescopic long nozzle: 830 x 880 x 930 mm (205 x 295 x 32-3/4")
Net weight	3.5-4.2 kg (7.7-9.3 lbs.)



18V X2 (36V) LXT Li-Ion Cordless 2-Speed Blower

DUB361

18V x2



No load speed	High: 17,000 min ⁻¹ Low: 10,000 min ⁻¹
Max air volume	High: 4.4 m ³ /min (155 CFM) Low: 2.6 m ³ /min (92 CFM)
Max air velocity	High: 93 m/s (208 MPH) Low: 57 m/s (128 MPH)
Dimensions (L x W x H)	905 x 141 x 194 mm (35-5/8 x 5-5/8 x 7-5/8")
Net weight	3.1-3.2 kg (6.8-7.1 lbs.)



18V LXT BL Cordless Variable Speed Blower Vacuum

DUB187

18V



No load speed	9,000 - 13,500 min ⁻¹
Max air volume (Blower)	4.2 m ³ /min
Max air volume (Vacuum)	6.1 m ³ /min
Max air velocity (Blower)	64 m/s
Max sealed suction	3.3 kPa
Dust bag capacity	25 L
Continuous use	w/ BL1860B: 14 min.
Dimensions (L x W x H)	1,168 x 164 x 416 mm (46 x 6-1/2 x 16-3/8")
Net weight	3.7 - 4.0 kg (8.2 - 8.8 lbs.)



18V LXT BL Brushless Cordless Variable Speed Blower

DUB184

18V



No load speed	0 - 18,000 min ⁻¹
Blowing force	10.9 N
Max air volume	13.0 m ³ /min (459 CFM)
Max air velocity	52.1 m/s (116 MPH)
Continuous use	w/ BL1860B: 12 min. w/ BL1850B: 10 min.
Dimensions (L x W x H)	w/ BL1830B / BL1840B / BL1850B / BL1860B: 825 x 160 x 285 mm (32-1/2 x 6-5/16 x 11-1/4")
Net weight	2.5-3.0 kg (5.4-6.7 lbs.)

LXT BL MOTOR XPT



18V LXT Cordless Variable 3-Speed Blower

DUB185

18V



No load speed	0 - 18,000 min ⁻¹
Blowing force	3.1 N
Max sealed suction	5.8 kPa
Continuous use	w/ BL1850(B), High / Mid / Low: 21 / 50 / 130 min.
Dimensions (L x W x H)	w/ BL1830B / BL1840B / BL1850B / BL1860B: 517 x 156 x 210 mm (20-3/8 x 6-1/8 x 8-1/4")
Net weight	1.6-2.1 kg (3.5-4.6 lbs.)

LXT



18V LXT Cordless Variable 3-Speed Blower

DUB186

18V



No load speed	0 - 18,000 min ⁻¹
Blowing force	2.5 N
Continuous use	w/ BL1850(B), High / Mid / Low: 20 / 50 / 130 min.
Dimensions (L x W x H)	w/ BL1830B / BL1840B / BL1850B / BL1860B: 861 x 156 x 210 mm (34 x 6-1/8 x 8-1/4")
Net weight	1.6-2.1 kg (3.5-4.6 lbs.)

LXT



12Vmax CXT Cordless Variable 3-Speed Blower

UB100D

12V max



No load speed	0 - 15,800 min ⁻¹
Blowing force	1.8 N
Max sealed suction	4.0 kPa
Continuous use	w/ BL1016, High / Mid / Low: 8 / 20 / 45 min.
Dimensions (L x W x H)	w/ BL1041B: 508 x 155 x 202 mm (20 x 6-1/8 x 8")
Net weight	1.4-1.9 kg (3.1-4.2 lbs.)

CXT



12Vmax CXT Cordless Variable 3-Speed Blower

UB101D

12V max



No load speed	0 - 15,800 min ⁻¹
Blowing force	1.6 N
Continuous use	w/ BL1016, High / Mid / Low: 7 / 20 / 45 min.
Dimensions (L x W x H)	w/ BL1041B: 852 x 155 x 202 mm (33-1/2 x 6-1/8 x 8")
Net weight	1.4-1.9 kg (3.1-4.2 lbs.)

CXT



600 W Variable Speed Blower

UB1103

Continuous rating Input	600W
No load speed	0 - 16,000 min ⁻¹
Air pressure	0 - 5.7 kPa
Max air volume	0 - 4.1 m ³ /min
Max air velocity	0 - 91 m/s
Dimensions (L x W x H)	479 x 185 x 178 mm (18-7/8 x 7-1/4 x 7")
Net weight	1.9 - 2.2 kg (4.3 - 4.8 lbs.)



600 W Blower

UB1102



Continuous rating Input	600W
No load speed	16,000 min ⁻¹
Air pressure	5.7 kPa
Max air volume	4.1 m ³ /min
Max air velocity	91 m/s
Dimensions (L x W x H)	479 x 185 x 178 mm (18-7/8 x 7-1/4 x 7")
Net weight	1.9 - 2.2 kg (4.3 - 4.8 lbs.)



40Vmax XGT BL Cordless Dust Blower

AS001G

40V max



Blowing force	Mode 1: 0 - 1.1 N / Mode 4: 0 - 2.8 N
Air pressure	0 - 29.7 kPa
Air volume	0 - 1.1 m ³ /min
Air velocity	0 - 200 m/s
Max sealed suction	10.3 kPa
Continuous use	w/ BL4025, Mode 1: 50 min. w/ BL4025, Mode 2: 25 min. w/ BL4025, Mode 3: 17 min. w/ BL4025, Mode 4: 13 min.
Dimensions (L x W x H)	w/ BL4050F: 182 x 94 x 332 mm (7-1/8 x 3-11/16 x 13-1/8")
Net weight	1.5 - 2.3 kg (3.3 - 5.1 lbs.)

XGT BL MOTOR



18V LXT BL Cordless Air Duster

DAS180

18V



Blowing force	Mode 1: 0 - 1.1 N / Mode 4: 0 - 2.8 N
Air pressure	0 - 29.7 kPa
Air volume	0 - 1.1 m ³ /min
Air velocity	0 - 200 m/s
Max sealed suction	10.3 kPa
Continuous use	w/ BL1860B, Mode 1: 55 min. w/ BL1860B, Mode 2: 30 min. w/ BL1860B, Mode 3: 20 min. w/ BL1860B, Mode 4: 15 min.
Dimensions (L x W x H)	w/ BL1830B / BL1840B / BL1850B / BL1860B: 179 x 92 x 297 mm (7 x 3-5/8 x 11-3/4")
Net weight	1.2 - 1.7 kg (2.6 - 3.7 lbs.)

LXT BL MOTOR



Cleaning

Cordless High Pressure Washer powered by 40Vmax XGT Li-Ion battery (two in parallel or one)

HW001G

40V max



Max permissible pressure	11.5 MPa
Regular flow	Mode 1 / Mode 2 / Mode 3: 3.0 / 4.2 / 5.5 L/min
Max water flow	7.0 L/min
Pump speed	Mode 1 / Mode 2 / Mode 3: 1,870 / 2,580 / 3,350 min ⁻¹
Max feed temperature	40°C
Max suction height	1 m (3.3 ft)
Continuous use	w/ BL4050F x2, Mode 1 / Mode 2 / Mode 3: 60 / 30 / 18 min.
High pressure hose length	5 m (16 ft)
Dimensions (L x W x H)	344 x 383 x 520 mm (13-1/2 x 15-1/8 x 20-1/2")
Net weight	10.3 - 13.4 kg (22.7 - 29.5 lbs.)



18V X2 (36V) LXT BL Cordless 8 MPa High Pressure Washer

DHW080

18V x2



Max permissible pressure	8.0 MPa
Regular flow	High / Low: 330 / 240 L/h (5.5 / 4.0 L/min)
Max water flow	6.3 L/min
Pump speed	High / Low: 3,450 / 2,390 min ⁻¹
Max feed temperature	40°C
Max suction height	1 m (3.3 ft)
Tank	50 L
Continuous use	w/ BL1860B x2, High / Low: 15 / 34 min.
High pressure hose length	5 m (16 ft)
Dimensions (L x W x H)	438 x 218 x 269 mm (17-1/4 x 8-5/8 x 10-5/8")
Net weight	7.1 - 7.7 kg (15.6 - 17.0 lbs.)



15 MPa (150 bar) High Pressure Washer

HW151



Continuous rating Input	2,500W
Max pressure	15 Mpa (150 bar, 2,175 PSI)
Max flow rate	500 L/h
Max feed temperature	50°C (122°F)
High pressure hose length	10 m (33 ft)
Net weight	26.9 kg (59.3 lbs.)

14 MPa (140 bar) High Pressure Washer

HW140



Continuous rating Input	2,300W
Max pressure	14 Mpa (140 bar, 2,030 PSI)
Max flow rate	500 L/h
Max feed temperature	50°C (122°F)
High pressure hose length	10 m (33 ft)
Net weight	29 kg (63.9 lbs.)

13 MPa (130 Bar) High Pressure Washer

HW121



Continuous rating Input	2,100W
Max pressure	13 Mpa (130 bar, 1,885 PSI)
Max flow rate	390 L/h
Max feed temperature	50°C (122°F)
High pressure hose length	8 m (26.3 ft)
Net weight	17.8 kg (39.2 lbs.)

13 MPa (130 Bar) High Pressure Washer with Self-Priming Function

HW1300



Continuous rating Input	1,800W
Max pressure	13 Mpa (130 bar, 1,885 PSI)
Max flow rate	450 L/h
Max feed temperature	40°C (104°F)
High pressure hose length	10 m (33 ft)
Dimensions (L x W x H)	292 x 358 x 830 mm (11-1/2 x 14-1/8 x 32-3/4")
Net weight	12.7 kg (28 lbs.)



12 MPa (120 Bar) High Pressure Washer with Self-Priming Function

HW1200



Continuous rating Input	1,800W
Max pressure	12 Mpa (120 bar, 1,740 PSI)
Max flow rate	420 L/h
Max feed temperature	40°C (104°F)
High pressure hose length	10 m (33 ft)
Dimensions (L x W x H)	292 x 358 x 830 mm (11-1/2 x 14-1/8 x 32-3/4")
Net weight	11 kg (24.3 lbs.)



11 MPa (110 Bar) High Pressure Washer

HW111



Continuous rating Input	1,700W
Max pressure	11 Mpa (110 bar, 1,595 PSI)
Max flow rate	370 L/h
Max feed temperature	50°C (122°F)
High pressure hose length	5.5 m (18 ft)
Net weight	7.4 kg (16.3 lbs.)

12 MPa (120 Bar) High Pressure Washer

HW112



Continuous rating Input	1,600W
Max pressure	12 Mpa (120 bar, 1,740 PSI)
Max flow rate	370 L/h
Max feed temperature	50°C (122°F)
High pressure hose length	5.5 m (18 ft)
Net weight	16.2 kg (35.7 lbs.)

10 MPa (100 Bar) High Pressure Washer

HW102



Continuous rating Input	1,300W
Max pressure	10 Mpa (100 bar, 1,450 PSI)
Max flow rate	360 L/h
Max feed temperature	50°C (122°F)
High pressure hose length	5 m (16.4 ft)
Net weight	5.8 kg (12.8 lbs.)



10 MPa (100 Bar) High Pressure Washer

HW101



Continuous rating Input	1,300W
Max pressure	10 Mpa (100 bar, 1,450 PSI)
Max flow rate	360 L/h
Max feed temperature	50°C (122°F)
High pressure hose length	5 m (16.4 ft)
Net weight	6.5 kg (14.3 lbs.)

18V LXT Cordless 2.4 MPa Pressure Washer

DHW180

18V



Regular pressure	Self-priming, High: 2.0 Mpa / 0.8 Mpa Connection to water supply, High: 2.4 Mpa / Low: 0.8 Mpa
Regular flow rate	High: 2.5 L/min / Low: 1.5 L/min
Max flow rate	w/o Nozzle: 5.3 L/min
Continuous use (Battery)	18, 50 min. BL1830B
(Mode)	High, Low
Max suction height	2.0 m (6.7 ft)
Supplied hose length	6 m (19.7 ft)
Dimensions (L x W x H)	419 x 99 x 239 mm (16-1/2 x 3-7/8 x 9-3/8")
Net weight	2.3 - 2.7 kg (5.1 - 6.0 lbs.)

LXT XPT



40Vmax XGT BL Cordless Polisher Scrubber

PS001G

40V max



No load speed	High: 600 min ⁻¹ / Med.: 350 min ⁻¹ Low: 150 min ⁻¹
Attachment size	Brush: 190 mm (7-1/2") Floor pad: 200 mm (7-7/8")
Continuous use	High: 30 min. / Med.: 50 min. Low: 140 min.
(Battery)	BL4025
Telescopic pole	1,081 - 1,435 mm (42-1/2 - 56-1/2")
Head height	189 mm (7-7/16")
Dimensions (L x W x H)	1,081 - 1,435 x 204 x 361 mm (42-1/2 - 56-1/2 x 8 x 14-1/4")
Net weight	4.5 - 5.6 kg (9.9 - 12.3 lbs.)

XGT BL MOTOR XPT



Lawn care/Grass care



Icon

- Double Insulation
- Variable Speed
- Brake
- Reversing
- Reverse function for debris removal
- Anti-restart function
- Electronic 2-Speed
- Electronic 3-Speed
- Constant Speed
- Soft Start
- Toolless blade change
- Carrying Case



Robotic Mower RM350D

- Keeps the lawn clean at all times without collecting the grass.
- Manages a work area within a boundary wire and mows the lawn efficiently with guide wires.
- Automatically recharges the battery and resumes mowing when the charging is completed.

Washable with water

- The top cover can be removed to wash the entire machine. (not washable with high-pressure water)
- Reduces the burden of off-season maintenance.



Spiral cut

The mower automatically detects high/dense grass and moves slowly in a spiral pattern to gradually cut the grass with a minimum of uncut area.



Max climbing angle: 26°

Mows even on undulating lawn due to the high traveling performance on slopes.

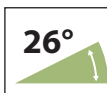

Determining the cutting height

If the lawn is high, user can let the mower automatically mow the lawn down to a desired height gradually in stages over several days by setting the starting height and desired height in the mower. (When using the Competitor H1's robotic mower for this operation, user has to reset the heights after each and every stage.)

Setting range of cutting height 20 - 60 mm
5 mm increments / 9 stages



Mowing start position setting

- Up to 5 start positions for mowing can be set.
- If the setting position is not at the station, the robotic mower travels along wires and starts mowing in a random mode.
- It is possible to control mowing frequency variation in areas where mowing is less frequent, such as at the end of narrow aisles.



Theft-deterrent

Setting a PIN code and the alarm function deter theft of the machine.



Robotic Mower



RM350D

Max work area	3,500 m ²
Continuous use	135 min.
Charging time approx.	40 min
Cutting width	240 mm (9-1/2 ")
No load speed	2,300 min ⁻¹
Cutting height adjustment	Adjustment range: 20 - 60 mm (13/16 - 2-3/8 ")
Max climbing angle	26 °
Dimensions (L x W x H)	700 x 560 x 270 mm (27-1/2 x 22 x 10-5/8 ")
Net weight	13.7 kg (30.2 lbs.)



* Discharge chute required.

	Battery	Battery slots	Class	Deck	Soft no load	Self-Propelled	BL MOTOR	Rear discharge	Side discharge
LM004J	64V max	1	530 mm (21")	Steel	✓	✓	✓	✓	✓*
LM003J			480 mm (18-7/8")		✓	✓	✓	✓	✓*
LM002J			530 mm (21")	Plastics	✓	-	✓	✓	-
LM001J			480 mm (18-7/8")		✓	-	✓	✓	-
LM001C		-	530 mm (21")		✓	✓	✓	-	✓*
LM002G	40V max	2	530 mm (21")	Steel	✓	✓	✓	✓	✓*
LM001G			480 mm (18-7/8")		✓	✓	✓	✓	✓
LM004G	40V max	1	430 mm (17")	Plastics	-	-	-	-	-
LM003G			380 mm (15")		-	-	-	-	-
DLM533	18V x2	4	530 mm (21")	Aluminum	✓	✓	✓	✓	-
DLM537					✓	✓	✓	✓	-
DLM532					✓	✓	✓	✓	-
DLM536					-	✓	✓	✓	-
DLM530					✓	-	✓	✓	-
DLM534					-	-	✓	✓	-
DLM538		2	530 mm (21")	Plastics	✓	-	-	✓	-
DLM539					✓	✓	-	✓	-
DLM480					-	-	-	✓	-
DLM481		4	460 mm (18-1/8")	Steel	✓	✓	✓	-	-
DLM462					-	✓	✓	-	-
DLM465					-	-	✓	-	-
DLM466					-	-	✓	-	-
DLM432		2	430 mm (17")	Plastics	-	-	-	-	-
DLM382					380 mm (15")		-	-	-
DLM330		18V	1	330 mm (13")		-	-	-	-

64Vmax BL Cordless Self-Propelled Lawn Mower

64V max



	LM004J
Cutting width	534 mm (21")
Actual mowing area on a full battery charge	w/ BL64100, Manual push: 2,800 m ² w/ BL64100, Self-propelled: 3,800 m ²
No load speed	Normal mode: 2,800 min ⁻¹ / Soft no-load mode: 2,300 - 2,800 min ⁻¹ Noise reduction mode: 2,300 min ⁻¹
Propelling speed	1.5 - 6.5 km/h
Grass catcher capacity	70 L (2,366 oz)
Cutting height adjustment	Adjustment range: 20 - 100 mm (13/16 - 3-15/16")
Dimensions (L x W x H)	During operation: 1,740 - 1,810 x 595 x 970 - 1,080 mm (68-1/2 - 71-1/4 x 23-1/2 x 38-1/4 - 42-1/2")
Net weight	31.5 - 34.6 kg (69.5 - 76.3 lbs.)

LM003J

Cutting width	480 mm (18-7/8")
Actual mowing area on a full battery charge	w/ BL64100, Manual push: 2,700 m ² w/ BL64100, Self-propelled: 3,700 m ²
No load speed	Normal mode: 3,200 min ⁻¹ / Soft no-load mode: 2,500 - 3,200 min ⁻¹ Noise reduction mode: 2,500 min ⁻¹
Propelling speed	1.5 - 6.5 km/h
Grass catcher capacity	62 L (2,182 oz)
Cutting height adjustment	Adjustment range: 20 - 100 mm (13/16 - 3-15/16")
Dimensions (L x W x H)	During operation: 1,670 - 1,745 x 550 x 965 - 1,075 mm (65-3/4 - 68-3/4 x 21-5/8 x 38 - 42-1/4")
Net weight	30.9 - 33.8 kg (68.1 - 74.5 lbs.)

64Vmax BL Cordless Lawn Mower

64V max



	LM002J
Cutting width	534 mm (21")
Actual mowing area on a full battery charge	w/ BL6440: 1,600 m ²
Continuous use (approx.) on a full battery charge	w/ BL6440: 39 min.
No load speed	Normal mode: 2,800 min ⁻¹ / Soft no-load mode: 2,300 - 2,800 min ⁻¹ Noise reduction mode: 2,300 min ⁻¹
Grass catcher capacity	70 L (2,367 oz)
Cutting height adjustment	Adjustment range: 20 - 100 mm (13/16 - 3-15/16")
Dimensions (L x W x H)	During operation: 1,710 - 1,800 x 585 x 950 - 1,090 mm (67-1/2 - 71 x 23 x 37-1/2 - 43")
Net weight	25.7 - 28.6 kg (56.7 - 63.1 lbs.)

LM001J

Cutting width	480 mm (18-7/8")
Actual mowing area on a full battery charge	w/ BL6440: 1,400 m ²
Continuous use (approx.) on a full battery charge	w/ BL6440: 34 min.
No load speed	Normal mode: 3,200 min ⁻¹ / Soft no-load mode: 2,500 - 3,200 min ⁻¹ Noise reduction mode: 2,500 min ⁻¹
Grass catcher capacity	62 L (2,096 oz)
Cutting height adjustment	Adjustment range: 20 - 100 mm (13/16 - 3-15/16")
Dimensions (L x W x H)	During operation: 1,610 - 1,690 x 530 x 930 - 1,050 mm (63-1/2 - 66-1/2 x 20-7/8 x 36-5/8 - 41-1/4")
Net weight	24.4 - 27.1 kg (53.8 - 59.7 lbs.)

BL Battery Powered 53 cm (21") Self-Propelled Lawn Mower

60V max



	LM001C
Cutting width	534 mm (21")
Actual mowing area on a full battery charge	w/ PDC1200, 2-tooth blade, Manual push: 6,900 m ² w/ PDC1200, 2-tooth blade, Self-propelled: 5,100 m ²
Continuous use	w/ PDC1200, 2-tooth blade, Self-propelled: 120 min. w/ PDC1200, 2-tooth blade, Manual push: 150 min.
No load speed	Normal mode: 2,800 min ⁻¹ / Soft no-load mode: 2,300 - 2,800 min ⁻¹ Noise reduction mode: 2,300 min ⁻¹
Grass box capacity	70 L
Cutting height adjustment	20 - 100 mm (13/16 - 3-15/16")
Propelling speed	2.5 - 5.0 km/h
Dimensions (L x W x H)	1,630 - 1,715 x 590 x 990 - 1,095 mm (64 - 67-1/2 x 23-1/4 x 39 - 43")
Net weight	42.1 - 49.5 kg (92.8 - 109.1 lbs.)

Lawn care/Grass care

40Vmax XGT BL Cordless Self-Propelled Lawn Mower

40V max

XGT BL SOFT NOLOAD XPT



LM002G

Cutting width	534 mm (21")
Actual mowing area on a full battery charge	w/ BL4080F x2, Manual push: 3,400 m ² w/ BL4080F x2, Self-propelled: 2,500 m ²
Continuous use (approx.) on a full battery charge	w/ BL4080F x2, Manual push: 76 min. w/ BL4080F x2, Self-propelled: 56 min.
No load speed	Normal mode: 2,800 min ⁻¹ / Soft no-load mode: 2,300 - 2,800 min ⁻¹ Noise reduction mode: 2,300 min ⁻¹
Propelling speed	1.5 - 5.0 km/h
Grass catcher capacity	70 L (2,366 oz)
Cutting height adjustment	Adjustment range: 20 - 100 mm (13/16 - 3-15/16")
Dimensions (L x W x H)	During operation: 1,740 - 1,810 x 595 x 970 - 1,080 mm (68-1/2 - 71-1/4 x 23-1/2 x 38-1/4 - 42-1/2")
Net weight	29.5 - 34.7 kg (65.0 - 76.5 lbs.)

LM001G

Cutting width	480 mm (18-7/8")
Actual mowing area on a full battery charge	w/ BL4080F x2, Manual push: 2,600 m ² w/ BL4080F x2, Self-propelled: 2,100 m ²
Continuous use (approx.) on a full battery charge	w/ BL4080F x2, Manual push: 71 min. w/ BL4080F x2, Self-propelled: 58 min.
No load speed	Normal mode: 3,200 min ⁻¹ / Soft no-load mode: 2,500 - 3,200 min ⁻¹ Noise reduction mode: 2,500 min ⁻¹
Propelling speed	1.5 - 5.0 km/h
Grass catcher capacity	62 L (2,182 oz)
Cutting height adjustment	Adjustment range: 20 - 100 mm (13/16 - 3-15/16")
Dimensions (L x W x H)	During operation: 1,670 - 1,745 x 550 x 965 - 1,075 mm (65-3/4 - 68-3/4 x 21-5/8 x 38 - 42-1/4")
Net weight	28.0 - 33.0 kg (61.7 - 72.8 lbs.)

40Vmax XGT Cordless Lawn Mower

40V max

XGT XPT



LM004G

Cutting width	430 mm (17")
Actual mowing area on a full battery charge	w/ BL4080F: 830 m ²
Continuous use (approx.) on a full battery charge	w/ BL4080F: 53 min.
No load speed	3,800 min ⁻¹
Grass catcher capacity	50 L (1,691 oz)
Cutting height adjustment	Adjustment range: 20 - 75 mm (13/16 - 2-15/16")
Dimensions (L x W x H)	1,380 - 1,435 x 460 x 1,020 - 1,060 mm (54-1/4 - 56-1/2 x 18-1/8 x 40-1/4 - 41-3/4")
Net weight	16.0 - 18.5 kg (35.3 - 40.8 lbs.)

LM003G

Cutting width	380 mm (15")
Actual mowing area on a full battery charge	w/ BL4080F: 780 m ²
Continuous use (approx.) on a full battery charge	w/ BL4080F: 48 min.
No load speed	3,800 min ⁻¹
Grass catcher capacity	40 L (1,353 oz)
Cutting height adjustment	Adjustment range: 20 - 75 mm (13/16 - 2-15/16")
Dimensions (L x W x H)	1,360 - 1,415 x 450 x 1,020 - 1,060 mm (53-1/2 - 55-3/4 x 17-3/4 x 40-1/4 - 41-3/4")
Net weight	15.1 - 17.5 kg (33.3 - 38.6 lbs.)

18V X2 (36V) LXT BL Cordless 53 cm (21") Self-Propelled Lawn Mower

18V x2

▼ DLM533

LXT BL SOFT NOLOAD XPT



DLM533

Cutting width	534 mm (21")
Actual mowing area on a full battery charge	w/ BL1860B x4, Self-propelled: 1,700 m ²
Continuous run time on full battery charge	w/ BL1860B x4, Self-propelled: 40 min.
No load speed	Standard mode: 2,300, 2,800 min ⁻¹ / Low noise mode: 2,300 min ⁻¹
Propelling speed	2.5 - 5.0 km/h
Grass box capacity	70 L
Cutting height adjustment	Adjustment range: 20 - 100 mm (13/16 - 3-15/16")
Dimensions (L x W x H)	1,655 - 1,740 x 590 x 990 - 1,100 mm (65 - 68-1/2 x 23-1/4 x 39 - 43-1/4")
Net weight	42.8 - 46.7 kg (94.4 - 103 lbs.)

DLM537

Cutting width	534 mm (21")
Actual mowing area on a full battery charge	w/ BL1860B x4, Manual push: 2,300 m ² w/ BL1860B x4, Self-propelled: 1,700 m ²
Continuous run time on full battery charge	w/ BL1860B x4, Manual push: 54 min. w/ BL1860B x4, Self-propelled: 40 min.
No load speed	Standard mode: 2,800 min ⁻¹ / Low noise mode: 2,300 min ⁻¹
Propelling speed	2.5 - 5.0 km/h
Grass box capacity	70 L
Cutting height adjustment	Adjustment range: 20 - 100 mm (13/16 - 3-15/16")
Dimensions (L x W x H)	1,655 - 1,740 x 590 x 990 - 1,100 mm (65 - 68-1/2 x 23-1/4 x 39 - 43-1/4")
Net weight	42.8 - 46.7 kg (94.4 - 103 lbs.)

18V X2 (36V) LXT BL Cordless 53 cm (21") Self-Propelled Lawn Mower

18V x2

▼ DLM532

LXT BL SOFT NOLOAD XPT



DLM532

Cutting width	534 mm (21")
Actual mowing area on a full battery charge	w/ BL1860B x4, Manual push: 2,300 m ² w/ BL1860B x4, Self-propelled: 1,700 m ²
Continuous run time on full battery charge	w/ BL1860B x4, Manual push: 54 min. w/ BL1860B x4, Self-propelled: 40 min.
No load speed	2,300 - 2,800 min ⁻¹ / Noise reduction mode: 2,300 min ⁻¹
Propelling speed	2.5 - 5.0 km/h
Grass box capacity	70 L
Cutting height adjustment	Adjustment range: 20 - 100 mm (13/16 - 3-15/16")
Dimensions (L x W x H)	1,630 - 1,715 x 590 x 990 - 1,195 mm (64 - 67-1/2 x 23-1/4 x 39 - 47")
Net weight	39.0 - 42.8 kg (86.0 - 94.4 lbs.)

DLM536

Cutting width	534 mm (21")
Actual mowing area on a full battery charge	w/ BL1860B x4, Manual push: 2,300 m ² w/ BL1860B x4, Self-propelled: 1,700 m ²
Continuous run time on full battery charge	w/ BL1860B x4, Manual push: 54 min. w/ BL1860B x4, Self-propelled: 40 min.
No load speed	Standard mode: 2,800 min ⁻¹ / Low noise mode: 2,300 min ⁻¹
Propelling speed	2.5 - 5.0 km/h
Grass box capacity	70 L
Cutting height adjustment	Adjustment range: 20 - 100 mm (13/16 - 3-15/16")
Dimensions (L x W x H)	1,630 - 1,715 x 590 x 990 - 1,095 mm (64 - 67-1/2 x 23-1/4 x 39 - 43")
Net weight	39.0 - 42.8 kg (86.0 - 94.4 lbs.)

18V X2 (36V) LXT BL Cordless 53 cm (21") Lawn Mower

18V x2

▼ DLM530

LXT BL SOFT NOLOAD XPT



DLM530

Cutting width	534 mm (21")
Actual mowing area on a full battery charge	w/ BL1860B x4, Manual push: 2,300 m ²
Continuous run time on full battery charge	w/ BL1860B x4, Manual push: 54 min.
No load speed	2,300 - 2,800 min ⁻¹
Grass box capacity	70 L
Cutting height adjustment	Adjustment range: 20 - 100 mm (13/16 - 3-15/16")
Dimensions (L x W x H)	1,630 - 1,715 x 590 x 990 - 1,095 mm (64 - 67-1/2 x 23-1/4 x 39 - 43")
Net weight	35.5 - 39.3 kg (78.3 - 86.6 lbs.)

DLM534

Cutting width	534 mm (21")
Actual mowing area on a full battery charge	w/ BL1860B x4, Manual push: 2,300 m ²
Continuous run time on full battery charge	w/ BL1860B x4, Manual push: 54 min.
No load speed	Standard mode: 2,800 min ⁻¹ / Low noise mode: 2,300 min ⁻¹
Grass box capacity	70 L
Cutting height adjustment	Adjustment range: 20 - 100 mm (13/16 - 3-15/16")
Dimensions (L x W x H)	1,630 - 1,715 x 590 x 990 - 1,095 mm (64 - 67-1/2 x 23-1/4 x 39 - 43")
Net weight	35.5 - 39.3 kg (78.3 - 86.6 lbs.)

18V X2 (36V) LXT Cordless 53 cm (21") Lawn Mower

18V x2

DLM539: Self-Propelled

LXT XPT



DLM539

Cutting width	534 mm (21")
Actual mowing area on a full battery charge	w/ BL1860B x2, Manual push: 800 m ² w/ BL1860B x2, Self-propelled: 700 m ²
Continuous run time on full battery charge	w/ BL1860B x2, Manual push: 25 min. w/ BL1860B x2, Self-propelled: 22 min.
No load speed	3,000 min ⁻¹
Propelling speed	2.5 - 5.0 km/h
Grass box	Capacity: 70 L (2,367 oz)
Cutting height adjustment	Adjustment range: 20 - 100 mm (13/16 - 3-15/16")
Dimensions (L x W x H)	During operation: 1,810 - 1,870 x 580 x 920 - 1,040 mm (71-1/4 - 73-1/2 x 23 x 36-1/4 - 41")
Net weight	27.9 - 30.4 kg (61.5 - 67.0 lbs.)

DLM538

Cutting width	534 mm (21")
Actual mowing area on a full battery charge	w/ BL1860B x2, Manual push: 800 m ²
Continuous run time on full battery charge	w/ BL1860B x2, Manual push: 25 min.
No load speed	3,000 min ⁻¹
Propelling speed	-
Grass box	Capacity: 70 L (2,367 oz)
Cutting height adjustment	Adjustment range: 20 - 100 mm (13/16 - 3-15/16")
Dimensions (L x W x H)	During operation: 1,810 - 1,870 x 580 x 920 - 1,040 mm (71-1/4 - 73-1/2 x 22-3/4 x 36-1/4 - 41")
Net weight	25.5 - 28.0 kg (56.2 - 61.7 lbs.)

18V X2 (36V) LXT Cordless 48 cm (18-7/8") Lawn Mower

18V x2

DLM481: Self-Propelled

LXT XPT



DLM481

Cutting width	480 mm (18-7/8")
Actual mowing area on a full battery charge	w/ BL1860B x2, Manual push: 800 m ² w/ BL1860B x2, Self-propelled: 650 m ²
Continuous run time on full battery charge	w/ BL1860B x2, Manual push: 28 min. w/ BL1860B x2, Self-propelled: 23 min.
No load speed	3,100 min ⁻¹
Propelling speed	2.5 - 5.0 km/h
Grass box	Capacity: 62 L (2,096 oz)
Cutting height adjustment	Adjustment range: 20 - 100 mm (13/16 - 3-15/16")
Dimensions (L x W x H)	During operation: 1,690 - 1,740 x 530 x 930 - 1,060 mm (66-1/2 - 68-1/2 x 20-7/8 x 36-5/8 - 41-3/4")
Net weight	27.1 - 29.3 kg (59.7 - 64.6 lbs.)

DLM480

Cutting width	480 mm (18-7/8")
Actual mowing area on a full battery charge	w/ BL1860B x2, Manual push: 800 m ²
Continuous run time on full battery charge	w/ BL1860B x2, Manual push: 28 min.
No load speed	3,100 min ⁻¹
Propelling speed	-
Grass box	Capacity: 62 L (2,096 oz)
Cutting height adjustment	Adjustment range: 20 - 100 mm (13/16 - 3-15/16")
Dimensions (L x W x H)	During operation: 1,690 - 1,740 x 530 x 930 - 1,060 mm (66-1/2 - 68-1/2 x 20-7/8 x 36-5/8 - 41-3/4")
Net weight	24.5 - 26.8 kg (54.0 - 59.1 lbs.)

Lawn care/Grass care

18V X2 (36V) LXT BL Cordless 46 cm (18") Lawn Mower

18V x2

new

BL XPT



DLM466

Cutting width	460 mm (18-1/8")
Actual mowing area on a full battery charge	960 m ²
(Battery)	BL1860B x 2
Continuous use (Battery)	26 min.
(Battery)	BL1860B x 2
No load speed	Normal mode: 3,300 min ⁻¹ / Noise reduction mode: 2,500 min ⁻¹
Grass box	Capacity: 60 L (2,029 oz)
Cutting height adjustment	Adjustment range: 20 - 75 mm (13/16 - 2-15/16")
Dimensions (L x W x H)	1,270 - 1,440 x 535 x 915 - 1,110 mm (50 - 56-3/4 x 21 x 36 - 43-3/4")
Net weight	22.4 - 26.0kg (49.4 - 57.3lbs.)

18V X2 (36V) LXT BL Cordless 46 cm (18") Self-Propelled Lawn Mower

18V x2

▼ DLM462

LXT BL XPT NOLOAD



DLM462

Cutting width	460 mm (18-1/8")
Actual mowing area on a full battery charge	w/ BL1860B x4, Manual push: 1,900 m ² w/ BL1860B x4, Self-propelled: 1,400 m ²
Continuous run time on full battery charge	w/ BL1860B x4, Manual push: 51 min. w/ BL1860B x4, Self-propelled: 40 min.
No load speed	2,500 - 3,300 min ⁻¹ / Noise reduction mode: 2,500 min ⁻¹
Propelling speed	2.5 - 5.0 km/h
Grass box capacity	60 L
Cutting height adjustment	Adjustment range: 20 - 100 mm (13/16 - 3-15/16")
Dimensions (L x W x H)	1,610 - 1,690 x 535 x 980 - 1,195 mm (63-1/2 - 66-1/2 x 21 x 38-1/2 - 47")
Net weight	35.3 - 39.0 kg (77.8 - 86.0 lbs.)

DLM465

Cutting width	460 mm (18-1/8")
Actual mowing area on a full battery charge	w/ BL1860B x4, Manual push: 1,900 m ² w/ BL1860B x4, Self-propelled: 1,400 m ²
Continuous run time on full battery charge	w/ BL1860B x4, Manual push: 51 min. w/ BL1860B x4, Self-propelled: 40 min.
No load speed	Standard mode: 3,300 min ⁻¹ / Low noise mode: 2,500 min ⁻¹
Propelling speed	2.5 - 5.0 km/h
Grass box capacity	60 L
Cutting height adjustment	Adjustment range: 20 - 100 mm (13/16 - 3-15/16")
Dimensions (L x W x H)	1,610 - 1,690 x 535 x 980 - 1,095 mm (63-1/2 - 66-1/2 x 21 x 38-1/2 - 43")
Net weight	35.3 - 39.0 kg (77.8 - 86.0 lbs.)

18V X2 (36V) LXT Cordless Lawn Mower

18V x2

LXT XPT



DLM432

Cutting width	430 mm (17")
Actual mowing area on a full battery charge	w/ BL1860B x2: 575 m ²
Continuous run time on full battery charge	w/ BL1860B x2: 36 min.
No load speed	3,600 min ⁻¹
Grass catcher capacity	40 L (1,353 oz)
Cutting height adjustment	Adjustment range: 20 - 75 mm (13/16 - 2-15/16")
Dimensions (L x W x H)	During operation: 1,435 - 1,490 x 460 x 1,005 - 1,045 mm (56-1/2 - 58-3/4 x 18-1/8 x 39-1/2 - 41-1/4")
Net weight	16.8 - 17.5 kg (37.0 - 38.6 lbs.)

DLM382

Cutting width	380 mm (15")
Actual mowing area on a full battery charge	w/ BL1860B x2: 560 m ²
Continuous run time on full battery charge	w/ BL1860B x2: 35 min.
No load speed	3,700 min ⁻¹
Grass catcher capacity	40 L (1,353 oz)
Cutting height adjustment	Adjustment range: 20 - 75 mm (13/16 - 2-15/16")
Dimensions (L x W x H)	During operation: 1,380 - 1,410 x 450 x 985 - 1,005 mm (54-1/4 - 55-1/2 x 17-3/4 x 38-3/4 - 39-1/2")
Net weight	16.2 - 16.9 kg (35.7 - 37.3 lbs.)

18V LXT Cordless 33 cm (13") Lawn Mower

18V

LXT XPT



DLM330

Cutting width	330 mm (13")
Actual mowing area on a full battery charge	w/ BL1840B: 270 m ²
Continuous run time on full battery charge	w/ BL1840B: 14 min.
No load speed	4,300 min ⁻¹
Grass box	Capacity: 30 L (1,014 oz)
Cutting height adjustment	Adjustment range: 20 - 75 mm (13/16 - 2-15/16")
Dimensions (L x W x H)	During operation: 1,285 - 1,350 x 375 x 935 - 975 mm (50-1/2 - 53 x 14-3/4 x 36-3/4 - 38-3/8")
Net weight	11.6 - 12.5 kg (25.6 - 27.6 lbs.)

46 cm (18-1/8") 1,800 W Self-Propelled (Single Speed) Electric Lawn Mower



ELM4621

Continuous rating Input	1,800W
Cutting width	460 mm (18-1/8")
Recommended mowing area up to	1,000 m ²
No load speed	2,950 min ⁻¹
Propelling speed	3.6 km/h
Grass box capacity	60 L
Cutting height	20 - 75 mm (13/16 - 2-15/16")
Dimensions (L x W x H)	During operation: 1,790 x 570 x 950 - 1,165 mm (70-1/2 x 22-1/2 x 37-3/8 - 45-7/8")
Net weight	30.5 - 32.2 kg (67.2 - 71.0 lbs.)

46 cm (18-1/8") 1,800 W Electric Lawn Mower



ELM4620

Continuous rating Input	1,800W
Cutting width	460 mm (18-1/8")
Recommended mowing area up to	800 m ²
No load speed	2,950 min ⁻¹
Grass box capacity	60 L
Cutting height	20 - 75 mm (13/16 - 2-15/16")
Dimensions (L x W x H)	During operation: 1,700 x 530 x 950 - 1,165 mm (67 x 22-1/2 x 37-3/8 - 45-7/8")
Net weight	27.7 - 29.2 kg (61.1 - 64.4 lbs.)

41 cm (16-1/8") 1,600 W Electric Lawn Mower

3 in 1 (Lawnmowing / Grass collecting / Mulching)



ELM4121

Continuous rating Input	1,600W
Cutting width	410 mm (16-1/8")
Recommended mowing area up to	600 m ²
No load speed	3,400 min ⁻¹
Grass box capacity	50 L
Cutting height	20 - 75 mm (13/16 - 2-15/16")
Dimensions (L x W x H)	During operation: 1,465 x 530 x 905 - 1,135 mm (57-3/4 x 20-7/8 x 35-5/8 - 44-3/4")
Net weight	17.5 - 19.1 kg (38.6 - 42.1 lbs.)

Lawn care/Grass care

41 cm (16-1/8") 1,600 W Electric Lawn Mower

2 in 1 (Lawnmowing / Grass collecting)



ELM4120

Continuous rating Input	1,600W
Cutting width	410 mm (16-1/8")
Recommended mowing area up to	600 m ²
No load speed	3,400 min ⁻¹
Grass box capacity	45 L
Cutting height	20 - 75 mm (13/16 - 2-15/16")
Dimensions (L x W x H)	During operation: 1,470 x 460 x 955 - 1,230 mm (57-7/8 x 18-1/8 x 37-5/8 - 48-3/8")
Net weight	14.5 kg (32.0 lbs.)

Electric Lawn Mower



ELM3720

Continuous rating Input	1,400W
Cutting width	370 mm (14-1/2")
Recommended mowing area up to	500 m ²
No load speed	3,400 min ⁻¹
Grass box capacity	40 L
Cutting height	20 - 55 mm (13/16 - 2-3/16")
Dimensions (L x W x H)	During operation: 1,330 x 415 x 890 - 1,120 mm (52-3/8 x 16-3/8 x 35 - 44")
Net weight	11.6 kg (25.6 lbs.)

ELM3320

Continuous rating Input	1,200W
Cutting width	330 mm (13")
Recommended mowing area up to	400 m ²
No load speed	3,400 min ⁻¹
Grass box capacity	30 L
Cutting height	20 - 55 mm (13/16 - 2-3/16")
Dimensions (L x W x H)	During operation: 1,230 x 380 x 870 - 1,110 mm (48-1/2 x 15 x 34-1/4 - 43-3/4")
Net weight	10.2 kg (22.5 lbs.)

40Vmax XGT BL Cordless 380mm (15") Scarifier

40V max

XGT BL XPT



UV001G

Cutting width	380 mm (15")
Working depth (Scarifier)	-12 mm (-15/32") to 5 mm (+3/16")
Actual working area on a full battery charge	500 / 510 m ²
(Battery)	BL4080F x2
(Mode)	Scarifying blade / Dethatching blade
Continuous use	38 / 41 min.
(Battery)	BL4080F x2
(Mode)	Scarifying blade / Dethatching blade
No load speed	3,200 min ⁻¹
Foldable handle	Stage: 2
Dimensions (L x W x H)	1,020-1,240 x 680 x 915-1,155 mm (40-1/4-48-3/4 x 26-3/4 x 36-45-1/2")
Net weight	18.7-23.8 kg (41.2-52.5 lbs.)

18V LXT BL Cordless 320 mm (12-5/8") Scarifier

18V

LXT BL XPT



DUV320

Cutting width	320 mm (12-5/8")
Working depth	Adjustment range: -8 / -4 / 0 / 4 mm (-5/16 / -5/32 / 0 / 5/32")
Actual working area on a full battery charge	128 / 122 m ²
(Battery)	BL1860B
(Mode)	Scarifying blade / Dethatching blade
Continuous use	13 / 13 min.
(Battery)	BL1860B
(Mode)	Scarifying blade / Dethatching blade
No load speed	3,300 min ⁻¹
Foldable handle	Stage: 3
Dimensions (L x W x H)	1,035 x 565 x 995 mm (40-3/4 x 22-1/4 x 39-1/4")
Net weight	10.1 - 10.4 kg (22.3 - 22.9 lbs.)

Electric Scarifier



UV3600

UV3200

UV3600

Continuous rating Input	1,800W
Cutting width	360 mm (14-1/5")
Working depth (Scarifier)	-10 / -5 / 0 / 5 mm (-3/8 / -3/16 / 0 / +3/16")
No load speed	3,500 min ⁻¹
Grass catcher capacity	40 L (1,353 oz)
Dimensions (L x W x H)	880 x 590 x 970 mm (34-3/4 x 23-1/4 x 38-1/4")
Net weight	15.3 kg (33.7 lbs.)

UV3200

Continuous rating Input	1,300W
Cutting width	320 mm (12-3/5")
Working depth (Scarifier)	-10 / -5 / 0 / 5 / 10 mm (-3/8 / -3/16 / 0 / +3/16 / +3/8")
No load speed	3,000 min ⁻¹
Grass catcher capacity	30 L
Dimensions (L x W x H)	730 x 580 x 1,050 mm (28-3/4 x 22-3/4 x 41-1/4")
Net weight	12 kg (26.5 lbs.)

45 mm (1-4/5") 2,500 W Electric Shredder



UD2500

Continuous rating Input	2,500W
Max branch	45 mm (1-4/5")
Cutting	40 min ⁻¹
Tank	67 L
Dimensions (L x W x H)	650 x 500 x 880 mm (25-1/2 x 19-3/4 x 34-3/4")
Net weight	27.6 kg (60.8 lbs.)



Lawn care/Grass care

	Battery	Max Output	Handle	Nylon	Plastic	Metal	BL MOTOR	ADT	AFT
UR101C		1,000 W	Offset bike	430mm	255 / 305mm	255mm	✓	✓	✓
UR201C			Loop						
UR202C			Loop	430mm	255 / 305mm	-			
UR012G	40V max x2	2,000 W	Offset bike	480mm	305mm	255 / 305mm	✓	✓	✓
UR013G		1,500 W	Offset bike	450mm	305mm	255mm	✓	-	✓
UR014G			Loop	450mm	-	-			
UR006G	40V max	1,000 W	Offset bike	430mm	255 / 305mm	255mm	✓	✓	✓
UR007G			Loop						
UR008G			Loop	430mm	255 / 305mm	-			
UR002G		550 W	Offset bike	350mm	255mm	230mm	✓	✓	✓
UR003G			Loop						
UR016G		530 W	Offset bike	330mm	255mm	230mm	✓	✓	✓
UR017G			Loop						
DUR369A	18V x2	1,000 W	Offset bike	430mm	255 / 305mm	230 / 255mm	✓	✓	✓
DUR369L			Loop						
DUR369N			Loop	430mm	255 / 305mm	-			
DUR368A		550 W	Offset bike	350mm	255mm	230 / 255mm	✓	✓	✓
DUR368L			Loop						
DUR190U	18V	240W	Offset bike	300mm	255mm	230mm	✓	✓	✓
DUR190L				300mm	255mm	-	✓	✓	-
DUR189				300mm	-	-	✓	-	-
DUR192L		460W	300mm	-	-	✓	-	-	
DUR193		280W	260mm	-	-	-	-	-	
UR100D	12V max	130W	Loop	260mm	230mm	-	-	-	-
UR180D	18V	230W		260mm	-	-	-	-	-
UR140D	14.4V	160W		260mm	-	-	-	-	-
UR3502	AC	-		350mm	-	230mm	-	-	-
UR3501		-		350mm	-	-	-	-	-
UR3500		-	350mm	-	-	-	-	-	
UR2300		-	350mm	-	230mm	-	-	-	
UR3000		-	300mm	-	-	-	-	-	

Lawn care/Grass care

BL ADT AFT Battery Powered 3-Speed Grass Trimmer, Bike Handle

UR101C



No load speed	Metal blade (3 / 2 / 1): 0 - 7,000 / 0 - 5,500 / 0 - 4,600 min ⁻¹ Nylon cutting head (3 / 2 / 1): 0 - 5,500 / 0 - 5,000 / 0 - 4,600 min ⁻¹ Plastic blade (305 mm) (3 / 2 / 1): 0 - 7,000 / 0 - 5,500 / 0 - 4,600 min ⁻¹
Cutting width	Metal blade: 255 mm (10") Nylon cutting head: 430 mm (17") Plastic blade: 305 mm (12")
Spindle size	M10 x 1.25 LH
Dimensions (L x W x H)	1,760 x 628 x 550 mm (69-1/4 x 24-3/4 x 21-5/8")
Net weight	5.2 kg (11.5 lbs.)



BL ADT AFT Battery Powered 3-Speed Grass Trimmer, Loop Handle

UR201C



No load speed	Metal blade (3 / 2 / 1): 0 - 7,000 / 0 - 5,500 / 0 - 4,600 min ⁻¹ Nylon cutting head (3 / 2 / 1): 0 - 5,500 / 0 - 5,000 / 0 - 4,600 min ⁻¹ Plastic blade (305 mm) (3 / 2 / 1): 0 - 7,000 / 0 - 5,500 / 0 - 4,600 min ⁻¹
Cutting width	Metal blade: 255 mm (10") Nylon cutting head: 430 mm (17") Plastic blade: 305 mm (12")
Spindle size	M10 x 1.25 LH
Dimensions (L x W x H)	1,795 x 400 x 269 mm (70-1/2 x 15-3/4 x 10-5/8")
Net weight	4.7 kg (10.4 lbs.)



BL ADT AFT Battery Powered 3-Speed Grass Trimmer, Loop Handle

UR202C

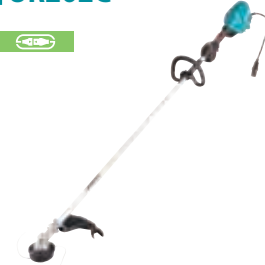

No load speed	Nylon cutting head (3 / 2 / 1): 0 - 5,000 / 0 - 4,600 / 0 - 4,000 min ⁻¹
Cutting width	Nylon cutting head: 430 mm (17") Plastic blade: 305 mm (12")
Spindle size	M10 x 1.25 LH
Dimensions (L x W x H)	1,783 x 226 x 300 mm (70-1/4 x 8-15/16 x 11-7/8")
Net weight	4.4 kg (9.7 lbs.)



40Vmax X2 (80Vmax) XGT BL ADT AFT Cordless 3-Speed Grass Trimmer, Bike Handle

UR012G

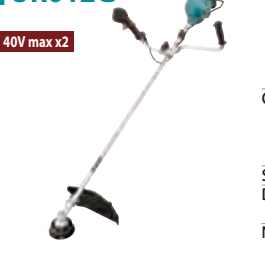

No load speed	Metal blade (3 / 2 / 1): 0 - 6,800 / 0 - 5,000 / 0 - 3,500 min ⁻¹ Nylon cutting head (3 / 2 / 1): 0 - 5,000 / 0 - 4,200 / 0 - 3,500 min ⁻¹ Plastic blade (305 mm) (3 / 2 / 1): 0 - 6,800 / 0 - 5,000 / 0 - 3,500 min ⁻¹
Cutting width	Metal blade: 305 mm (12") Chisel blade: 225 mm (8-7/8") Nylon cutting head: 480 mm (18-7/8") Plastic blade: 305 mm (12")
Spindle size	M10 x 1.25 LH
Dimensions (L x W x H)	w/ Nylon cutting head, w/ BL4050F: 1,829 x 680 x 590 mm (72 x 26-3/4 x 23-1/4")
Net weight	9.3 kg (20.5 lbs.)



40Vmax XGT BL AFT Cordless Grass Trimmer, Bike Handle

UR013G



No load speed	w/ Metal blade/ Plastic blade: 3,500 - 6,700 min ⁻¹ w/ Nylon cutting head: 3,500 - 6,700 min ⁻¹
Cutting width	Metal blade: 255 mm (10") Chisel blade: 225 mm (8-7/8") Nylon cutting head: 450 mm (17-3/4") Plastic blade: 305 mm (12")
Spindle size	M10 x 1.25 LH
Dimensions (L x W x H)	w/ Metal blade, w/ BL4080F: 1,966 x 690 x 546 mm (77-1/2 x 27-1/4 x 21-1/2")
Net weight	7.2 kg (15.9 lbs.)



40Vmax XGT BL AFT Cordless Grass Trimmer, Loop Handle

UR014G



No load speed	w/ Nylon cutting head: 4,000 - 5,700 min ⁻¹
Cutting width	Nylon cutting head: 450 mm (17-3/4")
Spindle size	M10 x 1.25 LH
Dimensions (L x W x H)	w/ Nylon cutting head, w/ BL4080F: 1,958 x 330 x 304 mm (77 x 13 x 12")
Net weight	6.7 kg (14.8 lbs.)



40Vmax XGT BL ADT AFT Cordless 3-Speed Grass Trimmer, Bike Handle

UR006G



No load speed	Metal blade (3 / 2 / 1): 0 - 7,000 / 0 - 5,500 / 0 - 4,600 min ⁻¹ Nylon cutting head (3 / 2 / 1): 0 - 5,500 / 0 - 5,000 / 0 - 4,600 min ⁻¹ Plastic blade (305 mm) (3 / 2 / 1): 0 - 7,000 / 0 - 5,500 / 0 - 4,600 min ⁻¹
Cutting width	Metal blade: 255 mm (10") Nylon cutting head: 430 mm (17") Plastic blade: 305 mm (12")
Spindle size	M10 x 1.25 LH
Dimensions (L x W x H)	w/o Cutting tool, w/ BL4020 / BL4025 / BL4040: 1,815 x 677 x 540 mm (71-1/2 x 26-3/4 x 21-1/4")
Net weight	6.3 kg (13.9 lbs.)



40Vmax XGT BL ADT AFT Cordless 3-Speed Grass Trimmer, Loop Handle

UR007G



No load speed	Metal blade (3 / 2 / 1): 0 - 7,000 / 0 - 5,500 / 0 - 4,600 min ⁻¹ Nylon cutting head (3 / 2 / 1): 0 - 5,500 / 0 - 5,000 / 0 - 4,600 min ⁻¹ Plastic blade (305 mm) (3 / 2 / 1): 0 - 7,000 / 0 - 5,500 / 0 - 4,600 min ⁻¹
Cutting width	Metal blade: 255 mm (10") Nylon cutting head: 430 mm (17") Plastic blade: 305 mm (12")
Spindle size	M10 x 1.25 LH
Dimensions (L x W x H)	w/o Cutting tool, w/ BL4020 / BL4025 / BL4040: 1,815 x 396 x 266 mm (71-1/2 x 15-5/8 x 10-1/2")
Net weight	5.3 - 5.9 kg (11.7 - 13.0 lbs.)



40Vmax XGT BL ADT AFT Cordless 3-Speed Grass Trimmer, Loop Handle

UR008G



No load speed	Nylon cutting head (3 / 2 / 1): 0 - 5,000 / 0 - 4,600 / 0 - 4,000 min ⁻¹ Plastic blade (305 mm) (3 / 2 / 1): 0 - 6,000 / 0 - 4,600 / 0 - 4,000 min ⁻¹
Cutting width	Nylon cutting head: 430 mm (17") Plastic blade: 305 mm (12")
Spindle size	M10 x 1.25 LH
Dimensions (L x W x H)	w/ Nylon cutting head 95M-10L, w/ BL4050F: 1,862 x 224 x 300 mm (73-1/4 x 8-7/8 x 11-3/4")
Net weight	5.0 - 5.7 kg (11.0 - 12.6 lbs.)



40Vmax XGT BL ADT AFT Cordless 3-Speed Grass Trimmer, Bike Handle

UR002G



No load speed	High / Med. / Low: 0 - 6,500 / 5,300 / 3,500 min ⁻¹
Cutting width	Metal blade: 230 mm (9") Nylon cutting head: 350 mm (13-3/4") Plastic blade: 255 mm (10")
Spindle size	M10 x 1.25 LH
Dimensions (L x W x H)	w/o Cutting tool, w/ BL4020 / BL4025 / BL4040: 1,735 x 630 x 500 mm (68-1/4 x 24-3/4 x 19-3/4")
Net weight	4.6 - 5.3 kg (10.1 - 11.6 lbs.)



40Vmax XGT BL ADT AFT Cordless 3-Speed Grass Trimmer, Loop Handle

UR003G

40V max



No load speed	High / Med. / Low: 0 - 6,500 / 5,300 / 3,500 min ⁻¹
Cutting width	Metal blade: 230 mm (9") Nylon cutting head: 350 mm (13-3/4") Plastic blade: 255 mm (10")
Spindle size	M10 x 1.25 LH
Dimensions (L x W x H)	w/o Cutting tool, w/ BL4020 / BL4025 / BL4040: 1,735 x 355 x 230 mm (68-1/4 x 14 x 9")
Net weight	4.1 - 4.7 kg (9.0 - 10.4 lbs.)



40Vmax XGT BL ADT AFT Cordless 3-Speed Grass Trimmer, Bike Handle

UR016G

40V max



No load speed	High / Med. / Low: 6,500 / 5,300 / 3,500 min ⁻¹
Cutting width	Metal blade: 230 mm (9") Nylon cutting head: 330 mm (13") Plastic blade: 255 mm (10")
Spindle size	M10 x 1.25 LH
Dimensions (L x W x H)	w/ Plastic blade, w/ BL4040: 1,890 x 625 x 537 mm (74-1/2 x 24-5/8 x 21-1/8")
Net weight	4.7 - 5.3 kg (10.4 - 11.7 lbs.)



40Vmax XGT BL ADT AFT Cordless 3-Speed Grass Trimmer, Loop Handle

UR017G

40V max



No load speed	High / Med. / Low: 6,500 / 5,300 / 3,500 min ⁻¹
Cutting width	Metal blade: 230 mm (9") Nylon cutting head: 330 mm (13") Plastic blade: 255 mm (10")
Spindle size	M10 x 1.25 LH
Dimensions (L x W x H)	w/ Plastic blade, w/ BL4040: 1,890 x 362 x 265 mm (74-1/2 x 14-1/4 x 10-3/8")
Net weight	4.8 kg (10.6 lbs.)



18V X2 (36V) LXT BL ADT AFT Cordless 3-Speed Grass Trimmer, Bike Handle

DUR369A

18V x2



No load speed	Metal blade (3 / 2 / 1): 0 - 7,000 / 0 - 5,500 / 0 - 4,600 min ⁻¹ Nylon cutting head (3 / 2 / 1): 0 - 5,500 / 0 - 5,000 / 0 - 4,600 min ⁻¹ Plastic blade (305 mm) (3 / 2 / 1): 0 - 7,000 / 0 - 5,500 / 0 - 4,600 min ⁻¹
Cutting width	Metal blade: 255 mm (10") Nylon cutting head: 430 mm (17") Plastic blade: 305 mm (12")
Spindle size	M10 x 1.25 LH
Dimensions (L x W x H)	1,846 x 628 x 530 mm (72-1/2 x 24-3/4 x 20-7/8")
Net weight	5.9 - 6.5 kg (13.0 - 14.3 lbs.)



18V X2 (36V) LXT BL ADT AFT Cordless 3-Speed Grass Trimmer, Loop Handle

DUR369L

18V x2



No load speed	Metal blade (3 / 2 / 1): 0 - 7,000 / 0 - 5,500 / 0 - 4,600 min ⁻¹ Nylon cutting head (3 / 2 / 1): 0 - 5,500 / 0 - 5,000 / 0 - 4,600 min ⁻¹ Plastic blade (305 mm) (3 / 2 / 1): 0 - 7,000 / 0 - 5,500 / 0 - 4,600 min ⁻¹
Cutting width	Metal blade: 255 mm (10") Nylon cutting head: 430 mm (17") Plastic blade: 305 mm (12")
Spindle size	M10 x 1.25 LH
Dimensions (L x W x H)	1,846 x 400 x 269 mm (72-1/2 x 15-3/4 x 10-5/8")
Net weight	5.7 - 6.3 kg (12.6 - 13.9 lbs.)



18V X2 (36V) LXT BL ADT AFT Cordless 3-Speed Grass Trimmer, Loop Handle

DUR369N

18V x2



No load speed	Nylon cutting head (3 / 2 / 1): 0 - 6,000 / 0 - 4,600 / 0 - 4,000 min ⁻¹
Cutting width	Nylon cutting head: 430 mm (17") Plastic blade: 305 mm (12")
Spindle size	M10 x 1.25 LH
Dimensions (L x W x H)	1,834 x 226 x 301 mm (72-1/2 x 8-15/16 x 11-7/8")
Net weight	5.5 - 6.1 kg (12.1 - 13.5 lbs.)



18V X2 (36V) LXT BL ADT AFT Cordless 3-Speed Grass Trimmer, Bike Handle

DUR368A

18V x2



No load speed	High / Med. / Low: 6,500 / 5,300 / 3,500 min ⁻¹
Cutting width	Metal blade: 230 mm (9") Nylon cutting head: 350 mm (13-3/4") Plastic blade: 255 mm (10")
Spindle size	M10 x 1.25 LH
Dimensions (L x W x H)	1,758 x 615 x 442 mm (69-1/4 x 24-1/4 x 17-3/8")
Net weight	4.1 - 4.7 kg (9.0 - 10.5 lbs.)



18V X2 (36V) LXT BL ADT AFT Cordless 3-Speed Grass Trimmer, Loop Handle

DUR368L

18V x2



No load speed	High / Med. / Low: 6,500 / 5,300 / 3,500 min ⁻¹
Cutting width	Metal blade: 230 mm (9") Nylon cutting head: 350 mm (13-3/4") Plastic blade: 255 mm (10")
Spindle size	M10 x 1.25 LH
Dimensions (L x W x H)	1,758 x 362 x 231 mm (69-1/4 x 14-1/4 x 9-1/8")
Net weight	3.9 - 4.5 kg (8.6 - 10.0 lbs.)



18V LXT BL ADT AFT Cordless 3-Speed Grass Trimmer, Bike Handle

DUR190U

18V



No load speed	3,500 - 6,000 min ⁻¹
Cutting width	Metal blade: 230 mm (9") Nylon cutting head: 300 mm (11-3/4") Plastic blade: 255 mm (10")
Spindle size	M10 x 1.25 LH
Dimensions (L x W x H)	1,836 x 610 x 473 mm (72-1/4 x 24 x 18-5/8")
Net weight	3.4 kg (7.5 lbs.)



18V LXT BL ADT AFT Cordless 3-Speed Grass Trimmer, Loop Handle

DUR190L

18V



No load speed	3,500 - 6,000 min ⁻¹
Cutting width	Metal blade: 230 mm (9") Nylon cutting head: 300 mm (11-3/4") Plastic blade: 255 mm (10")
Spindle size	M10 x 1.25 LH
Dimensions (L x W x H)	1,836 x 348 x 236 mm (72-1/4 x 13-3/4 x 9-1/4")
Net weight	3.2 kg (7.1 lbs.)



Lawn care/Grass care

18V LXT BL Cordless 2-Speed Grass Trimmer, Loop Handle

DUR192L

18V



No load speed	High / Low: 0 - 6,000 / 0 - 4,500 min ⁻¹
Cutting width	Nylon cutting head: 300 mm (11-3/4")
Spindle size	M10 x 1.25 LH
Dimensions (L x W x H)	w/ Nylon cutting head, BL1830B / BL1840B / BL1850B / BL1860B: 1,705 x 186 x 246 mm (67 x 7-3/8 x 9-11/16")
Net weight	2.7 - 3.0 kg (6.0 - 6.6 lbs.)



18V LXT BL ADT Cordless Grass Trimmer, Short Telescopic Pipe, Loop Handle

DUR189

18V



No load speed	High / Med. / Low / ADT Mode: 6,000 / 5,000 / 4,000 / 4,000 - 6,000 min ⁻¹
Cutting width	Nylon cutting head: 300 mm (11-3/4") Plastic blade: 255 mm (10")
Spindle size	M8 x 1.25 RH
Dimensions (L x W x H)	1,518 - 1,618 x 258 x 396 mm (59-3/4 - 63-3/4 x 10-1/8 x 15-5/8")
Net weight	3 - 3.3 kg (6.6 - 7.3 lbs.)



18V LXT Li-Ion Cordless Grass Trimmer, Loop Handle

DUR193

18V



No load speed	7,800 min ⁻¹
Cutting width	Nylon cutting head: 260 mm (10-1/4")
Dimensions (L x W x H)	w/ Nylon cutting head, BL1830B / BL1840B / BL1850B / BL1860B: 1,248 - 1,436 x 265 x 358 mm (49-1/4 - 56-1/2 x 10-3/8 x 14-1/8")
Net weight	2.3 - 2.6 kg (5.1 - 5.7 lbs.)



12V max CXT Li-Ion Cordless Grass Trimmer

UR100D

12V max



No load speed	10,000 min ⁻¹
Cutting width	Nylon cutting head: 260 mm (10") Plastic blade: 230 mm (9")
Spindle size	M8 x 1.25 RH
Dimensions (L x W x H)	835 - 1,185 x 267 x 210 - 315 mm (32-7/8 - 46-3/4 x 10-1/2 x 8-1/4 - 12-3/8")
Net weight	1.9 - 2.1 kg (4.3 - 4.6 lbs.)



18V Li-Ion Cordless String Trimmer, G-Battery

UR180D

18V



No load speed	7,800 min ⁻¹
Cutting width	Nylon cutting head: 260 mm (10-1/4")
Dimensions (L x W x H)	1,229 - 1,433 x 267 x 186 - 257 mm (48-1/2 - 56-1/2 x 10-1/2 x 7-3/8 - 10-1/8")
Net weight	2.1 - 2.2 kg (4.7 - 4.8 lbs.)

14.4V Li-Ion Cordless String Trimmer, G-Battery

UR140D

14.4V



No load speed	6,000 min ⁻¹
Cutting width	Nylon cutting head: 260 mm (10-1/4")
Dimensions (L x W x H)	1,229 - 1,433 x 267 x 186 - 257 mm (48-1/2 - 56-1/2 x 10-1/2 x 7-3/8 - 10-1/8")
Net weight	2.1 kg (4.6 lbs.)

Lawn care/
Grass care



The weight may differ depending on the attachment(s), including the battery cartridge.

Lawn care/Grass care

35 cm (13-3/4") 1,000 W Electric Grass Trimmer, Loop Handle

UR3502

Continuous rating Input	1,000W
No load speed	6,500 min ⁻¹
Cutting width	350 mm (13-3/4")
Dimensions (L x W x H)	1,630 x 380 x 300 mm (64 x 15 x 11-3/4")
Net weight	4.9 kg (10.8 lbs.)



35 cm (13-3/4") 1,000 W Electric Grass Trimmer, Bent Shaft, Loop Handle

UR3501

Continuous rating Input	1,000W
No load speed	7,500 min ⁻¹
Cutting width	350 mm (13-3/4")
Dimensions (L x W x H)	1,550 x 410 x 500 mm (61 x 16-1/8 x 19-3/4")
Net weight	4.3 kg (9.6 lbs.)

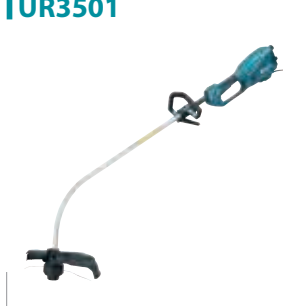

35 cm (13-3/4") 700 W Electric Grass Trimmer, Bent Shaft, Loop Handle

UR3500

Continuous rating Input	700W
No load speed	7,200 min ⁻¹
Cutting width	350 mm (13-3/4")
Dimensions (L x W x H)	1,550 x 410 x 500 mm (61 x 16-1/8 x 19-3/4")
Net weight	4.3 kg (9.5 lbs.)



23 cm (9") 1,000 W Electric Grass Trimmer, Loop Handle

UR2300

Continuous rating Input	1,000W
No load speed	7,800 min ⁻¹
Cutting width	230 mm (9")
Dimensions (L x W x H)	1,630 x 330 x 220 mm (64 x 13 x 8-5/8")
Net weight	4.7 kg (10.3 lbs.)



30 cm (11-3/4") 450 W String Trimmer, Loop Handle

UR3000

Continuous rating Input	450W
No load speed	9,000 min ⁻¹
Cutting width	300 mm (11-3/4")
Dimensions (L x W x H)	1,016~1,256 x 301 x 262 mm (40~49-1/2 x 11-7/8 x 10-3/8")
Net weight	2.6 kg (5.7 lbs.)



40Vmax XGT BL AFT Cordless Edger

UE001G

40V max

Blade diameter	203 mm (8")
Max cutting depth	59 mm (2-5/16")
Spindle thread size	M10 x 1.25 LH
No load speed	0 - 4,800 min ⁻¹
Continuous use	Under load: 18 min. Under no-load: 60 min.
(Battery)	BL4050F
Dimensions (L x W x H)	1,860 x 227 x 303 mm (73-1/4 x 8-15/16 x 11-7/8")
Net weight	6.1 - 7.3 kg (13.4 - 16.1 lbs.)



XGT MOTOR AFT XPT



Lawn care/
Grass care

XGT
40V Li-ion
max



UX01G

Max Output
1.0kW

18v + 18v → **36v**



DUX60

Max Output
0.6kW

18V
LITHIUM-ION



DUX18

Max Output
0.47kW



1,080 mm

Shaft extension attachment
LE400MP

For Pole saw,
Pole hedge trimmer and
Coffee harvester

Lawn care/
Grass care

Brushcutter

- EM402MP / EM403MP*
- EM404MP* / EM405MP*
- EM406MP*

Grass trimmer

- EM408MP
- EM409MP

Rotary Scissors

- EM407MP

Edger

- EE400MP

Pole saw

- EY402MP
- EY403MP

Hedge trimmer

- Straight:** EN410MP
- Angle adjustment:** EN401MP, EN402MP

Ground trimmer

- Angle adjustment:** EN420MP, EN421MP, EN422MP
- T-shaped:** EN424MP, EN425MP

*UX01G / DUX60 only

Straight

Angle adjustment

Angle adjustment

T-shaped



Optional attachments

Attachments		UX01G 40V max	DUX60 18V x2	DUX18 18V
Brushcutter	EM402MP ø230mm Metal blade	●	●	●
	EM403MP (Universal guard) ø420mm Nylon cutting head ø2.0	●	●	—
	EM404MP (Universal guard) ø420mm Nylon cutting head ø2.0	●	●	—
	EM405MP (Narrow guard) Universal guard ø420mm / ø2.0	●	●	—
	EM406MP (Narrow guard) Universal guard ø420mm / ø2.0	●	●	—
Grass trimmer	EM408MP (Universal guard) ø300mm Nylon cutting head ø2.0	●	●	●
	EM409MP (Narrow guard) Universal guard ø330mm / ø2.0	●	●	●
Rotary Scissors	EM407MP	●	●	●
Edger	EE400MP	●	●	●
Pole saw	EY402MP Cutting wide: 250mm	●	●	●
	EY403MP Cutting wide: 300mm	●	●	●
Hedge trimmer	EN410MP Straight	●	●	●
	EN401MP Angle adjustment	●	●	●
	EN402MP Angle adjustment	●	●	●

Attachments		UX01G 40V max	DUX60 18V x2	DUX18 18V
Ground trimmer	EN420MP Angle adjustment	●	●	●
	EN421MP Angle adjustment	●	●	●
	EN422MP Angle adjustment	●	●	●
	EN424MP T-shaped	●	●	●
	EN425MP T-shaped <small>new</small>	●	●	●
Weeding	WA400MP	●	●	●
Cultivator	KR400MP 220mm	●	●	●
	KR401MP 160mm	●	●	●
Coffee harvester	EJ400MP	●	●	●
Power brush	BR400MP	●	●	●
Power sweep	SW400MP	●	●	●
Blower	UB402MP	●	●	●
	UB403MP Low noise <small>new</small>	●	●	●
Pump	PF400MP	●	●	●
Snow Blower	SN400MP	●	●	●
Shaft extension attachment	LE400MP	●	●	●

Lawn care/
Grass care

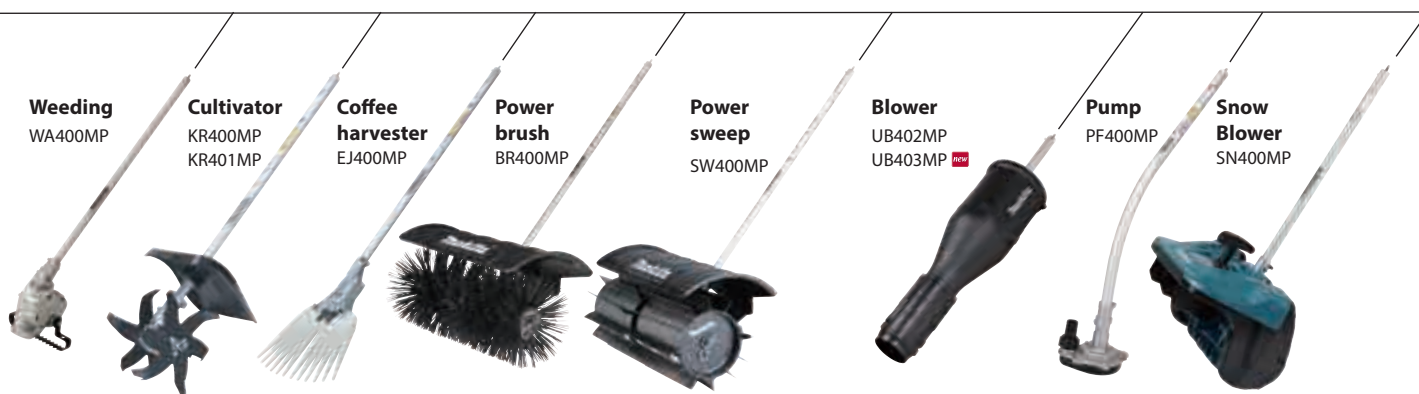

Lawn care/Grass care

40Vmax XGT BL AFT Cordless Multi Function Power Head

UX01G

40V max



No load speed	High: 0 - 9,700 min ⁻¹ Med.: 0 - 8,200 min ⁻¹ Low: 0 - 5,700 min ⁻¹
Dimensions w/o Barrier bar (L x W x H)	w/ BL4050F: 1,027 x 225 x 209 mm (40-1/2 x 8-7/8 x 8-1/4")
Dimensions w/ Barrier bar (L x W x H)	w/ BL4050F: 1,027 x 320 x 209 mm (40-1/2 x 12-5/8 x 8-1/4")
Net weight	4.2-12.6 kg (9.3-27.8 lbs.)

XGT MOTOR **BL AFT XPT**



18V X2 (36V) LXT BL AFT Cordless Multi Function Power Head

DUX60

18V x2



No load speed	High: 0 - 9,700 min ⁻¹ Med.: 0 - 8,200 min ⁻¹ Low: 0 - 5,700 min ⁻¹
Dimensions (L x W x H)	1,011 x 320 x 216 mm (39-3/4 x 12-5/8 x 8-1/2")
Net weight	4.1-8.7 kg (8.9-19.2 lbs.)

LXT MOTOR **BL AFT XPT**



18V LXT BL AFT Cordless Multi Function Power Head

DUX18

18V



No load speed	High: 0 - 9,700 min ⁻¹ Low: 0 - 6,800 min ⁻¹
Dimensions w/o Barrier bar (L x W x H)	w/ BL1830B / BL1840B / BL1850B / BL1860B: 983 x 225 x 175 mm (38-3/4 x 8-7/8 x 6-7/8")
Dimensions w/ Barrier bar (L x W x H)	w/ BL1830B / BL1840B / BL1850B / BL1860B: 983 x 318 x 175 mm (38-3/4 x 12-1/2 x 6-7/8")
Net weight	2.8-10.3 kg (6.2-22.7 lbs.)

LXT MOTOR **BL AFT XPT**



Lawn care/
Grass care

Lawn care/Grass care

18V LXT Li-Ion Cordless 16 cm (6-5/16") Grass Shear

DUM604

18V



Cutting width	160 mm (6-5/16")
Depth adjustment	15 / 20 / 25 mm (9/16 / 13/16 / 1")
Strokes per minute	2,500 min ⁻¹
Continuous use	w/ BL1860B / BL1850B / BL1840B / BL1830B / BL1820B / BL1815N: 250 / 200 / 160 / 125 / 80 / 60 min.
Dimensions (L x W x H)	337 x 177 x 131 mm (13-1/4 x 7 x 5-1/8")
Net weight	1.4 - 1.8 kg (3.2 - 3.9 lbs.)



18V LXT Li-Ion Cordless 11 cm (4-5/16") Grass Shear

DUM111

18V



Cutting width	Grass shear blade: 110 mm (4-5/16") Hedge trimmer blade: 200 mm (7-7/8")
Depth adjustment	15 / 20 / 25 mm (9/16 / 13/16 / 1")
Strokes per minute	2,500 min ⁻¹
Continuous use	w/ BL1850B / BL1815N: 220 / 67 min.
Dimensions (L x W x H)	w/ BL1815N / BL1820B: 330 x 120 x 130 mm (13 x 4-3/4 x 5-1/8")
Net weight	1.4 - 1.8 kg (3.1 - 4.0 lbs.)



12Vmax CXT Li-Ion Cordless 16 cm (6-5/16") Grass Shear

UM600D

12V max



Cutting width	160 mm (6-5/16")
Depth adjustment	15 / 20 / 25 mm (9/16 / 13/16 / 1")
Strokes per minute	2,500 min ⁻¹
Continuous use	w/ BL1041B / BL1021B / BL1016: 90 / 45 / 35 min.
Dimensions (L x W x H)	329 x 177 x 131 mm (13 x 7 x 5-1/8")
Net weight	1.3 - 1.5 kg (2.8 - 3.3 lbs.)



10.8V (12V max) Li-Ion Cordless 16 cm (6-5/16") Grass Shear

UM164D

10.8V



Cutting width	160 mm (6-5/16")
Depth adjustment	10 / 15 / 25 mm (3/8 / 9/16 / 1")
Strokes per minute	2,500 min ⁻¹
Dimensions (L x W x H)	292 x 178 x 130 mm (11-1/2 x 7 x 5-1/8")
Net weight	1.1 - 1.2 kg (2.5 - 2.6 lbs.)



Tree care/Hedge care



Icon

- Double Insulation
- Variable Speed
- Brake
- Reversing
- Anti-restart function
- Electronic 3-Speed
- Torque Limiter
- Constant Speed
- Soft Start
- Anti Vibration
- Automatic Oiling
- Chain Brake
- Toolless blade change
- Carrying Case

40Vmax XGT Brushless Cordless 250/300mm (10/12") Chain Saw

40V max

new



Captive nuts type

XGT BL XPT



UC031G

Chain speed (at no load)	0 - 24.0 m/s
Guide bar length	250, 300 / 300 / 250 mm (10, 12 / 12 / 10")
Oil tank capacity	150 mL (5.1 oz)
Dimensions (L x W x H)	295 x 188 x 203 mm (11-5/8 x 7-3/8 x 8")
Net weight	3.2 - 3.8 kg (7.1 - 8.4 lbs.)

40Vmax XGT BL Cordless Chain Saw

40V max



Captive nuts type

XGT BL XPT



UC005G

UC004G

UC003G

UC002G

Chain speed	0 - 24.8 m/s (0 - 1,490 m/min) (0 - 4,880 FPM)	0 - 24.8 m/s (0 - 1,490 m/min) (0 - 4,880 FPM)	0 - 24.8 m/s (0 - 1,490 m/min) (0 - 4,880 FPM)	0 - 24.8 m/s (0 - 1,490 m/min) (0 - 4,880 FPM)
Guide bar length	400 mm (16")	350 mm (14")	300 mm (12")	250, 250, 250 mm (10, 10, 10")
Chain oil tank volume	200 mL (6.8 USoz)	200 mL (6.8 USoz)	200 mL (6.8 USoz)	200 mL (6.8 USoz)
Dimensions (L x W x H)	w/o Guide bar, w/ Spike bumper, w/ BL4050F: 266 x 194 x 243 mm (10-1/2 x 7-5/8 x 9-9/16")	w/o Guide bar, w/ Spike bumper, w/ BL4050F: 266 x 194 x 243 mm (10-1/2 x 7-5/8 x 9-9/16")	w/o Guide bar, w/ Spike bumper, w/ BL4050F: 266 x 194 x 243 mm (10-1/2 x 7-5/8 x 9-9/16")	w/o Guide bar, w/ Spike bumper, w/ BL4050F: 266 x 194 x 243 mm (10-1/2 x 7-5/8 x 9-9/16")
Net weight	4.0 - 4.7 kg (8.8 - 10.4 lbs.)	4.0 - 4.6 kg (8.8 - 10.1 lbs.)	3.9 - 4.5 kg (8.6 - 9.9 lbs.)	3.8 - 4.7 kg (8.4 - 10.4 lbs.)

40Vmax XGT BL Cordless Chain Saw, Carving Bar

40V max

Captive nuts type



UC007G: Motor Unit Only

XGT BL XPT



UC006G

UC007G

Chain speed	0 - 24.8 m/s (0 - 1,490 m/min) (0 - 4,880 FPM)	0 - 24.8 m/s (0 - 1,490 m/min) (0 - 4,880 FPM)
Guide bar length	250 mm (10")	250, 300, 350 mm (10, 12, 14")
Chain oil tank volume	200 mL (6.8 USoz)	200 mL (6.8 USoz)
Dimensions (L x W x H)	w/o Guide bar, w/ Spike bumper, w/ BL4050F: 266 x 194 x 243 mm (10-1/2 x 7-5/8 x 9-9/16")	w/o Guide bar, w/ Spike bumper, w/ BL4050F: 266 x 194 x 243 mm (10-1/2 x 7-5/8 x 9-9/16")
Net weight	3.9 - 4.5 kg (8.6 - 9.9 lbs.)	3.9 - 4.1 / 4.5 - 4.7 kg (8.6 - 9.0 / 9.9 - 10.4 lbs.)

40Vmax XGT BL Cordless 400/450/500mm (16/18/20") Chain Saw

40V max

new



Captive nuts type

XGT BL XPT IPX4M



UC030G

Chain speed (at no load)	0 - 20.0, 24.5, 29.0 m/s
Chain type	95TXL / 22BPX
Chain pitch	0.325"
Chain gauge	1.3 / 1.6 mm (0.05 / 0.063")
Guide bar length	400, 450, 500 / 500 mm (16, 18, 20 / 20")
Chain oil tank volume	260 mL (8.8 USoz)
Dimensions (L x W x H)	449 x 232 x 280 mm (17-3/4 x 9-1/8 x 11")
Net weight	6.6 - 7.6 / 6.7 - 7.6 / 6.8 - 7.8 kg (14.6 - 16.8 / 14.8 - 16.8 / 15.0 - 17.2 lbs.)

40Vmax XGT BL Brushless Cordless Chain Saw

40V max



Captive nuts type

XGT BL XPT



UC026G

UC025G

UC024G

Chain speed	0 - 25.5 m/s	0 - 25.5 m/s	0 - 25.5 m/s
Guide bar length	400 mm (16")	350 mm (14")	300 mm (12")
Chain oil tank volume	200 mL (6.8 USoz)	200 mL (6.8 USoz)	200 mL (6.8 USoz)
Dimensions (L x W x H)	w/o Guide bar: 430 x 219 x 271 mm (17 x 8-5/8 x 10-5/8")	w/o Guide bar: 430 x 219 x 271 mm (17 x 8-5/8 x 10-5/8")	w/o Guide bar: 430 x 219 x 271 mm (17 x 8-5/8 x 10-5/8")
Net weight	5.1 - 5.4 kg (11.2 - 11.9 lbs.)	5.0 - 5.4 kg (11.0 - 11.9 lbs.)	4.9 - 5.3 kg (10.8 - 11.7 lbs.)

Tree care/Hedge care

40Vmax XGT BL Brushless Cordless Chain Saw, Tool-less Tension Adjustment

40V max



Toolless type

XGT BL MOTOR XPT



	UC023G	UC022G	UC021G
Chain speed	0 - 25.5 m/s	0 - 25.5 m/s	0 - 25.5 m/s
Guide bar length	400 mm (16")	350 mm (14")	300 mm (12")
Chain oil tank volume	200 mL (6.8 USoz)	200 mL (6.8 USoz)	200 mL (6.8 USoz)
Dimensions (L x W x H)	w/o Guide bar: 430 x 225 x 271 mm (17 x 8-7/8 x 10-5/8")	w/o Guide bar: 430 x 225 x 271 mm (17 x 8-7/8 x 10-5/8")	w/o Guide bar: 430 x 225 x 271 mm (17 x 8-7/8 x 10-5/8")
Net weight	5.1 - 5.5 kg (11.2 - 12.1 lbs.)	5.1 - 5.4 kg (11.2 - 11.9 lbs.)	5.0 - 5.3 kg (11.0 - 11.7 lbs.)

40Vmax XGT BL Brushless Cordless Chain Saw

40V max



Captive nuts type

XGT BL MOTOR XPT



	UC013G	UC012G	UC011G	UC010G
Chain speed	0 - 25.5 m/s (0 - 1,530 m/min) (0 - 5,020 FPM)	0 - 25.5 m/s (0 - 1,530 m/min) (0 - 5,020 FPM)	0 - 25.5 m/s (0 - 1,530 m/min) (0 - 5,020 FPM)	0 - 25.5 m/s (0 - 1,530 m/min) (0 - 5,020 FPM)
Guide bar length	450 mm (18")	400 mm (16")	350 mm (14")	300 mm (12")
Chain oil tank volume	260 mL (8.8 USoz)	260 mL (8.8 USoz)	260 mL (8.8 USoz)	260 mL (8.8 USoz)
Dimensions (L x W x H)	w/o Guide bar: 445 x 230 x 275 mm (17-1/2 x 9 x 10-7/8")	w/o Guide bar: 446 x 233 x 274 mm (17-1/2 x 9-1/8 x 10-3/4")	w/o Guide bar: 445 x 230 x 275 mm (17-1/2 x 9 x 10-7/8")	w/o Guide bar: 445 x 230 x 275 mm (17-1/2 x 9 x 10-7/8")
Net weight	6.1 - 7.4 kg (13.4 - 16.3 lbs.)	6.0 - 6.5 kg (13.2 - 14.4 lbs.)	6.1 - 7.4 kg (13.4 - 16.3 lbs.)	6.1 - 7.4 kg (13.4 - 16.3 lbs.)

40Vmax XGT BL Brushless Cordless Chain Saw, Tool-less Tension Adjustment

40V max



Toolless type

XGT BL MOTOR XPT



	UC017G	UC016G	UC015G	UC014G
Chain speed	0 - 25.5 m/s (0 - 1,530 m/min) (0 - 5,020 FPM)	0 - 25.5 m/s (0 - 1,530 m/min) (0 - 5,020 FPM)	0 - 25.5 m/s (0 - 1,530 m/min) (0 - 5,020 FPM)	0 - 25.5 m/s (0 - 1,530 m/min) (0 - 5,020 FPM)
Guide bar length	450 mm (18")	400 mm (16")	350 mm (14")	300 mm (12")
Chain oil tank volume	260 mL (8.8 USoz)	260 mL (8.8 USoz)	260 mL (8.8 USoz)	260 mL (8.8 USoz)
Dimensions (L x W x H)	w/o Guide bar: 445 x 234 x 275 mm (17-1/2 x 9-1/4 x 10-7/8")	w/o Guide bar: 445 x 234 x 275 mm (17-1/2 x 9-1/4 x 10-7/8")	w/o Guide bar: 445 x 234 x 275 mm (17-1/2 x 9-1/4 x 10-7/8")	w/o Guide bar: 445 x 234 x 275 mm (17-1/2 x 9-1/4 x 10-7/8")
Net weight	6.2 - 7.5 kg (13.7 - 16.5 lbs.)	6.2 - 7.5 kg (13.7 - 16.5 lbs.)	6.2 - 7.5 kg (13.7 - 16.5 lbs.)	6.2 - 7.5 kg (13.7 - 16.5 lbs.)

40Vmax XGT BL Brushless Cordless Chain Saw

40V max



Captive nuts type,
Motor Unit Only

XGT BL MOTOR XPT



	UC020G
Chain speed	0 - 25.5 m/s (0 - 1,530 m/min) (0 - 5,020 FPM)
Chain oil tank volume	260 mL (8.8 USoz)
Dimensions (L x W x H)	445 x 230 x 275 mm (17-1/2 x 9 x 10-7/8")
Net weight	6.2 - 7.4 kg (13.7 - 16.3 lbs.)

18V X2 (36V) LXT BL Brushless Cordless Chain Saw

18V x2



Captive nuts type

LXT BL MOTOR XPT



	DUC406	DUC356	DUC306
Chain speed	0 - 20 m/s (0 - 1,200 m/min) (0 - 3,940 FPM)	0 - 20 m/s (0 - 1,200 m/min) (0 - 3,940 FPM)	0 - 20 m/s (0 - 1,200 m/min) (0 - 3,940 FPM)
Guide bar length	400 mm (16")	350 mm (14")	300 mm (12")
Chain oil tank volume	200 mL (6.8 USoz)	200 mL (6.8 USoz)	200 mL (6.8 USoz)
Dimensions (L x W x H)	270 x 206 x 232 mm (10-5/8 x 8-1/8 x 9-1/8")	270 x 206 x 232 mm (10-5/8 x 8-1/8 x 9-1/8")	270 x 206 x 232 mm (10-5/8 x 8-1/8 x 9-1/8")
Net weight	4.9 kg (10.9 lbs.)	4.9 kg (10.8 lbs.)	4.8 kg (10.6 lbs.)

18V X2 (36V) LXT BL Brushless Cordless 25 cm (10") Chain Saw

18V x2



Captive nuts type

LXT BL MOTOR XPT



DUC256C:
Carving Bar

	DUC256	DUC256C
Chain speed	0 - 20 m/s (0 - 1,200 m/min) (0 - 3,940 FPM)	0 - 20 m/s (0 - 1,200 m/min) (0 - 3,940 FPM)
Guide bar length	250 mm (10")	250 mm (10")
Chain oil tank volume	200 mL (6.8 USoz)	200 mL (6.8 USoz)
Dimensions (L x W x H)	270 x 206 x 232 mm (10-5/8 x 8-1/8 x 9-1/8")	270 x 206 x 232 mm (10-5/8 x 8-1/8 x 9-1/8")
Net weight	4.7 kg (10.4 lbs.)	4.7 kg (10.4 lbs.)

18V X2 (36V) LXT BL Brushless Cordless Chain Saw

18V x2



Toolless type

LXT BL MOTOR XPT



	DUC400	DUC353	DUC303
Chain speed	0 - 20 m/s (0 - 1,200 m/min) (0 - 3,940 FPM)	0 - 20 m/s (0 - 1,200 m/min) (0 - 3,940 FPM)	0 - 20 m/s (0 - 1,200 m/min) (0 - 3,940 FPM)
Guide bar length	400 mm (16")	350 mm (14")	300 mm (12")
Chain oil tank volume	200 mL	200 mL	200 mL
Dimensions (L x W x H)	w/o Guide bar: 443 x 215 x 235 mm (17-1/2 x 8-1/2 x 9-1/4")	w/o Guide bar: 443 x 215 x 235 mm (17-1/2 x 8-1/2 x 9-1/4")	w/o Guide bar: 443 x 215 x 235 mm (17-1/2 x 8-1/2 x 9-1/4")
Net weight	4.6 - 5.5 kg (10.2 - 12.1 lbs.)	4.6 - 5.5 kg (10.2 - 12.1 lbs.)	4.6 - 5.5 kg (10.2 - 12.1 lbs.)

Tree care/Hedge care

18V X2 (36V) LXT BL Brushless Cordless Chain Saw

18V x2



Captive nuts type

LXT BL XPT



	DUC405	DUC355	DUC305
Chain speed	0 - 20 m/s (0 - 1,200 m/min) (0 - 3,940 FPM)	0 - 20 m/s (0 - 1,200 m/min) (0 - 3,940 FPM)	0 - 20 m/s (0 - 1,200 m/min) (0 - 3,940 FPM)
Guide bar length	400 mm (16")	350 mm (14")	300 mm (12")
Chain oil tank volume	200 mL	200 mL	200 mL
Dimensions (L x W x H)	w/o Guide bar: 443 x 211 x 235 mm (17-1/2 x 8-5/16 x 9-1/4")	w/o Guide bar: 443 x 211 x 235 mm (17-1/2 x 8-5/16 x 9-1/4")	w/o Guide bar: 443 x 211 x 235 mm (17-1/2 x 8-5/16 x 9-1/4")
Net weight	4.8 kg (12.1 lbs.)	4.7 - 5.4 kg (10.4 - 11.8 lbs.)	4.6 - 5.3 kg (10.2 - 11.6 lbs.)

18V LXT BL Brushless Cordless Chain Saw

18V

new



Captive nuts type

LXT BL XPT



	DUC258
Chain speed	0 - 24 m/s (0 - 1,440 m/min)
Guide bar length	250 mm (10")
Chain oil tank volume	140 mL
Dimensions (L x W x H)	w/o Guide bar, w/ BL1860B: 287x181x194 mm (11-1/4"x7-1/8"x7-5/8")
Net weight	3.0 kg (6.6 lbs.)

18V LXT BL Brushless Cordless Chain Saw

18V



Toolless type

LXT BL XPT



	DUC407	DUC357	DUC307
Chain speed	7.7 m/s (460 m/min) (1,520 FPM)	7.7 m/s (460 m/min) (1,520 FPM)	7.7 m/s (460 m/min) (1,520 FPM)
Guide bar length	400 mm (16")	350 mm (14")	300 mm (12")
Chain oil tank volume	150 mL (5.1 USoz)	150 mL (5.1 USoz)	150 mL (5.1 USoz)
Dimensions (L x W x H)	w/o Guide bar: 428 x 214 x 234 mm (16-7/8 x 8-3/8 x 9-1/4")	w/o Guide bar: 428 x 214 x 234 mm (16-7/8 x 8-3/8 x 9-1/4")	w/o Guide bar: 428 x 214 x 234 mm (16-7/8 x 8-3/8 x 9-1/4")
Net weight	4.2 - 4.4 kg (9.3 - 9.7 lbs.)	4.2 - 4.4 kg (9.3 - 9.7 lbs.)	4.2 - 4.4 kg (9.3 - 9.7 lbs.)

18V LXT Li-Ion Cordless 11.5 cm (4-1/2") Chain Saw

18V



Toolless type

LXT



	DUC122
Chain speed	5.0 m/s (300 m/min) (980 FPM)
Guide bar length	115 mm (4-1/2")
Chain oil tank volume	80 mL (2.7 USoz)
Dimensions (L x W x H)	w/ Guide bar & Saw chain: 422 x 195 x 215 mm (16-5/8 x 7-5/8 x 8-1/2")
Net weight	2.6 kg (5.7 lbs.)

Tree care/
Hedge care



2,000 W Electric Chain Saw, Toolless Tension Adjustment



Toolless type

	UC4551A	UC4051A	UC3551A	UC3051A
Continuous rating Input	2,000W	2,000W	2,000W	2,000W
Guide bar length	450 mm (18")	400 mm (16")	350 mm (14")	300 mm (12")
Chain speed per minute	870 m (2,900 ft)	870 m (2,900 ft)	870 m (2,900 ft)	870 m (2,900 ft)
Dimensions (L x W x H)	505 x 200 x 220 mm (19-7/8 x 7-7/8 x 8-5/8")	505 x 200 x 220 mm (19-7/8 x 7-7/8 x 8-5/8")	505 x 200 x 220 mm (19-7/8 x 7-7/8 x 8-5/8")	505 x 200 x 220 mm (19-7/8 x 7-7/8 x 8-5/8")
Net weight	5.7 kg (12.4 lbs.)	5.6 kg (12.3 lbs.)	5.5 kg (12.1 lbs.)	5.4 kg (11.9 lbs.)



2,000 W Electric Chain Saw



Captive nuts type

	UC4550A	UC4050A	UC3550A	UC3050A
Continuous rating Input	2,000W	2,000W	2,000W	2,000W
Guide bar length	450 mm (18")	400 mm (16")	350 mm (14")	300 mm (12")
Chain speed per minute	870 m (2,900 ft)	870 m (2,900 ft)	870 m (2,900 ft)	870 m (2,900 ft)
Dimensions (L x W x H)	505 x 196 x 220 mm (19-7/8 x 7-3/4 x 8-5/8")	505 x 196 x 220 mm (19-7/8 x 7-3/4 x 8-5/8")	505 x 196 x 220 mm (19-7/8 x 7-3/4 x 8-5/8")	505 x 196 x 220 mm (19-7/8 x 7-3/4 x 8-5/8")
Net weight	5.7 kg (12.5 lbs.)	5.6 kg (12.2 lbs.)	5.5 kg (12.1 lbs.)	5.4 kg (11.9 lbs.)



1,800 W Electric Chain Saw, Toolless Tension Adjustment



Toolless type

	UC4041A	UC3541A	UC3041A
Continuous rating Input	1,800W	1,800W	1,800W
Guide bar length	400 mm (16")	350 mm (14")	300 mm (12")
Chain speed per minute	870 m (2,900 ft)	870 m (2,900 ft)	870 m (2,900 ft)
Dimensions (L x W x H)	455 x 245 x 200 mm (17-7/8 x 9-5/8 x 7-7/8")	455 x 245 x 200 mm (17-7/8 x 9-5/8 x 7-7/8")	455 x 245 x 200 mm (17-7/8 x 9-5/8 x 7-7/8")
Net weight	4.7 kg (10.5 lbs.)	4.7 kg (10.3 lbs.)	4.6 kg (10.1 lbs.)



40Vmax XGT BL Cordless 150 mm (6") Pruning Saw

40V max



Toolless type

	UC029G
Chain speed (at no load)	8.0 m/s
Saw chain	Type: 80TXL Pitch: 0.325" Gauge: 1.1 mm (0.043") Guide bar length: 150 mm (6")
Oil tank capacity	55 mL (1.9 oz)
Dimensions (L x W x H)	474 x 95 x 255 mm (18-5/8 x 3-3/4 x 10")
Net weight	2.1 - 2.4 kg (4.6 - 5.3 lbs.)

XGT BL XPT



18V LXT BL Cordless Pruning Saw

18V



Toolless type

	DUC150	DUC101
Chain speed (at no load)	8.0 m/s	8.0 m/s
Saw chain	Type: 80TXL Pitch: 0.325" Gauge: 1.1 mm (0.043") Guide bar length: 150 mm (6")	Type: 80TXL Pitch: 0.325" Gauge: 1.1 mm (0.043") Guide bar length: 100 mm (4")
Chain oil tank volume	55 mL (1.9 USoz)	55 mL (1.9 USoz)
Dimensions (L x W x H)	w/ BL1830B / BL1840B / BL1850B / BL1860B: 459 x 90 x 249 mm (18 x 3-1/2 x 9-3/4")	w/ BL1830B / BL1840B / BL1850B / BL1860B: 408 x 90 x 249 mm (16 x 3-1/2 x 9-3/4")
Net weight	1.7 - 2.0 kg (3.7 - 4.4 lbs.)	1.6 - 2.0 kg (3.5 - 4.4 lbs.)

LXT BL XPT



12Vmax CXT BL Cordless 100 mm (4") Pruning Saw

12V max



Toolless type

	UC100D
Chain speed (at no load)	8.0 m/s
Saw chain	Type: 80TXL Pitch: 0.325" Gauge: 1.1 mm (0.043") Guide bar length: 100 mm (4")
Chain oil tank volume	55 mL (1.9 USoz)
Dimensions (L x W x H)	w/ BL1041B: 398 x 90 x 226 mm (15-5/8 x 3-1/2 x 8-7/8")
Net weight	1.5 - 1.6 kg (3.3 - 3.5 lbs.)

CXT BL XPT



Tree care/Hedge care

40Vmax XGT BL AFT Cordless Telescopic Pole Saw

40V max



XGT **BL** **AFT** **XPT**



	UA004G	UA002G
Guide bar length	300 mm (11-3/4")	250 mm (10")
Chain speed	20.0 m/s (1,200 m/min) (3,940 FPM)	0 - 20.0 m/s (0 - 1,200 m/min) (0 - 3,940 FPM)
Oil tank capacity	160 mL	160 mL
Dimensions (L x W x H)	w/ Guide bar & Saw chain, w/ BL4050F/ BL4080F: 2,812 - 4,044 x 156 x 192 mm (110-1/2 - 159 x 6-1/8 x 7-9/16")	w/ Guide bar & Saw chain, w/ BL4050F/ BL4080F: 2,765 - 3,997 x 156 x 192 mm (109 - 3,997 x 6-1/8 x 7-9/16")
Net weight	7.8 - 9.1 kg (17.2 - 20.1 lbs.)	7.7 - 8.9 kg (17.0 - 19.6 lbs.)

40Vmax XGT BL AFT Cordless Pole Saw

40V max



XGT **BL** **AFT** **XPT**



	UA003G	UA001G
Guide bar length	300 mm (12")	250 mm (10")
Chain speed	0 - 20 m/s (0 - 1,200 m/min) (0 - 3,940 FPM)	0 - 20 m/s (0 - 1,200 m/min) (0 - 3,940 FPM)
Dimensions (L x W x H)	w/ Guide bar & Saw chain, w/ BL4050F/ BL4080F: 2,526 x 156 x 192 mm (99-1/2 x 6-1/8 x 7-9/16")	w/o Guide bar: 2,230 x 156 x 187 mm (88 x 6-1/8 x 7-3/8")
Net weight	6.1 - 7.4 kg (13.4 - 16.3 lbs.)	6.0 - 7.2 kg (13.2 - 15.9 lbs.)

18V X2 (36V) LXT BL AFT Cordless Telescopic Pole Saw

18V x2



LXT **BL** **AFT** **XPT**



	DUA301	DUA251
Guide bar length	300 mm (12")	250 mm (10")
Saw chain	Gauge: 1.1 / 1.3 mm (0.043 / 0.050") Pitch: 3/8"	Gauge: 1.1 / 1.3 mm (0.043 / 0.050") Pitch: 3/8"
Chain speed	0 - 20.0 m/s (0 - 1,200 m/min) (0 - 3,940 FPM)	0 - 20.0 m/s (0 - 1,200 m/min) (0 - 3,940 FPM)
Oil tank capacity	160 mL	160 mL
Dimensions (L x W x H)	w/o Guide bar: 2,530 - 3,762 x 155 x 191 mm (99-1/2 - 148 x 6-1/8 x 7-1/2")	w/ Guide bar & Saw chain: 2,770 - 4,002 x 155 x 191 mm (109 - 157-1/2 x 6-1/8 x 7-1/2")
Net weight	7.7 - 8.5 kg (17.1 - 18.7 lbs.)	6.1 kg (13.5 lbs.)

18V X2 (36V) LXT BL AFT Cordless Pole Saw

18V x2



LXT **BL** **AFT** **XPT**



	DUA300	DUA250
Guide bar length	300 mm (12")	250 mm (10")
Saw chain	Pitch: 3/8" Gauge: 1.1 / 1.3 mm (0.043 / 0.050")	Pitch: 3/8" Gauge: 1.1 / 1.3 mm (0.043 / 0.050")
Chain speed	0 - 20.0 m/s (0 - 1,200 m/min) (0 - 3,940 FPM)	0 - 20.0 m/s (0 - 1,200 m/min) (0 - 3,940 FPM)
Dimensions (L x W x H)	w/o Guide bar: 2,238 x 155 x 191 mm (88 x 6-1/8 x 7-1/2")	w/o Guide bar: 2,238 x 155 x 191 mm (88 x 6-1/8 x 7-1/2")
Net weight	6.1 - 6.9 kg (13.5 - 15.2 lbs.)	6.1 - 6.9 kg (13.5 - 15.0 lbs.)

18V LXT BL 20 cm (8") Cordless Pole Saw

18V



LXT **BL** **XPT**



	DUA200
Guide bar length	200 mm (8")
Saw chain	Type: 80TXL Pitch: 0.325" Gauge: 1.1 mm (0.043")
Chain speed	6.7 m/s
Oil tank capacity	55 mL (1.9 oz)
Dimensions (L x W x H)	1,620 - 2,520 x 85 x 134 mm (63-3/4 - 99 x 3-3/8 x 5-1/4")
Net weight	3.2 - 3.5 kg (7.1 - 7.7 lbs.)



40Vmax XGT BL Brushless Cordless Hedge Trimmer

40V max



Sharp edge curved Blade



	UH004G	UH005G
Blade length	600 mm (23-5/8")	750 mm (29-1/2")
Strokes per minute	High / Med. / Low: 5,000 / 3,600 / 2,000 min ⁻¹	High / Med. / Low: 5,000 / 3,600 / 2,000 min ⁻¹
Tooth spacing	35 mm (1-3/8")	35 mm (1-3/8")
Max cutting capacity	23.5 mm (15/16")	23.5 mm (15/16")
Continuous use	w/ BL4040, High: 85 min. w/ BL4040, Med.: 160 min. w/ BL4040, Low: 370 min.	w/ BL4040, High: 80 min. w/ BL4040, Med.: 155 min. w/ BL4040, Low: 365 min.
Dimensions (L x W x H)	w/ BL4050F: 1,120 x 223 x 214 mm (44 x 8-3/4 x 8-3/8")	w/ BL4050F: 1,263 x 223 x 214 mm (49-3/4 x 8-3/4 x 8-3/8")
Net weight	4.3 - 4.9 kg (9.5 - 10.8 lbs.)	4.5 - 5.1 kg (9.9 - 11.2 lbs.)

40Vmax XGT BL Brushless Cordless Hedge Trimmer

40V max



Sharp edge Blade



	UH006G	UH007G
Blade length	600 mm (23-5/8")	750 mm (29-1/2")
Strokes per minute	High / Med. / Low: 4,000 / 3,000 / 2,000 min ⁻¹	High / Med. / Low: 4,000 / 3,000 / 2,000 min ⁻¹
Tooth spacing	38 mm (1-1/2")	38 mm (1-1/2")
Max cutting capacity	25.0 mm (1")	25.0 mm (1")
Continuous use	w/ BL4040, High: 65 min. w/ BL4040, Med.: 110 min. w/ BL4040, Low: 195 min.	w/ BL4040, High: 65 min. w/ BL4040, Med.: 105 min. w/ BL4040, Low: 185 min.
Dimensions (L x W x H)	w/ BL4050F: 1,123 x 223 x 214 mm (44-1/2 x 8-3/4 x 8-3/8")	w/ BL4050F: 1,274 x 223 x 214 mm (50-1/4 x 8-3/4 x 8-3/8")
Net weight	4.4 - 5.0 kg (9.7 - 11.0 lbs.)	4.6 - 5.2 kg (10.1 - 11.5 lbs.)

40Vmax XGT BL Brushless Cordless Hedge Trimmer

40V max



Standard Blade



	UH008G	UH009G
Blade length	600 mm (23-5/8")	750 mm (29-1/2")
Strokes per minute	High / Med. / Low: 5,000 / 3,600 / 2,000 min ⁻¹	High / Med. / Low: 5,000 / 3,600 / 2,000 min ⁻¹
Tooth spacing	35 mm (1-3/8")	35 mm (1-3/8")
Max cutting capacity	21.5 mm (7/8")	21.5 mm (7/8")
Continuous use	w/ BL4040, High: 80 min. w/ BL4040, Med.: 150 min. w/ BL4040, Low: 360 min.	w/ BL4040, High: 75 min. w/ BL4040, Med.: 140 min. w/ BL4040, Low: 265 min.
Dimensions (L x W x H)	w/ BL4050F: 1,120 x 223 x 214 mm (44 x 8-3/4 x 8-3/8")	w/ BL4050F: 1,262 x 223 x 214 mm (49-3/4 x 8-3/4 x 8-3/8")
Net weight	4.3 - 4.9 kg (9.5 - 10.8 lbs.)	4.5 - 5.0 kg (9.7 - 11.0 lbs.)

40Vmax XGT BL Brushless Cordless Hedge Trimmer

40V max



	UH020G	UH021G
Blade	Length: 500 mm (19-3/4") Tooth spacing: 30 mm (1-3/16")	Length: 600 mm (23-5/8") Tooth spacing: 30 mm (1-3/16")
No load speed	2,100 min ⁻¹	2,100 min ⁻¹
Max branch diameter	20.0 mm (13/16")	20.0 mm (13/16")
Continuous use (at no load)	110 min.	105 min.
(Battery)	BL4040	BL4040
Dimensions (L x W x H)	929 x 207 x 185 mm (36-1/2 x 8-1/8 x 7-1/4")	1,048 x 207 x 185 mm (41-1/4 x 8-1/8 x 7-1/4")
Net weight	3.0 - 4.2 kg (6.6 - 9.3 lbs.)	3.1 - 4.3 kg (6.8 - 9.5 lbs.)

18V LXT BL Brushless Cordless Hedge Trimmer

18V



Sharp edge curved Blade



	DUH501	DUH601	DUH751
Blade length	500 mm (19-3/4")	600 mm (23-5/8")	750 mm (29-1/2")
Strokes per minute	High / Med. / Low: 0 - 4,400 / 0 - 3,600 / 0 - 2,000 min ⁻¹	High / Med. / Low: 0 - 4,400 / 0 - 3,600 / 0 - 2,000 min ⁻¹	High / Med. / Low: 0 - 4,400 / 0 - 3,600 / 0 - 2,000 min ⁻¹
Tooth spacing	35 mm (1-3/8")	35 mm (1-3/8")	35 mm (1-3/8")
Max cutting capacity	23.5 mm (15/16")	23.5 mm (15/16")	23.5 mm (15/16")
Continuous use	w/ BL1860B, High / Med. / Low: 60 / 80 / 300 min.	w/ BL1860B, High / Med. / Low: 55 / 80 / 200 min.	w/ BL1860B, High / Med. / Low: 45 / 70 / 160 min.
Dimensions (L x W x H)	1,016 x 225 x 192 mm (40 x 8-7/8 x 7-1/2")	1,121 x 225 x 192 mm (44-1/4 x 8-7/8 x 7-1/2")	1,261 x 225 x 192 mm (49-1/2 x 8-7/8 x 7-1/2")
Net weight	3.8 - 4.5 kg (8.4 - 9.8 lbs.)	3.8 - 4.5 kg (8.4 - 9.8 lbs.)	3.8 - 4.5 kg (8.4 - 9.8 lbs.)

18V LXT BL Brushless Cordless Hedge Trimmer

18V



Standard Blade



	DUH502	DUH602	DUH752
Blade length	500 mm (19-5/8")	600 mm (23-5/8")	750 mm (29-1/2")
Strokes per minute	High / Med. / Low: 0 - 4,400 / 0 - 3,600 / 0 - 2,000 min ⁻¹	High / Med. / Low: 0 - 4,400 / 0 - 3,600 / 0 - 2,000 min ⁻¹	High / Med. / Low: 0 - 4,400 / 0 - 3,600 / 0 - 2,000 min ⁻¹
Tooth spacing	35 mm (1-3/8")	35 mm (1-3/8")	35 mm (1-3/8")
Max cutting capacity	21.5 mm (7/8")	21.5 mm (7/8")	21.5 mm (7/8")
Continuous use	w/ BL1860B, High / Med. / Low: 50 / 75 / 230 min.	w/ BL1860B, High / Med. / Low: 45 / 70 / 180 min.	w/ BL1860B, High / Med. / Low: 40 / 60 / 150 min.
Dimensions (L x W x H)	1,016 x 225 x 192 mm (40 x 8-7/8 x 7-1/2")	1,221 x 225 x 192 mm (48-1/8 x 8-7/8 x 7-1/2")	1,261 x 225 x 192 mm (49-1/2 x 8-7/8 x 7-1/2")
Net weight	3.8 - 4.5 kg (8.4 - 9.8 lbs.)	3.8 - 4.5 kg (8.4 - 9.8 lbs.)	3.8 - 4.5 kg (8.4 - 9.8 lbs.)

18V LXT BL Cordless Hedge Trimmer

18V



	DUH506	DUH606
Blade length	500 mm (19-3/4")	600 mm (23-5/8")
Strokes per minute	4,000 min ⁻¹	4,000 min ⁻¹
Tooth spacing	30 mm (1-3/16")	30 mm (1-3/16")
Max branch diameter	20.0 mm (13/16")	20.0 mm (13/16")
Continuous use	w/ BL1860B: 75 min.	w/ BL1860B: 70 min.
Dimensions (L x W x H)	w/ BL1830B / BL1840B / BL1850B / BL1860B: 897 x 207 x 185 mm (35-1/4 x 8-1/8 x 7-1/4")	w/ BL1830B / BL1840B / BL1850B / BL1860B: 1,016 x 207 x 185 mm (40 x 8-1/8 x 7-1/4")
Net weight	2.5 - 2.9 kg (5.5 - 6.4 lbs.)	2.7 - 3.0 kg (6.0 - 6.6 lbs.)

Tree care/Hedge care

18V LXT Cordless Hedge Trimmer

18V



LXT XPT



DUH507

Blade length	500 mm (19-3/4")
Strokes per minute	2,700 min ⁻¹
Tooth spacing	28 mm (1-1/8")
Max branch diameter	15 mm (9/16")
Continuous use	w/ BL1830B: 77 min.
Dimensions (L x W x H)	w/ BL1830B / BL1840B / BL1850B / BL1860B: 925 x 209 x 188 mm (36-1/2 x 8-1/4 x 7-3/8")
Net weight	2.7 - 3.0 kg (6.0 - 6.6 lbs.)

DUH607

Blade length	600 mm (23-5/8")
Strokes per minute	2,700 min ⁻¹
Tooth spacing	28 mm (1-1/8")
Max branch diameter	15 mm (9/16")
Continuous use	w/ BL1830B: 60 min.
Dimensions (L x W x H)	w/ BL1830B / BL1840B / BL1850B / BL1860B: 1,029 x 209 x 188 mm (40-1/2 x 8-1/4 x 7-3/8")
Net weight	2.8 - 3.1 kg (6.2 - 6.8 lbs.)

40Vmax XGT BL Cordless Hedge Trimmer

40V max



XGT BL MOTOR XPT



UH013G

Blade length	600 mm (23-5/8")
Strokes per minute	High / Med. / Low: 5,000 / 3,600 / 2,000 min ⁻¹
Tooth spacing	35 mm (1-3/8")
Max branch diameter	23.5 mm (15/16")
Max cutting capacity	18 mm (11/16")
Continuous use	w/ BL4040, High: 85 min. w/ BL4040, Med.: 160 min. w/ BL4040, Low: 390 min.
Dimensions (L x W x H)	w/ BL4050F: 1,085 x 270 x 168 mm (42-3/4 x 10-5/8 x 6-5/8")
Net weight	3.9 - 4.5 kg (8.6 - 9.9 lbs.)

UH014G

Blade length	750 mm (29-1/2")
Strokes per minute	High / Med. / Low: 5,000 / 3,600 / 2,000 min ⁻¹
Tooth spacing	35 mm (1-3/8")
Max branch diameter	23.5 mm (15/16")
Max cutting capacity	18 mm (11/16")
Continuous use	w/ BL4040, High: 80 min. w/ BL4040, Med.: 155 min. w/ BL4040, Low: 380 min.
Dimensions (L x W x H)	w/ BL4050F: 1,225 x 270 x 168 mm (48-1/4 x 10-5/8 x 6-5/8")
Net weight	4.0 - 4.7 kg (8.8 - 10.4 lbs.)

18V LXT BL Brushless Cordless Hedge Trimmer

18V



LXT BL MOTOR XPT



DUH604S

Blade length	600 mm (23-5/8")
Strokes per minute	High / Med. / Low: 4,400 / 3,600 / 2,000 min ⁻¹
Tooth spacing	35 mm (1-3/8")
Max branch diameter	23.5 mm (15/16")
Continuous use	w/ BL1860B, High / Med. / Low: 70 / 90 / 200 min.
Dimensions (L x W x H)	1,061 x 282 x 143 mm (41-3/4 x 11-1/8 x 5-5/8")
Net weight	3.4 - 3.9 kg (7.5 - 8.6 lbs.)

DUH754S

Blade length	750 mm (29-1/2")
Strokes per minute	High / Med. / Low: 4,400 / 3,600 / 2,000 min ⁻¹
Tooth spacing	35 mm (1-3/8")
Max branch diameter	23.5 mm (15/16")
Continuous use	w/ BL1860B, High / Med. / Low: 65 / 80 / 190 min.
Dimensions (L x W x H)	1,200 x 282 x 143 mm (47-1/4 x 11-1/8 x 5-5/8")
Net weight	3.4 - 3.9 kg (7.5 - 8.6 lbs.)

12Vmax CXT Li-Ion Cordless 20 cm (7-7/8") Hedge Trimmer

12V max



CXT 2in1



UH201D

Blade length	200 mm (7-7/8")
Strokes per minute	2,500 min ⁻¹
Tooth spacing	26 mm (1")
Continuous use	w/ BL1041B / BL1021B / BL1016: 90 / 45 / 35 min.
Dimensions (L x W x H)	504 x 120 x 131 mm (19-7/8 x 4-3/4 x 5-1/8")
Net weight	1.3 - 1.5 kg (2.9 - 3.3 lbs.)

10.8V (12V max) Li-Ion Cordless 20 cm (7-7/8") Hedge Trimmer

10.8V



2in1



UH200D

Blade length	200 mm (7-7/8")
Strokes per minute	2,500 min ⁻¹
Dimensions (L x W x H)	460 x 120 x 130 mm (18-1/8 x 4-3/4 x 5-1/8")
Net weight	1.1 - 1.2 kg (2.5 - 2.6 lbs.)



670 W Hedge Trimmer



	UH5580	UH6580	UH7580
Continuous rating Input	670W	670W	670W
Blade length	550 mm (21-5/8")	650 mm (25-1/2")	750 mm (29-1/2")
Strokes per minute	3,000 min ⁻¹	3,000 min ⁻¹	3,000 min ⁻¹
Dimensions (L x W x H)	970 x 223 x 206 mm (38-1/4 x 8-3/4 x 8-1/8")	1,049 x 223 x 206 mm (41-1/4 x 8-3/4 x 8-1/8")	1,157 x 223 x 206 mm (45-1/2 x 8-3/4 x 8-1/8")
Net weight	4.2 kg (9.2 lbs.)	4.3 kg (9.4 lbs.)	4.4 kg (9.7 lbs.)



550 W Hedge Trimmer



	UH4570	UH5570	UH6570
Continuous rating Input	550W	550W	550W
Blade length	450 mm (17-3/4")	550 mm (21-5/8")	650 mm (25-1/2")
Strokes per minute	3,200 min ⁻¹	3,200 min ⁻¹	3,200 min ⁻¹
Dimensions (L x W x H)	862 x 223 x 206 mm (34 x 8-3/4 x 8-1/8")	970 x 223 x 206 mm (38-1/4 x 8-3/4 x 8-1/8")	1,042 x 223 x 206 mm (41 x 8-3/4 x 8-1/8")
Net weight	3.6 kg (8 lbs.)	3.7 - 3.8 kg (8.2 - 8.4 lbs.)	3.8 - 3.9 kg (8.4 - 8.5 lbs.)



400 W Hedge Trimmer



	UH4261	UH4861	UH5261
Continuous rating Input	400W	400W	400W
Blade length	420 mm (16-1/2")	480 mm (18-7/8")	520 mm (20-1/2")
Strokes per minute	3,200 min ⁻¹	3,200 min ⁻¹	3,200 min ⁻¹
Dimensions (L x W x H)	821 x 194 x 194 mm (32-1/4 x 7-5/8 x 7-5/8")	871 x 194 x 194 mm (34-1/4 x 7-5/8 x 7-5/8")	921 x 194 x 194 mm (36-1/4 x 7-5/8 x 7-5/8")
Net weight	2.9 kg (6.5 lbs.)	3 kg (6.6 lbs.)	3 kg (6.7 lbs.)



Tree care/Hedge care

40Vmax XGT BL Brushless Cordless 60 cm (23-5/8") Pole Hedge Trimmer

UN001G

40V max

Blade length	600 mm (23-5/8")
No load speed	Low: 1,000 min ⁻¹ / Med: 1,500 min ⁻¹ / High: 2,000 min ⁻¹
Cutting strokes per minute	Low: 2,000 min ⁻¹ / Med: 3,000 min ⁻¹ / High: 4,000 min ⁻¹
Tooth spacing	38 mm (1-1/2")
Max cutting diameter	20 mm (13/16")
Dimensions (L x W x H)	2,268 x 100 x 148 mm (89-1/2 x 3-15/16 x 5-7/8")
Net weight	4.7 - 5.9 kg (10.4 - 13.0 lbs.)



18V LXT BL Brushless Cordless 50 cm (19-3/4") Pole Hedge Trimmer, Optimum Curved Blade

DUN500W

18V

Blade length	500 mm (19-3/4")
Strokes per minute	High / Med. / Low: 4,400 / 3,600 / 2,000 min ⁻¹
Tooth spacing	35 mm (1-3/8")
Max cutting capacity	23.5 mm (15/16")
Continuous use	w/ BL1860B, High / Med. / Low: 60 / 90 / 190 min.
Dimensions (L x W x H)	2,115 x 97 x 137 mm (83-1/4 x 3-13/16 x 5-3/8")
Net weight	3.9 - 4.3 kg (8.6 - 9.5 lbs.)



Sharp edge curved Blade

18V LXT BL Brushless Cordless 60 cm (23-5/8") Pole Hedge Trimmer, Optimum Curved Blade

DUN600L

18V

Blade length	600 mm (23-5/8")
Strokes per minute	High / Med. / Low: 4,400 / 3,600 / 2,000 min ⁻¹
Tooth spacing	35 mm (1-3/8")
Max cutting capacity	23.5 mm (15/16")
Continuous use	w/ BL1860B, High / Med. / Low: 55 / 80 / 180 min.
Dimensions (L x W x H)	2,050 x 230 x 178 mm (80-1/2 x 9 x 7")
Net weight	3.7 - 4.1 kg (8.2 - 9.0 lbs.)



Sharp edge curved Blade

18V LXT BL Brushless Cordless 50 cm (19-3/4") Pole Hedge Trimmer

DUN501W

18V

Blade length	500 mm (19-3/4")
Strokes per minute	High / Med. / Low: 4,400 / 3,600 / 2,000 min ⁻¹
Tooth spacing	35 mm (1-3/8")
Max cutting capacity	21.5 mm (7/8")
Continuous use	w/ BL1860B, High / Med. / Low: 55 / 80 / 170 min.
Dimensions (L x W x H)	2,115 x 97 x 137 mm (83-1/4 x 3-13/16 x 5-3/8")
Net weight	3.9 - 4.2 kg (8.6 - 9.3 lbs.)



18V LXT BL Brushless Cordless 60 cm (23-5/8") Pole Hedge Trimmer

DUN601L

18V

Blade length	600 mm (23-5/8")
Strokes per minute	High / Med. / Low: 4,400 / 3,600 / 2,000 min ⁻¹
Tooth spacing	35 mm (1-3/8")
Max cutting capacity	21.5 mm (7/8")
Continuous use	w/ BL1860B, High / Med. / Low: 50 / 70 / 160 min.
Dimensions (L x W x H)	2,050 x 230 x 178 mm (80-1/2 x 9 x 7")
Net weight	3.7 - 4.1 kg (8.2 - 9.0 lbs.)



18V LXT Cordless 46 cm (18-1/8") Pole Hedge Trimmer

DUN461W

18V

Blade length	460 mm (18-1/8")
Strokes per minute	3,600 min ⁻¹
Tooth spacing	28 mm (1-1/8")
Max cutting capacity	18 mm (11/16")
Dimensions (L x W x H)	1,889 - 2,511 x 87 x 134 mm (74-1/2 - 99 x 3-7/16 x 5-1/4")
Net weight	3.0 - 3.3 kg (6.6 - 7.3 lbs.)



12Vmax CXT Cordless 46 cm (18-1/8") Pole Hedge Trimmer

UN460WD

12V max

Blade length	460 mm (18-1/8")
Strokes per minute	3,600 min ⁻¹
Tooth spacing	28 mm (1-1/8")
Max cutting capacity	18 mm (11/16")
Dimensions (L x W x H)	1,889 - 2,511 x 87 x 134 mm (74-1/2 - 99 x 3-7/16 x 5-1/4")
Net weight	2.8 - 3.0 kg (6.2 - 6.6 lbs.)



18V X2 (36V) LXT Li-Ion Battery Powered High Torque Pruning Shears

DUP362

18V x2



Capacity	Max cutting: 33 mm (1-5/16") Max blade opening: 54 mm
Cutting torque	250 N
Dimensions (L x W x H)	305 x 43 x 106 mm (12 x 1-11/16 x 4-3/16")
Net weight	0.77 - 0.82 kg (1.7 - 1.8 lbs.)

LXI XPT



18V X2 (36V) LXT Li-Ion Battery Powered Pruning Shears

DUP361

18V x2



Capacity	Max cutting: 33 mm Max blade opening: 54 mm
Cutting torque	185 N
Dimensions (L x W x H)	305 x 43 x 106 mm (12 x 1-11/16 x 4-3/16")
Net weight	0.8 kg (1.8 lbs.)

LXI XPT



18V LXT BL Battery Powered Pruning Shears

DUP180

18V



Capacity	Max cutting: 30 mm (1-3/16")
Time from fully open to fully closed	0.3 sec
Work amount on a full battery charge	w/ BL1860B: 8,000 pcs
Dimensions (L x W x H)	296 x 40 x 99 mm (11-5/8 x 1-9/16 x 3-7/8")
Net weight	0.67 kg (1.5 lbs.)

LXI BL MOTOR XPT



18V LXT Brushless Cordless Pruning Shears

DUP181

18V



Max cutting capacity	30 mm (1-3/16")
Time from fully open to fully closed	0.34 sec
Work amount on a full battery charge	2,400 pcs
(Battery)	BL1820B
Circumference of grip portion	125 mm (4-7/8")
Dimensions (L x W x H)	300 x 75 x 113 mm (11-3/4 x 2-15/16 x 4-7/16")
Net weight	1.1 - 2.1 kg (2.4 - 4.6 lbs.)

new

LXI BL MOTOR XPT



12Vmax CXT BL Cordless Pruning Shears

UP100D

12V max



Max cutting capacity	25 mm (1")
Time from fully open to fully closed	0.4 sec
Work amount on a full battery charge	w/ BL1021B: 2,200 pcs (when cutting ø15 mm branches of Japanese cypress)
Dimensions (L x W x H)	w/ BL1041B: 308 x 64 x 98 mm (12-1/8 x 2-1/2 x 3-7/8")
Net weight	0.89-1.1 kg (2.0-2.4 lbs.)

CXI BL MOTOR XPT



40Vmax XGT BL Cordless Backpack Mist Blower

PM001G

40V max



No load speed	High: 15,800 - 25,000 min ⁻¹ Med.: 14,700 - 20,700 min ⁻¹ Low: 13,800 - 16,900 min ⁻¹
Solution tank capacity	15.0 L (507 oz)
Air volume	High: 8.6 - 14.3 m ³ /min Med.: 8.0 - 11.0 m ³ /min Low: 7.4 - 9.0 m ³ /min
Max air velocity	High: 39.5 - 64.0 m/s Med.: 36.5 - 52.0 m/s Low: 34.0 - 42.0 m/s
Max horizontal spray range	High: 14.0 m (46 ft)
Dimensions (L x W x H)	w/o Nozzle: 320 x 600 x 690 mm (12-5/8 x 23-5/8 x 27-1/4")
Net weight	13.2 - 15.7 kg (29.1 - 34.6 lbs.)

XGT BL MOTOR XPT



18V LXT Li-Ion Cordless 15 L Garden Sprayer

DUS158

18V



Solution tank	15 L (4.0 US-gal)
Max pressure	0.5 Mpa (5 kgf/cm ²)
Regular water discharge	0.90, 1.70 L/min
(Other conditions)	Double outlet nozzle, Herbicide nozzle
Continuous use (Battery)	335, 460 min. BL1850B
(Other conditions)	Double outlet nozzle, Herbicide nozzle
Hose length	1.7 m (5.6 ft)
Dimensions (L x W x H)	317 x 237 x 517 mm (12-1/2 x 9-3/8 x 20-3/8")
Net weight	5.9 - 6.2 kg (13.0 - 13.7 lbs.)

LXI XPT



18V LXT Li-Ion Cordless 10 L Garden Sprayer

DUS108

18V



Solution tank	10 L (2.6 US-gal)
Max pressure	0.5 Mpa (5 kgf/cm ²)
Regular water discharge	0.90, 1.70 L/min
(Other conditions)	Double outlet nozzle, Herbicide nozzle
Continuous use (Battery)	335, 460 min. BL1850B
(Other conditions)	Double outlet nozzle, Herbicide nozzle
Hose length	1.7 m (5.6 ft)
Dimensions (L x W x H)	317 x 237 x 437 mm (12-1/2 x 9-3/8 x 17-1/4")
Net weight	5.6 - 5.9 kg (12.3 - 13.0 lbs.)

LXI XPT



18V LXT Li-Ion Cordless 5 L Garden Sprayer

DUS054

18V



Solution tank	5 L (1.3 US-gal)
Max pressure	0.3 Mpa (3 kgf/cm ²)
Regular water discharge	Mist, Double outlet: 0.74 L/min
Spraying capacity on a full battery charge	Mist, Double outlet, w/ BL1830B: 170 L Stream, Double outlet, w/ BL1830B: 205 L
Spray wand length	0.5-0.7 m (1.8-2.3 ft)
Hose length	1.7 m (5.6 ft)
Dimensions (L x W x H)	343 x 182 x 368 mm (13-1/2 x 7-1/8 x 14-1/2")
Net weight	3.2 - 3.5 kg (7.1 - 7.7 lbs.)

LXI XPT

12Vmax CXT Li-Ion Cordless 5 L Garden Sprayer

US053D

12V max



Solution tank	5 L (1.3 US-gal)
Max pressure	0.3 Mpa (3 kgf/cm ²)
Regular water discharge	Mist, Double outlet: 0.74 L/min
Spraying capacity on a full battery charge	Mist, Double outlet, w/ BL1016: 60 L Stream, Double outlet, w/ BL1016: 75 L
Spray wand length	0.5-0.7 m (1.8-2.3 ft)
Hose length	1.7 m (5.6 ft)
Dimensions (L x W x H)	343 x 182 x 343 mm (13-1/2 x 7-1/8 x 13-1/2")
Net weight	2.9 - 3.0 kg (6.4 - 6.6 lbs.)

CXI XPT

Transportation

Icon



Variable Speed



Brake



Reversing



Electronic 2-Speed



Electronic 3-Speed



Constant Speed



Soft Start



Built-in Job Light

18V X2 (36V) LXT BL 4-Wheel Battery Powered Wheelbarrow, Electric Lift, 300 Kg Capacity

DCU601

18V x2



Lift height	475 - 1,020 mm (18-3/4 - 40-1/4")
Traveling speed	Forward: 5.0 / 3.5 / 1.5 km/h Reverse: 1.0 km/h
Potential travel distance	w/ BL1860B x4: 7.2 km (4.5 mile)
Continuous use	w/ BL1860B x4: 100 min.
Max climbing capacity	12°
Dimensions (L x W x H) at its smallest:	1,400 x 730 x 820 mm (55 x 28-3/4 x 32-1/4")
Net weight	145 kg (320 lbs.)



Electric lift type

DCU601



18V X2 (36V) LXT BL 4-Wheel Battery Powered Wheelbarrow, Bucket with Electric Dump, 300 Kg Capacity

DCU602

18V x2



Traveling speed	Forward: 5.0 / 3.5 / 1.5 km/h Reverse: 1.0 km/h
Potential travel distance	w/ BL1860B x4: 7.2 km (4.5 mile)
Continuous use	w/ BL1860B x4: 100 min.
Max climbing capacity	12°
Bucket capacity	Heaped capacity: 200 L
Dimensions (L x W x H) at its smallest:	1,480 x 730 x 820 mm (58-1/4 x 28-3/4 x 32-1/4")
Net weight	147 kg (324 lbs.)



Electric dump type

DCU602



18V X2 (36V) LXT BL 4-Wheel Battery Powered Wheelbarrow, Bucket with Manual Dump, 300 Kg Capacity

DCU603

18V x2



Traveling speed	Forward: 5.0 / 3.5 / 1.5 km/h Reverse: 1.0 km/h
Potential travel distance	w/ BL1860B x4: 7.2 km (4.5 mile)
Continuous use	w/ BL1860B x4: 100 min.
Max climbing capacity	12°
Bucket capacity	Heaped capacity: 200 L
Dimensions (L x W x H) When carrier is installed, during operation:	1,480 x 730 x 820 - 1,030 mm (58-1/4 x 28-3/4 x 32-1/4 - 40-1/2")
Net weight	122 - 124 kg (269 - 273 lbs.)



18V X2 (36V) LXT BL 4-Wheel Battery Powered Wheelbarrow, Carrier with Manual Dump, 300 Kg Capacity

DCU604

18V x2



Traveling speed	Forward: 5.0 / 3.5 / 1.5 km/h Reverse: 1.0 km/h
Potential travel distance	w/ BL1860B x4: 7.2 km (4.5 mile)
Continuous use	w/ BL1860B x4: 100 min.
Max climbing capacity	12°
Dimensions (L x W x H) When carrier is installed, during operation:	1,450 - 1,600 x 730 - 1,080 x 820 - 1,030 mm (57 - 63 x 28-3/4 - 42-1/2 x 32-1/4 - 40-1/2")
Net weight	119 - 120 kg (262 - 265 lbs.)



18V X2 (36V) LXT BL 4-Wheel Battery Powered Wheelbarrow, Flat Bucket, 300 Kg Capacity

DCU605

18V x2



Traveling speed	Forward: 5.0 / 3.5 / 1.5 km/h Reverse: 1.0 km/h
Potential travel distance	w/ BL1860B x4: 7.2 km (4.5 mile)
Continuous use	w/ BL1860B x4: 100 min.
Max climbing capacity	12°
Bucket capacity	Full liquid capacity: 250 L
Dimensions (L x W x H) When carrier is installed, during operation:	1,440 x 730 x 820 - 1,030 mm (56-3/4 x 28-3/4 x 32-1/4 - 40-1/2")
Net weight	104 - 106 kg (229 - 234 lbs.)



18V LXT BL 3-Wheel Battery Powered Wheelbarrow, 130 Kg Capacity

DCU180

18V



Traveling speed	Forward, High / Low: 0 - 3.5 / 0 - 1.5 km/h Reverse: 0 - 1 km/h
Max run time	w/ BL1860B x2: 120 min.
Max climbing capacity	12°
Dimensions (L x W x H) When carrier is installed, during operation:	1,315 x 1,060 x 900 mm (51-3/4 x 41-3/4 x 35-1/2")
Net weight	39.3 - 44.8 kg (86.5 - 98.7 lbs.)





Icon

 Carrying Case

12V max CXT Li-Ion Rechargeable Green Multi Line Laser

SK700GD

12V max



Light output power	Less than 2.0 mW
Laser type	Laser class 2: 510 - 530 mm
Number of laser lines	8 (4V4H)
Line width	at 5 m: 2.0 mm
Leveling accuracy	± 2 mm / 10 m
Self-leveling range	± 4°
Operating temperature	-10 - 50°C
Protection class	IP54
Operating time	w/ BL1016: 5
(approx. hours)	w/ BL1021B: 7
	w/ BL1041B: 14
Dimensions (L x W x H)	w/ BL1041B: 168 x 104 x 153 mm
	(6-5/8 x 4-1/8 x 6")
Net weight	0.99-1.2 kg (2.2-2.7 lbs.)

CXI XPT



12V max CXT Li-Ion Rechargeable Red Multi Line Laser

SK700D

12V max



Light output power	Less than 2.0 mW
Laser type	Laser class 2: 630 - 645 mm
Number of laser lines	8 (4V4H)
Line width	at 5 m: 2.0 mm
Leveling accuracy	± 2 mm / 10 m
Self-leveling range	± 4°
Operating temperature	-10 - 50°C
Protection class	IP54
Operating time	w/ BL1016: 8
(approx. hours)	w/ BL1021B: 11
	w/ BL1041B: 22
Dimensions (L x W x H)	w/ BL1041B: 168 x 104 x 153 mm
	(6-5/8 x 4-1/8 x 6")
Net weight	0.99 - 1.2 kg (2.2 - 2.7 lbs.)

CXI XPT



12V max CXT Li-Ion Rechargeable Green Multi Line Laser

SK312GD

12V max



Laser type	Light output power: 1 mW or less
	Safety class: Class 2
	Wavelength: 515 nm
	Line width: 2.5 mm
Lower dot beam	Wavelength: 650 nm
Laser line selection	3V1H
Accuracy 2-vertical line	90 ± 0.01°
Operating time	10 - 28 h
Dimensions (L x W x H)	w/ BL1041B:
	122 x 130 x 225 mm
Net weight	1.5 - 1.6 kg (3.3 - 3.5 lbs.)

CXI XPT



12V max CXT Li-Ion Rechargeable Green Multi Line Laser

SK209GD

12V max



Laser type	Light output power: 1 mW or less
	Safety class: Class 2
	Wavelength: 515 nm
	Line width: 2.5 mm
Lower dot beam	Wavelength: 650 nm
Laser line selection	2V1H
Accuracy 2-vertical line	90 ± 0.01°
Operating time	15 - 40 h
Dimensions (L x W x H)	w/ BL1041B:
	122 x 130 x 225 mm
Net weight	1.5 - 1.6 kg (3.3 - 3.5 lbs.)

CXI XPT



12V max CXT Li-Ion Rechargeable Green Multi Line Laser

SK40GD

12V max



Laser type	Light output power: 5 mW or less
	Safety class: Class 2
	Wavelength: 515 nm
	Line width: 3 mm
Lower dot beam	Wavelength: 650 nm
Laser line selection	4V1H
Accuracy 2-vertical line	90 ± 0.01°
Operating time	6 h
Dimensions (Ø x H)	98 x 223 mm
Net weight	1.4 - 1.6 kg (3.1 - 3.5 lbs.)

CXI XPT



12V max CXT Li-Ion Rechargeable Green Multi Line Laser

SK20GD

12V max



Laser type	Light output power: 5 mW or less
	Safety class: Class 2
	Wavelength: 515 nm
	Line width: 3 mm
Lower dot beam	Wavelength: 650 nm
Laser line selection	2V1H
Accuracy 2-vertical line	90 ± 0.01°
Operating time	9 h
Dimensions (Ø x H)	98 x 223 mm
Net weight	1.4 - 1.6 kg (3.1 - 3.5 lbs.)

CXI XPT



12V max CXT Li-Ion Rechargeable Green Multi Line Laser

SK10GD

12V max



Laser type	Light output power: 5 mW or less
	Safety class: Class 2
	Wavelength: 515 nm
	Line width: 3 mm
Lower dot beam	Wavelength: 650 nm
Laser line selection	1V1H
Accuracy 2-vertical line	90 ± 0.01°
Operating time	12 h
Dimensions (Ø x H)	98 x 223 mm
Net weight	1.4 - 1.6 kg (3.1 - 3.5 lbs.)

CXI XPT



12V max CXT Li-Ion Rechargeable Green 4-Point Cross Line Laser

SK106GD

12V max



Laser type	Laser class 2: 525 mm
Number of laser lines	2 (1V1H)
Number of laser points	4
Laser fan angle	Horizontal: 180° / Vertical: 170°
Measuring range	Up to: 35 m
Measuring range w/ detector	Up to: 80 m
Self-leveling range	± 4°
Leveling accuracy	± 3 mm / 10 m
Operating temperature	-10 - 50°C
Operating time (approx. hours)	7 - 20
Dimensions (L x W x H)	w/ BL1041B: 157 x 64 x 102 mm
	(6-3/16 x 2-1/2 x 4")
Net weight	0.69 - 0.85 kg (1.5 - 1.9 lbs.)

CXI XPT



Measuring/Leveling

12Vmax CXT Li-Ion Rechargeable Red 4-Point Cross Line Laser

SK106D

12V max



Laser type	Laser class 2: 635 mm
Number of laser lines	2 (1V1H)
Number of laser points	4
Laser fan angle	Horizontal: 180° / Vertical: 170°
Measuring range	Up to: 25 m
Measuring range w/ detector	Up to: 80 m
Leveling accuracy	± 3 mm / 10 m
Self-leveling range	± 4°
Operating temperature	-10 - 50°C
Operating time (approx. hours)	15 - 40
Dimensions (L x W x H)	w/ BL1041B: 157 x 64 x 102 mm (6-3/16 x 2-1/2 x 4")
Net weight	0.69 - 0.85 kg (1.5 - 1.9 lbs.)



12Vmax CXT Li-Ion Rechargeable Green Cross Line Laser

SK105GD

12V max



Laser type	Laser class 2: 525 mm
Number of laser lines	2 (1V1H)
Laser fan angle	Horizontal: 180° / Vertical: 160°
Measuring range	Up to: 35 m
Measuring range w/ detector	Up to: 80 m
Leveling accuracy	± 3 mm / 10 m
Self-leveling range	± 4°
Operating temperature	-10 - 50°C
Operating time (approx. hours)	7 - 20
Dimensions (L x W x H)	w/ BL1041B: 157 x 64 x 102 mm (6-3/16 x 2-1/2 x 4")
Net weight	0.67 - 0.84 kg (1.5 - 1.9 lbs.)



12Vmax CXT Li-Ion Rechargeable Red Cross Line Laser

SK105D

12V max



Laser type	Laser class 2: 635 mm
Number of laser lines	2 (1V1H)
Laser fan angle	Horizontal: 180° / Vertical: 160°
Measuring range	Up to: 25 m
Measuring range w/ detector	Up to: 80 m
Leveling accuracy	± 3 mm / 10 m
Self-leveling range	± 4°
Operating temperature	-10 - 50°C
Operating time (approx. hours)	15 - 40
Dimensions (L x W x H)	w/ BL1041B: 157 x 64 x 102 mm (6-3/16 x 2-1/2 x 4")
Net weight	0.67 - 0.84 kg (1.5 - 1.9 lbs.)



12Vmax CXT / 18V LXT / 40Vmax XGT Rechargeable Rotary Laser

SKR001

40V max

18V

12V max



Laser type	Safety class 2 / Wavelength: 520 nm
Operating range	Rotating beam (diameter): 800 m (2,625 ft)
Detection accuracy	Horizontal: ± 0.5 mm / 10 m Vertical: ± 0.75 mm / 10 m
Remote control	Range: 100 m (328.1 ft)
Automatic calibration range	± 5°
Rotation speed	0 / 150 / 300 / 600 min ⁻¹
Scan mode	10 / 20 / 30°
Continuous use (Battery)	71 / 135 / 135 hours
(Other conditions)	BL1050B / BL1860B / BL4040
Dimensions (L x W x H)	At maximum rotation speed 250 x 250 x 309 mm (9-7/8 x 9-7/8 x 12-1/8")
Net weight	4.9 kg (10.8 lbs.)



Automatic Self-Leveling Laser Level

SKR200Z



Laser type	Laser class 2: 620 - 690 nm
Operating range	Rotating beam (diameter): 200 m Plumb beam (up to): 30 m
Rotation speed	0, 300, 450, 600 min ⁻¹
Leveling accuracy	1 mm / 10 m
Leveling range	6°
Operating time (approx. hours)	60
Power supply	Cell battery: 2 pcs
Net weight	1.6 kg (3.5 lbs.)



Laser line



SK700GD

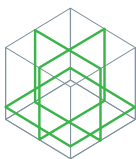

SK700D



SK312GD

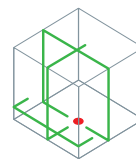

SK209GD

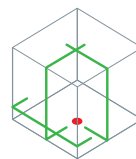

SK40GD

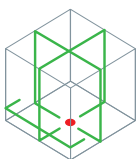

SK20GD

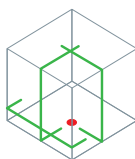

SK10GD

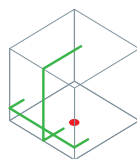

SK106GD

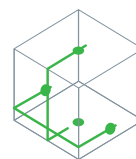

SK106D

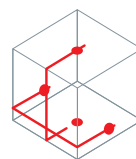

SK105GD



SK105D

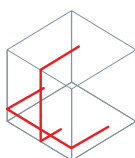

SKR001

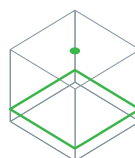

SKR200Z

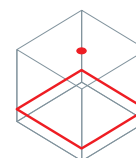

Measuring/Leveling

30 m Laser Distance Measure

LD030P



Laser type	Laser class 2: 635 nm
Measuring range	0.2 - 30 m
Operating temperature	0 - 40°C
Storage temperature	-25 - 70°C
Typical measuring tolerance	2.0 mm / 10 m
Max measuring tolerance	3.0 mm / 10 m
Dimensions (H x D x W)	117 x 53 x 25 mm
Net weight	0.1 kg (0.22 lbs.)

50 m Laser Distance Measure

LD050P



Laser type	Laser class 2: 635 nm
Measuring range	0.05 - 50 m
Power supply	Cell battery: AAA 1.5V x 2 pcs
Net weight	0.1 kg (0.22 lbs.)

80 m Laser Distance Measure

LD080P



Laser type	Laser class 2: 635 nm
Measuring range	0.05 - 80 m
Power supply	Cell battery: AAA 1.5V x 2 pcs
Net weight	0.14 kg (0.31 lbs.)

80 m Laser Distance Measure, Inclination Sensor

LD080PI



Laser type	Laser class 2: 635 nm
Measuring range	0.05 - 80 m
Power supply	Cell battery: AAA 1.5V x 2 pcs
Net weight	0.14 kg (0.31 lbs.)



Lights



Icon



Double Insulation



Soft Start



Carrying Case

Lighting coverage*

*measured in accordance with ANSI

Long-distance irradiation

640m

Spot mode

Front

6.0m

(side: 6.0m)

Front

4.7m

(side: 5.6m)

Front

2.8m

(side: 3.0m)

Front

2.8m

(side: 3.0m)

Front

2.3m

(side: 2.6m)

DML805

ML003G

DML812

ML007G

DML814

DML811

Luminous flux



18V

DML805

750 lm



18V

40V max

ML003G

1,100 lm



18V

DML812

1,250 lm

Spot+Flood mode



40V max

ML007G



18V

DML814



18V

DML811

3,000 lm

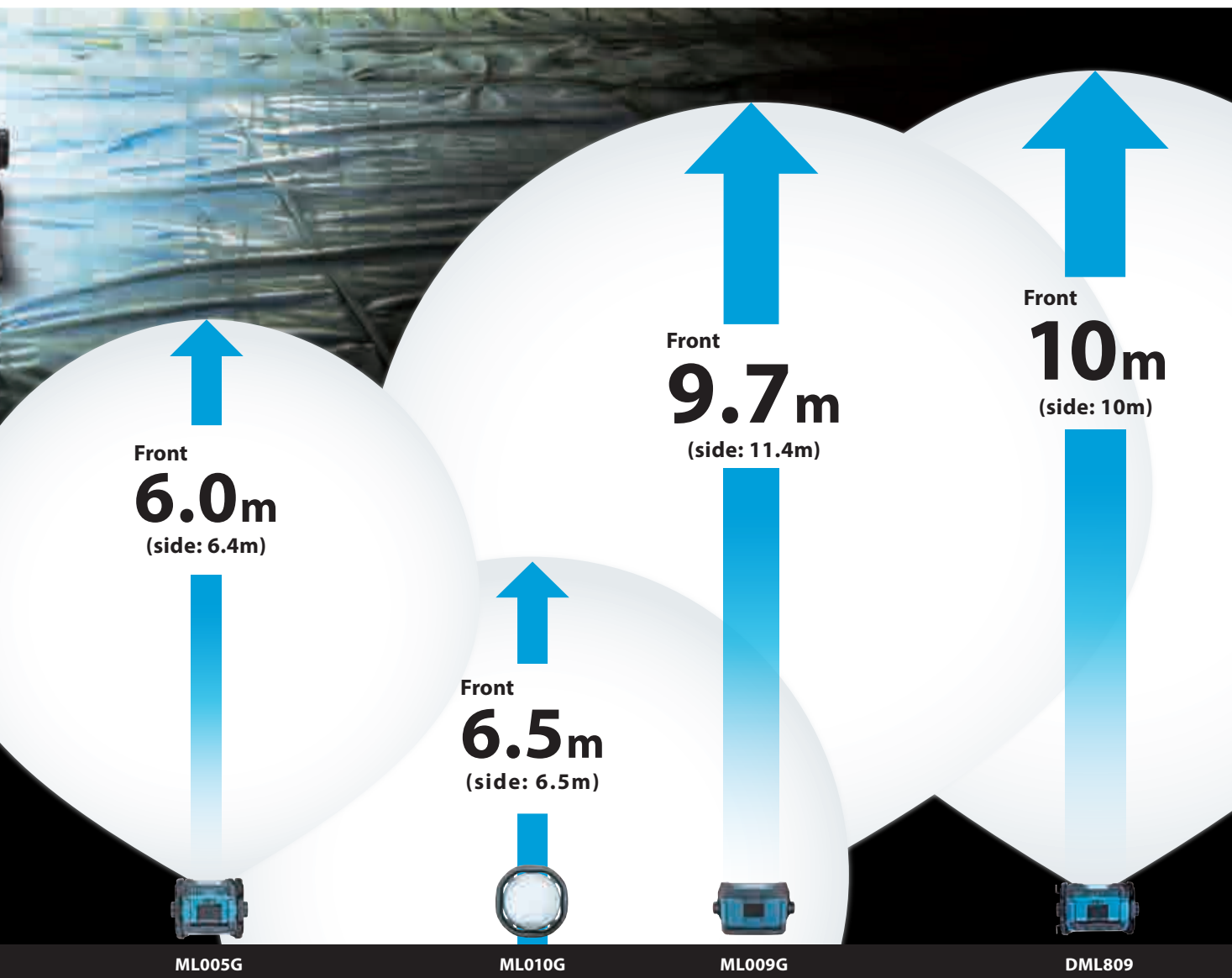

18V 40V max

ML005G
3,600 lm



18V 40V max

ML010G
5,500 lm



18V 40V max





ML009G
10,000 lm







18V

DML809

Product Comparison List



	Cordless Worklight	Cordless Bar Light	Cordless Area Worklight
	DML814  18V Spot lighting / Area lighting	ML012G  40V max	DML818  18V
	ML010G  40V max 18V 		
Run time	w/ BL1850B Low / Mid / High: 10 / 5.5 / 3 hrs	w/ BL4040 Low / Mid / High: 32 / 15 / 7 hrs	w/ BL1860B Low / Mid / High: 23 / 11 / 5 hrs
Illuminance	at 1 m from the light source High / Mid / Low: 1,250 / 750 / 400 lx	at 1 m from the light source High / Mid / Low: 600 / 300 / 100 lx	at 1 m from the light source High / Mid / Low: 600 / 300 / 100 lx
Luminous flux	High / Mid / Low: 3,000 / 1,700 / 900 lm	High / Med. / Low: 1,700 / 800 / 400 lm	High / Med. / Low: 1,700 / 800 / 400 lm
Dimensions (L x W x H)	Operating position (Max height): 573 x 658 x 1,250 - 2,240 mm (22-1/2 x 26 x 49-1/4 - 88")	w/o Battery: 972 x 85 x 100 mm (38-1/4 x 3-3/8 x 3-15/16")	w/o Battery: 972 x 80 x 101 mm (38-1/4 x 3-1/8 x 4")
Net weight	7.4 - 8.1 kg (16.3 - 17.9 lbs.)	2.0 kg (4.4 lbs.)	1.7 kg (3.7 lbs.)





	Cordless Worklight	Cordless Worklight	Cordless Worklight	Cordless Worklight
	ML009G  40V max 18V	ML005G  40V max 18V	ML003G  40V max 18V	DML809  18V 
Run time	w/ BL4080F x2 Low / Mid / High: 28 / 13 / 4.8 hrs	w/ BL4040 Low / Mid / High: 15 / 7.5 / 3.5 hrs	w/ BL4040 Low / High: 22 / 10 hrs	w/ BL1860B x2 Low / Mid / High: 8.5 / 4.5 / 1.7 hrs
Illuminance	at 1 m from the light source High / Mid / Low: 4,300 / 1,900 / 1,000 lx	at 1 m from the light source High / Mid / Low: 2,100 / 1,000 / 500 lx	at 1 m from the light source High / Low: 500 / 200 lx	at 1 m from the light source High / Mid / Low: 3,800 / 1,500 / 800 lx
Luminous flux	High / Mid / Low: 10,000 / 4,000 / 2,000 lm	High / Mid / Low: 3,600 / 1,800 / 900 lm	High / Low: 1,100 / 450 lm	High / Mid / Low: 10,000 / 4,000 / 2,000 lm
Dimensions (L x W x H)	With carrying handle in retracted position: 248 x 386 x 305 mm (9-3/4 x 15-1/4 x 12")	w/ Handle in upright position: 248 x 309 x 423 mm (9-3/4 x 12-1/8 x 16-5/8")	249 x 298 x 280 mm (9-3/4 x 11-3/4 x 11")	w/ Carrying handle in retracted position: 249 x 370 x 278 mm (9-3/4 x 14-1/2 x 11")
Net weight	6.4 - 9.9 kg (14.1 - 21.8 lbs.)	4.9 - 6.5 kg (10.8 - 14.3 lbs.)	4.0 - 4.7 kg (8.8 - 10.4 lbs.)	7.0 kg (15.4 lbs.)

	Cordless Worklight	Corded and Cordless LED Worklight	Cordless Magnetic Light	Cordless Magnetic Light
	DML811  18V 	DML805  18V 	ML013G  40V max 	DML819  18V 
Run time	w/ BL1860B Low / Mid / High: 13 / 7.0 / 3.0 hrs	w/ BL1850B Low / High: 17 / 8.5 hrs	w/ BL4040 Low / Mid / High: 29 / 18 / 12 hrs	w/ BL1860B Low / Mid / High: 22 / 14 / 9 hrs
Illuminance	at 1 m from the light source High / Mid / Low: 1,800 / 800 / 350 lx	at 1 m from the light source High / Low: 300 / 200 lx	at 1 m from the light source High / Mid / Low: 400 / 250 / 150 lx	at 1 m from the light source High / Mid / Low: 400 / 250 / 150 lx
Luminous flux	High / Mid / Low: 3,000 / 1,500 / 750 lm	High / Low: 750 / 450 lm	High / Mid / Low: 1,200 / 800 / 500 lm	High / Mid / Low: 1,200 / 800 / 500 lm
Dimensions (L x W x H)	w/ Handle in retracted position: 249 x 302 x 271 mm (9-3/4 x 11-7/8 x 10-5/8")	214 x 261 x 328 mm (8-3/8 x 10-1/4 x 12-7/8")	w/ BL4040: 196 x 91 x 161 mm (7-3/4 x 3-5/8 x 6-3/8")	w/ BL1830B / BL1840B / BL1850B / BL1860B: 178 x 91 x 161 mm (7 x 3-5/8 x 6-3/8")
Net weight	4.1 - 4.8 kg (9.0 - 10.5 lbs.)	2.3 - 2.7 kg (5.1 - 5.9 lbs.)	1.6 - 2.2 kg (3.5 - 4.9 lbs.)	1.2 - 2.2 kg (2.6 - 4.8 lbs.)

Product Comparison List



	Cordless Flashlight		LED Flashlight	
	ML007G 40V max 	DML812 18V 	ML001G 40V max 	DML802 18V 
Run time	w/ BL4040 Spot mode/ Spot-Flood mode/ Flood mode/ Strobe mode: 10 / 7.5 / 10 / 10 hrs	w/ BL1850B Spot / Flood / Spot-Flood / Strobe: 8.5 / 6.5 / 5.0 / 7.0 hrs	w/ BL4040: 55 hrs	w/ BL1860B: 27 hrs
Illuminance	Spot / Flood / Spot-Flood High / Mid / Low: 82,000 / 520 / 60,000 lx	Spot / Flood / Spot-Flood High / Mid / Low: 71,000 / 520 / 51,000 lx	at 1m from the light source: 3,000 lx	at 1m from the light source: 4,000 lx
Luminous flux	Spot / Flood / Spot-Flood: 600 / 1,000 / 1,250 lm	Spot / Flood / Spot-Flood: 600 / 1,000 / 1,250 lm	160 lm	180 lm
Dimensions (L x W x H)	w/ BL4040: 330 x 120 x 133 mm (13 x 4-3/4 x 5-1/4")	w/ BL1830B / BL1840B / BL1850B / BL1860B: 313 x 119 x 115 mm (12-3/8 x 4-11/16 x 4-1/2")	w/ BL4040: 287 x 88 x 136 mm (11-1/4 x 3-1/2 x 5-3/8")	w/ BL1830B / BL1840B / BL1850B / BL1860B: 272 x 79 x 116 mm (10-3/4 x 3-1/8 x 4-9/16")
Net weight	1.6 - 2.9 kg (3.5 - 6.4 lbs.)	1.2 - 1.6 kg (2.6 - 3.4 lbs.)	0.28 - 1.3 kg (0.62 - 2.9 lbs.)	0.64 - 1 kg (1.4 - 2.2 lbs.)



	Rechargeable Flashlight	Cordless Flashlight
	DML185 18V 	DML808 18V 
Run time	w/ BL1860B: 550 min.	w/ BL1860B: 32 hrs
Illuminance	at 1m from the light source: 4,500 lx	at 1m from the light source: 170 - 4,500 lx
Luminous flux	180 lm	190 lm
Dimensions (L x W x H)	w/o Battery: 284x84x96 mm (11-1/8x3-5/16x3-3/4")	w/ BL1830B / BL1840B / BL1850B / BL1860B: 297 x 79 x 119 mm (11-3/4 x 3-1/8 x 4-11/16")
Net weight	0.71 - 1.03 kg (1.6 - 2.3 lbs.)	0.73 - 1.09 kg (1.6 - 2.4 lbs.)





	Cordless Worklight	Cordless LED Worklight		
	ML002G 40V max USB 	DML807 18V USB 	DML806 18V 	ML104 12V max USB 
Run time	w/ BL4040 Main (Full) / Sub (on top): 16 / 51 hrs	w/ BL1850B Main (Full) / Sub (on top): 11 / 36 hrs	w/ BL1850B Main (Full) / Sub (on top): 11 / 59 hrs	w/ BL1041B Main (Full) / Sub (on top): 5.5 / 19 hrs
Illuminance	Main (Full / Half): 340 / 310 lx / Sub (on top side): 1,900 lx	Main (Full / Half): 340 / 310 lx / Sub (on top side): 1,900 lx	Main (Full / Half): 310 / 280 lx / Sub (on top): 2,100 lx	Main(Full): 340 lx / Sub (on top side): 1,900 lx
Luminous flux	Main(Full / Half): 710 / 340 lm / Sub(on top side): 130 lm	Main(Full / Half): 710 / 340 lm / Sub(on top side): 130 lm	Main(Full / Half): 620 / 310 lm / Sub (on top): 90 lm	Main(Full): 710 lm / Sub(on top side): 130 lm
Dimensions (L x W x H)	w/ BL4040, w/ Hook retracted: 376 x 86 x 141 mm (14-3/4 x 3-3/8 x 5-9/16")	414 x 79 x 155 mm (16-1/4 x 3-1/8 x 6-1/8")	365 x 78 x 119 mm (14-3/8 x 3-1/16 x 4-11/16")	414 x 66 x 132 mm (16-1/4 x 2-5/8 x 5-3/16")
Net weight	1.2 - 1.5 kg (2.6 - 3.3 lbs.)	0.72 - 1.1 kg (1.6 - 2.4 lbs.)	0.69 - 1.1 kg (1.5 - 2.4 lbs.)	0.61 - 0.78 kg (1.4 - 1.7 lbs.)

The weight may differ depending on the attachment(s), including the battery cartridge.

Product Comparison List







	Cordless Flashlight		
	ML006G 40V max 	DML816 18V 	DML801 18V 
Run time	w/ BL4040 Low / Mid / High: 82 / 40 / 20 hrs	w/ BL1860B Low / Mid / High: 75 / 34 / 17 hrs	w/ BL1860B Full / Half: 20 / 48 hrs
Illuminance	at 0.5m from the light source High / Mid / Low: 800 / 400 / 180 lx	at 0.5m from the light source High / Mid / Low: 800 / 400 / 180 lx	at 0.5m from the light source Full / Half: 400 / 200 lx
Luminous flux	High / Mid / Low: 500 / 250 / 100 lm	High / Mid / Low: 500 / 250 / 100 lm	Full / Half: 240 / 120 lm
Dimensions (L x W x H)	w/ BL4025: 402 x 85 x 134 mm (15-3/4 x 3-3/8 x 5-1/4")	w/ BL1830B / BL1840B / BL1850B / BL1860B: 267 - 400 x 79 x 127 mm (10-1/2 - 15-3/4 x 3-1/8 x 5")	380 x 79 x 116 mm (15 x 9-11/16 x 4-9/16")
Net weight	1.1 - 1.7 kg (2.4 - 3.8 lbs.)	0.70 - 1.1 kg (1.5 - 2.4 lbs.)	0.61 - 0.98 kg (1.4 - 2.2 lbs.)

	Rechargeable Flashlight	LED Flashlight
	DML800 18V 	DML803 18V 
Run time	w/ BL1860B: 43 hrs	w/ BL1860B Low / High: 52 / 35 hrs
Illuminance	at 0.5m from the light source: 2,000 lx	at 0.5m from the light source High / Low: 270 / 180 lx
Luminous flux	100 lm	High / Low: 170 / 120 lm
Dimensions (L x W x H)	151 x 76 x 88 mm (5-15/16 x 3 x 3-1/2")	133 x 81 x 72 mm (5-1/4 x 3-3/16 x 2-13/16")
Net weight	0.53 - 0.91 kg (1.2 - 2 lbs.)	0.56 - 0.92 kg (1.2 - 2.1 lbs.)

	Cordless Worklight			Rechargeable LED Lantern
	ML011G 40V max USB 	DML817 18V USB 	ML107 12V max USB 	ML102 10.8V 7.2V 
Run time	w/ BL4040 Full / Half: 37 / 64 hrs	w/ BL1860B Full / Half: 28 / 49 hrs	w/ BL1041B Full / Half: 17 / 29 hrs	w/ BL1013: 8 hrs
Illuminance	at 0.5 m from the light source, Sidelighting + Uplighting / Sidelighting only / Uplighting only: 240 / 190 / 190 lx	at 0.5 m from the light source, Sidelighting + Uplighting / Sidelighting only / Uplighting only: 240 / 190 / 190 lx	at 0.5 m from the light source, Sidelighting + Uplighting / Sidelighting only / Uplighting only: 175 / 130 / 130 lx	-
Luminous flux	Sidelighting + Uplighting / Sidelighting only / Uplighting only: 300 / 150 / 150 lm	Sidelighting + Uplighting / Sidelighting only / Uplighting only: 300 / 150 / 150 lm	Sidelighting + Uplighting / Sidelighting only / Uplighting only: 200 / 100 / 100 lm	-
Dimensions (L x W x H)	w/ BL4020/BL4025: 126 x 77 x 98 mm (5 x 3 x 3-7/8")	w/ BL1830(B)/BL1840(B)/ BL1850(B)/BL1860B: 123 x 77 x 96 mm (4-7/8 x 3 x 3-3/4")	w/ BL1041B: 98 x 64 x 91 mm (3-7/8 x 2-1/2 x 3-5/8")	65 x 65 x 180 mm (2-9/16 x 2-9/16 x 7-1/8")
Net weight	0.88 - 2.1 kg (1.9 - 4.6 lbs.)	0.51 - 0.88 kg (1.1 - 1.9 lbs.)	0.34 - 0.51 kg (0.75 - 1.1 lbs.)	0.32 kg (0.7 lbs.)







Icon

-  Variable Speed
-  Electronic 2-Speed
-  Electronic 3-Speed
-  Electronic 4-Speed
-  Constant Speed
-  Built-in Job Light
-  Carrying Case

Product Comparison List

	Job Site Radio			
	MR007G  40V max 18V 12V max Bluetooth dab+ DC AC	MR006G  40V max 18V 12V max Bluetooth DC AC	MR004G  40V max 18V 12V max Bluetooth dab+ DC AC	MR003G  40V max 18V 12V max dab+ DC AC
Run time	w/ BL4040: 19 hrs / w/ BL1850(B): 17 hrs / w/ BL1041B: 14 hrs	w/ BL4040: 19 hrs / w/ BL1850(B): 17 hrs / w/ BL1041B: 16 hrs	w/ BL4040: 30 hrs / w/ BL1850B: 26 hrs / w/ BL1041B: 21 hrs	w/ BL4040: 34 hrs / w/ BL1850B: 29 hrs / w/ BL1041B: 23.5 hrs
Frequency band	FM / DAB / DAB+: 87.5 - 108 MHz / 174.928 - 239.200 MHz / 174.928 - 239.200 MHz	FM / AM: 87.5 - 108 MHz / 522 - 1,710 kHz	FM / DAB / DAB+: 87.5 - 108 MHz / 174.928 - 239.200 MHz / 174.928 - 239.200 MHz	FM / DAB / DAB+: 87.5 - 108 MHz / 174.928 - 239.200 MHz / 174.928 - 239.200 MHz
Speaker Size	Sides: Dia. 63.5 mm x2 / Bottom: Dia. 101.6 mm	Sides: Dia. 63.5 mm x2 / Bottom: Dia. 101.6 mm	Dia. 89 mm x2	Dia. 89 mm x2
Dimensions (L x W x H)*1	285 x 172 x 441 mm (11-1/4 x 6-3/4 x 17-3/8")	285 x 172 x 441 mm (11-1/4 x 6-3/4 x 17-3/8")	280 x 171 x 434 mm (11 x 6-3/4 x 17-1/8")	280 x 171 x 434 mm (11 x 6-3/4 x 17-1/8")
Net weight	5.5 - 6.3 kg (12.1 - 13.9 lbs.)	5.6 - 6.4 kg (12.3 - 14.1 lbs.)	4.6 - 5.4 kg (10.1 - 11.9 lbs.)	4.6 - 5.4 kg (10.1 - 11.9 lbs.)

*1 with Handle in upright position

	Job Site Radio		Job Site Charger Radio	
	MR002G  40V max 18V 12V max Bluetooth dab+ DC AC	MR001G  40V max 18V 12V max DC AC	DMR301  18V 12V max Bluetooth dab+ DC AC	DMR300  18V 12V max Bluetooth DC AC
Run time	w/ BL4040: 27.5 hrs / w/ BL1850B: 23 hrs / w/ BL1041B: 18.5 hrs	w/ BL4040: 30 hrs / w/ BL1850B: 25.5 hrs / w/ BL1041B: 19.5 hrs	w/ BL1850B: 20.5 hrs / w/ BL1041B: 16.4 hrs	w/ BL1850B: 20.5 hrs / w/ BL1041B: 16.4 hrs
Frequency band	FM / AM: 87.5 - 108 MHz / 522 - 1,710 kHz	FM / AM: 87.5 - 108 MHz / 522 - 1,710 kHz	FM / DAB / DAB+: 87.5 - 108 MHz / 174.928 - 239.200 MHz / 174.928 - 239.200 MHz	FM / AM: 87.5 - 108 MHz / 522 - 1,710 kHz
Speaker Size	Dia. 89 mm x2	Dia. 89 mm x2	Dia. 89 mm x2	Dia. 89 mm x2
Dimensions (L x W x H)*1	280 x 171 x 434 mm (11 x 6-3/4 x 17-1/8")	280 x 171 x 434 mm (11 x 6-3/4 x 17-1/8")	268 x 185 x 427 mm (10-1/2 x 7-1/4 x 16-3/4")	268 x 185 x 427 mm (10-1/2 x 7-1/4 x 16-3/4")
Net weight	4.5 - 5.3 kg (9.9 - 11.7 lbs.)	4.5 - 5.3 kg (9.9 - 11.7 lbs.)	6.1 - 6.6 kg (13.5 - 14.6 lbs.)	6.1 - 6.6 kg (13.5 - 14.6 lbs.)





*1 with Handle in upright position

The weight may differ depending on the attachment(s), including the battery cartridge.



Product Comparison List

	Job Site Radio				Rechargeable Battery Cordless Radio
	DMR115 18V 12V max  Bluetooth DAB+ DC AC	DMR112 18V 12V max 10.8V 7.2V  Bluetooth DAB+ DC AC	DMR116 18V 18V  DC AC	MR052 12V max 	MR051 10.8V 
Run time	w/ BL1850B: 16 hrs / w/ BL1041B: 14 hrs	w/ BL1850B: 26 hrs / w/ BL1041B: 21 hrs / w/ BL1013: 7 hrs / w/ BL0715: 7.5 hrs	w/ BL1850(B): 31 hrs / w/ BL1815G: 10 hrs	w/ BL1041B: 30 hrs	w/ BL1014: 2.5 hrs
Frequency band	FM / DAB / DAB+: 87.5 - 108 MHz / 174.928 - 239.200 MHz / 174.928 - 239.200 MHz	FM / DAB / DAB+: 87.5 - 108 MHz / 174.928 - 239.200 MHz / 174.928 - 239.200 MHz	FM / AM: 87.5 - 108 MHz / 522 - 1,710 kHz	FM / AM: 87.5 - 108 MHz / 522 - 1,710 kHz	FM / AM: 87.5 - 108 MHz / 522 - 1,620 kHz
Speaker Size	Sides: Dia. 63.5 mm x2 / Bottom: Dia. 101.6 mm	Dia. 89 mm x2	Dia. 76 mm x2	-	-
Dimensions (L x W x H)	268 x 164 x 437 mm (10-1/2 x 6-1/2 x 17-1/4")*1	262 x 163 x 431 mm (10-3/8 x 6-3/8 x 17")*1	257 x 163 x 431 mm (10-1/8 x 6-3/8 x 17")*1	w/ BL1016/BL1021B: 169 x 73 x 74 mm (6-5/8 x 2-7/8 x 2-15/16")	169 x 83 x 74 mm (6-5/8 x 3-1/4 x 2-15/16")
Net weight	5.0 - 5.5 kg (11.1 - 12.1 lbs.)	4.3 - 4.9 kg (9.5 - 10.9 lbs.)	4.4 - 4.7 kg (9.7 - 10.4 lbs.)	0.56 - 0.72 kg (1.2 - 1.6 lbs.)	0.49 kg (1.1 lbs.)

*1 with Handle in upright position





	Cordless Radio with Lantern				
	MR010G 40V max  Bluetooth XPT Light tone: 3 tones Brightness: 2 stages	MR009G 40V max  Bluetooth DAB+ XPT Light tone: 3 tones Brightness: 2 stages	DMR057 18V  Bluetooth XPT Light tone: 3 tones Brightness: 2 stages	DMR056 18V  Bluetooth DAB+ XPT Light tone: 3 tones Brightness: 2 stages	DMR055 18V  XPT Light tone: 1 tones Brightness: 1 stages
Run time	[Radio+Lantern(4 side)] BL4040: 15 hrs	[Radio+Lantern(4 side)] BL4040: 14 hrs	[Radio+Lantern(4 side)] BL1850B: 12 hrs	[Radio+Lantern(4 side)] BL1850B: 12 hrs	[Radio+Lantern(4 side)] BL1850B: 12 hrs
Frequency band	FM: 87.5 - 108 MHz	FM: 87.5 - 108 MHz / DAB: 174.928 - 239.200 MHz / DAB+: 174.928 - 239.200 MHz	FM: 87.5 - 108 MHz	FM: 87.5 - 108 MHz / DAB: 174.928 - 239.200 MHz / DAB+: 174.928 - 239.200 MHz	FM: 87.5 - 108 MHz / AM: 522 - 1,710 kHz
Illuminance (lx)	4 sides High/Low*2 3 sides High/Low*2	Daylight white: 145/72 or more, Neutral white: 140/70 or more, Warm white: 130/65 or more			Lantern, Warm white, 4 sides: 130 or more lx
Luminous flux (lm)	4 sides High/Low 3 sides High/Low	Daylight white: 310/155 or more, Neutral white: 300/150 or more, Warm white: 260/130 or more			Lantern, Warm white, 4 sides: 260 or more lm
Dimensions (L x W x H)	w/ BL4020 / BL4025: 126 x 132 x 288 mm (5 x 5-3/16 x 11-3/8")		w/ BL1830B / BL1840B / BL1850B / BL1860B: 126 x 129 x 289 mm (5 x 5-1/8 x 11-3/8")		
Net weight	1.6 - 2.2 kg (3.5 - 4.9 lbs.)		1.3 - 1.6 kg (2.9 - 3.5 lbs.)		1.2 - 1.6 kg (2.7 - 3.5 lbs.)

*2 Illuminance: measured 0.5m in front of the light source

	Cordless Job Site Speaker	
	MR014G 40V max 18V  Qualcomm aptX HD Qualcomm aptX Bluetooth DC AC	DMR203 18V 12V max  Bluetooth DC AC
Run time	[Bluetooth / With the LED decorative line on the front Off] w/ BL4040: 47 hrs / w/ BL1850B: 36 hrs	[Bluetooth] w/ BL1850B: 26 hrs / w/ BL1041B: 22 hrs
Speaker Size	Woofer: Dia. 140.8 mm / Tweeter: Dia. 40 mm / Passive radiator: Dia. 100.7 mm x2	Woofer: Dia. 101.6 mm / Tweeter: Dia. 36 mm / Passive radiator: Dia. 89 mm
Dimensions (L x W x H)*1	243 x 236 x 313 mm (9-9/16 x 9-1/4 x 12-3/8")	217 x 206 x 285 mm (8-1/2 x 8-1/8 x 11-1/4")
Net weight	3.8 kg (8.4 lbs.)	2.7 - 3.4 kg (6.0 - 7.5 lbs.)

*1 with Handle in upright position

Product Comparison List

	Cordless Fan			
	CF003G 40V max 18V 	CF002G 40V max 	DCF301 18V 	CF001G 40V max 
Continuous Use (min.)	w/ BL4080F at max air speed (w/o oscillation): 230 / w/ BL1860B at max air speed (w/o oscillation): 90	w/ BL4040 Low / Mid / High (w/o oscillation): 1,020 / 640 / 320	w/ BL1860B Low / Mid / High (w/o oscillation): 850 / 430 / 215	w/ BL4040 Low / Mid / High (w/o oscillation): 1,160 / 880 / 660
Max air velocity	96 - 300 m/min	High / Mid / Low: 240 / 170 / 120 m/min	High / Mid / Low: 240 / 170 / 120 m/min	High / Mid / Low: 190 / 150 / 120 m/min
Air flow	38 - 120 m ³ /min	High / Mid / Low: 21 / 15 / 10 m ³ /min	High / Mid / Low: 21 / 15 / 10 m ³ /min	High / Mid / Low: 8.2 / 6.5 / 5.2 m ³ /min
Fan diameter	450 mm (17-3/4")	330 mm (13")	330 mm (13")	235 mm (9-1/4")
Automatic oscillation	Left: 30, 45, 60° / Right: 30, 45, 60°	Left: 45° / Right: 45°	Left: 45° / Right: 45°	Left: 45° / Right: 45°
Dimensions (L x W x H)	312 x 633 x 770 mm (12-1/4 x 25 x 30-1/4")	w/ BL4040: 277 x 439 x 602 mm (10-7/8 x 17-1/4 x 23-3/4")	w/ BL1860B: 261 x 439 x 602 mm (10-1/4 x 17-1/4 x 23-3/4")	143 x 333 x 463 mm (5-5/8 x 13 x 18-1/4")
Net weight	7.9 - 10.5 kg (17.4 - 23.1 lbs.)	3.8 - 5.1 kg (8.4 - 11.2 lbs.)	4.5 kg (9.9 lbs.)	2.0 - 3.0 kg (4.4 - 6.6 lbs.)

	Cordless Fan			
	DCF203 18V 	DCF102 18V 	CF101D 12V max 	DCF201 18V 
Continuous Use (min.)	w/ BL1860B Low / Mid / High (w/o oscillation): 1,155 / 700 / 430	w/ BL1860B Low / Mid / High: 1,270 / 705 / 575	w/ BL1041 Low / Mid / High: 630 / 380 / 275	w/ BL1830B Low / High: 200 / 100
Max air velocity	High / Mid / Low: 190 / 150 / 120 m/min	High / Mid / Low: 180 / 150 / 120 m/min	High / Mid / Low: 180 / 150 / 120 m/min	High: 120 m/min
Air flow	High / Mid / Low: 8.2 / 6.5 / 5.2 m ³ /min	High / Mid / Low: 4.6 / 3.8 / 3.0 m ³ /min	High / Mid / Low: 4.6 / 3.8 / 3.0 m ³ /min	-
Fan diameter	235 mm (9-1/4")	180 mm (7-1/8")	180 mm (7-1/8")	250 mm (9-7/8")
Automatic oscillation	Left: 45° / Right: 45°	Left: 45° / Right: 45°	Left: 45° / Right: 45°	-
Dimensions (L x W x H)	140 x 333 x 447 mm (5-1/2 x 13 x 17-5/8")	185 x 272 x 284 mm (7-1/4 x 10-3/10 x 11-1/8")	185 x 260 x 284 mm (7-1/4 x 10-1/4 x 11-1/8")	263 x 330 x 523 mm (10-3/8 x 13 x 20-5/8")
Net weight	1.9 - 2.6 kg (4.2 - 5.6 lbs.)	1.3 - 2.0 kg (2.9 - 4.4 lbs.)	1.7 kg (3.8 lbs.)	2.5 - 2.9 kg (5.5 - 6.3 lbs.)

	Cordless Fan
	CF100D 12V max 
Continuous Use (min.)	w/ BL1041 Low / Mid / High: 630 / 380 / 275
Max air velocity	High / Mid / Low: 180 / 150 / 120 m/min
Air flow	High / Mid / Low: 4.6 / 3.8 / 3.0 m ³ /min
Fan diameter	180 mm (7-1/8")
Automatic oscillation	-
Dimensions (L x W x H)	w/ BL1041B: 168 x 260 x 252 mm (6-5/8 x 10-1/4 x 9-7/8")
Net weight	1.2 - 1.4 kg (2.7 - 3.1 lbs.)

The weight may differ depending on the attachment(s), including the battery cartridge.

Cordless Fan Vest / Cordless Heated Jacket / Cordless Heated Vest

Compatibility table

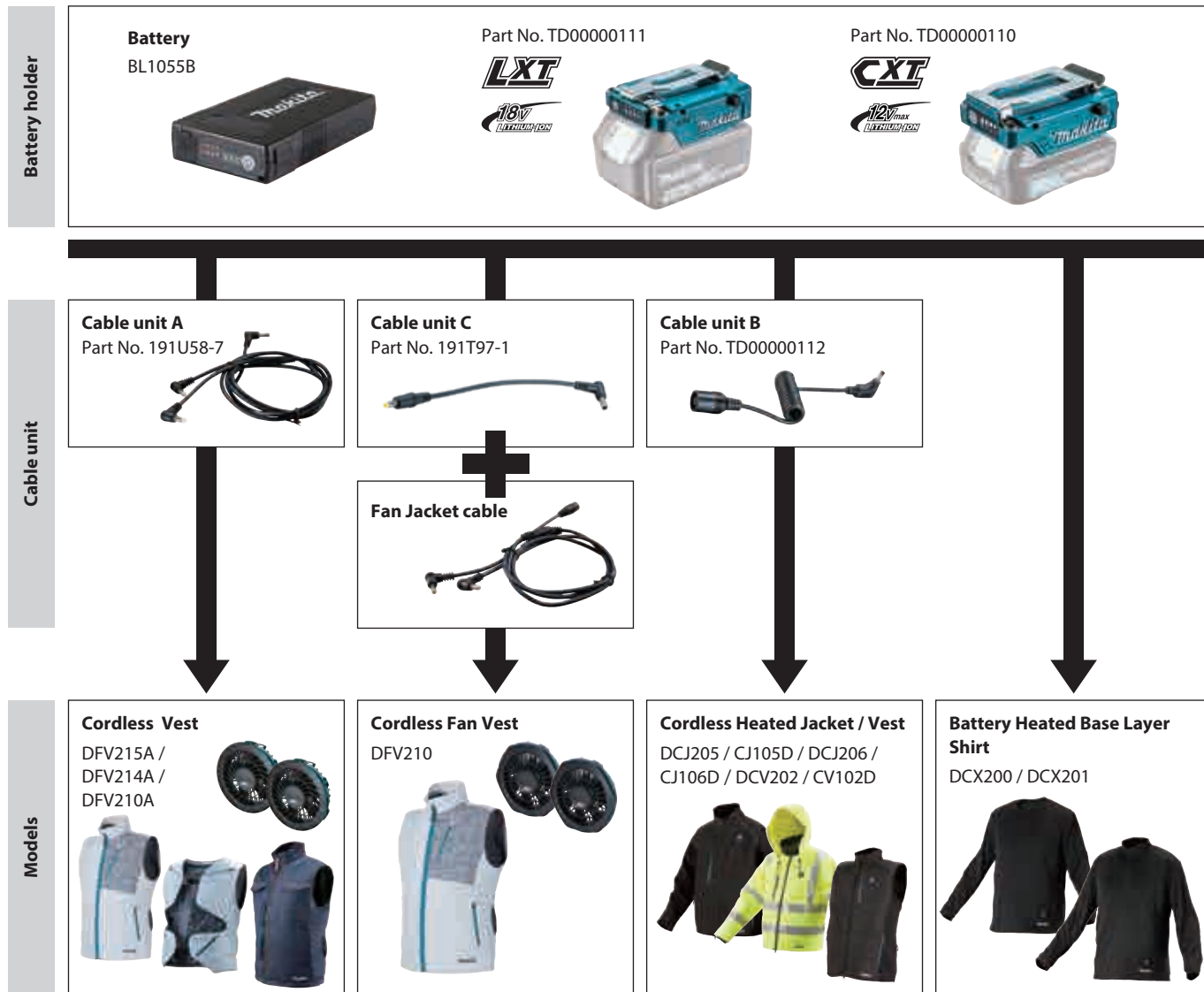

Continuous run time (Cordless Fan Vest) *DFV215A / DFV214A / DFV210A only

Li-ion Battery	model 1	model 2	model 3	model 4	Li-ion Battery	model 1	model 2	model 3	model 4	Li-ion Battery	model 1	model 2	model 3	model 4
18V LXT BL1860B (6.0Ah)	68 h	29.5 h	16 h	10 h	12Vmax CXT BL1041B (4.0Ah)	27.5 h	12 h	6.5 h	4 h	BL1055B (16.75Ah)	40 h	18 h	9.5 h	6 h

Charging Time

Li-ion Battery		DC18RC DC18RD* DC18RE**	DC18SF 1 to 2 batteries / 3 to 4 batteries	DC18SD DC18SH* DC18SE (Automotive)	Li-ion Battery		DC10SB DC18RE**	DC10WD
18V LXT	BL1860B (6.0Ah)	55 min	130 min / 260 min	130 min	12Vmax CXT	BL1050B (5.0Ah)	75 min	160 min
	BL1850B (5.0Ah)	45 min	110 min / 220 min	110 min		BL1041B (4.0Ah)	60 min	130 min
	BL1840B (4.0Ah)	36 min	90 min / 180 min	90 min		BL1021B (2.0Ah)	30 min	70 min
	BL1830B (3.0Ah)	22 min	60 min / 120 min	60 min		BL1016 (1.5Ah)	22 min	50 min
	BL1820B (2.0Ah)	24 min	45 min / 90 min	45 min	Li-ion Battery		AC adapter 5V / 2.4A	
	BL1815N (1.5Ah)	15 min	30 min / 60 min	30 min		BL1055B (16.75Ah)	10 h	

*DC18RD / DC18SH: Two Port Multi Fast Charger **DC18RE: CXT & LXT Dual port Fast Charger

Cordless Fan Vest / Cordless Heated Jacket / Cordless Heated Vest

Jacket Size

Vest

photo: DFV210A



DFV215A	S	M	L	XL	2XL	3XL
Length	63/67	65/69	67/71	69/72	71/73	73/74
Shoulder	39/43	41/45	43/47	45/49	47/51	49/53
Chest	106/113	111/118	116/123	121/128	126/133	131/138
Waist	100/107	105/112	110/117	115/122	120/127	125/132

DFV214A	FA (S~L)	FB (XL~3XL)
Length	49/53	55/57
Shoulder	39/41	42/44
Chest	103~122/110~129	112~131/119~138
Waist	98~117/105~124	107~126/114~133

DFV210A	S	M	L	XL	2XL	3XL
Length	63/67	65/69	67/71	69/72	71/73	73/74
Shoulder	39/43	41/45	43/47	45/49	47/51	49/53
Chest	106/113	111/118	116/123	121/128	126/133	131/138
Waist	100/107	105/112	110/117	115/122	120/127	125/132

Asian Size/EU&US Size (cm)

Jacket Size

Jacket / Base Layer Shirt

photo: DCJ205



Vest

photo: DCV202



DCJ205/CJ105D	S	M	L	XL	2XL	3XL
Length	68	69	71	75	78	82
Shoulder	50.5	52.5	54.5	55.5	56.5	57.5
Sleeve	63	64.5	66	67	68	69
Chest	108	118	128	138	146	156
Waist	102	112	122	132	140	150









DCV202 CV102D	S	M	L	XL	2XL	3XL
Length	72	73	74	75	76	77
Shoulder	47.5	49.5	51.5	53.5	55.5	57.5
Chest	114	120	126	132	138	144
Waist	116	122	128	134	140	146





DCX200 DCX201	EU&US Size						
	XS	S	M	L	XL	2XL	3XL
Length	63	65	68	71	74	77	79
Shoulder	44.5	46.5	48.5	51.5	54.5	57.5	60.5
Sleeve	59	60	61	62	63	64	65
Chest	50	53	56	59	63	67	71
Waist	49	52	55	58	62	66	70

DCX200 DCX201	Asian Size						
	XS	S	M	L	XL	2XL	3XL
Length	61	63	65	68	71	74	77
Shoulder	42.5	44.5	46.5	48.5	51.5	54.5	57.5
Sleeve	58	59	60	61	62	63	64
Chest	47	50	53	56	59	63	67
Waist	46	49	52	55	58	62	66

(cm)

Product Comparison List



	Cordless Inflator			
	MP001G 40V max  XPT 	DMP181 18V  XPT 	DMP180 18V  	MP100D 12V max  
Max air pressure	1,110 kPa (161 PSI) [11.1 bar]	1,110 kPa (161 PSI) [11.1 bar]	830 kPa (121 PSI) [8.3 bar]	830 kPa (121 PSI) [8.3 bar]
Air discharge amount	200 kPa: 24 L/min / 700 kPa: 12 L/min / 1,100 kPa: 7 L/min	200 kPa: 22 L/min / 700 kPa: 11 L/min / 1,100 kPa: 7 L/min	200 kPa: 12 L/min / 700 kPa: 8 L/min / 830 kPa: 7 L/min	200 kPa: 10 L/min
Dimensions (L x W x H)	w/ BL4040: 329 x 108 x 231 mm (13 x 4-1/4 x 9-1/8")	w/ BL1830B / BL1840B / BL1850B / BL1860B: 316 x 108 x 231 mm (12-1/2 x 4-1/4 x 9-1/8")	w/ BL1830B / BL1840B / BL1850B / BL1860B: 266 x 80 x 174 mm (10-1/2 x 3-1/8 x 6-7/8")	w/ BL1041B: 255 x 74 x 173 mm (10 x 2-15/16 x 6-13/16")
Net weight	2.9 - 3.5 kg (6.4 - 7.7 lbs.)	2.5 - 2.8 kg (5.5 - 6.2 lbs.)	1.4 - 1.7 kg (3.1 - 3.8 lbs.)	1.2 - 1.3 kg (2.6 - 3.0 lbs.)

	Cordless Cooler & Warmer Box			
	CW004G 40V max 18V x2  DC AG	CW002G 40V max 18V x2  DC AG	CW003G 40V max 18V x2  DC AG	CW001G 40V max 18V x2  DC AG
Run time	w/ BL1860B x2, -18 / 5 / 60°C: 7.0 / 17.0 / 6.0 hrs w/ BL4050F x2, -18 / 5 / 60°C: 12.5 / 30 / 11.5 hrs	w/ BL4040 x2, -18 / 5 / 60°C: 8 / 19.5 / 4.5 hrs w/ BL4050F x2, -18 / 5 / 60°C: 10 / 24.5 / 6 hrs	w/ BL4040, -18 / 5 / 60°C: 5.5 / 13.5 / 5.5 hrs	w/ BL4050F, -18 / 5 / 60°C: 10 / 28 / 8.5 hrs
Capacity	29 L (7.7 gal)	50 L (13.2 gal)	7 L (1.8 gal)	20 L (5.3 gal)
Temperature setting	-18/-15/-10/-5/0/5/10/15/20/25/30/35/ /40/45/50/55/60°C (0/5/15/25/30/40/50/60/70/75/85/95/ 105/115/120/130/140°F)*	-18/-15/-10/-5/0/5/10/30/35/40/45/ 50/55/60°C (0/5/15/25/30/40/50/85/95/105/115/ 120/130/140°F)	-18/-15/-10/-5/0/5/10/30/35/40/45/ 50/55/60°C (0/5/15/25/30/40/50/85/95/105/115/ 120/130/140°F)	-18/-15/-10/-5/0/5/10/30/35/40/45/ 50/55/60°C (0/5/15/25/30/40/50/85/95/105/115/ 120/130/140°F)
Cord length	AC adapter / Cigar socket cable: 2 / 2.5 m (7.2 / 8.2 ft)	AC adapter / Cigar socket cable: 2 / 2.5 m (6.5 / 8.2 ft)	AC adapter / Cigar socket cable: 2 / 2.5 m (6.5 / 8.2 ft)	AC adapter / Cigar socket cable: 2 / 2.5 m (6.5 / 8.2 ft)
Dimensions (L x W x H)	676 x 345 x 471 mm (26-5/8 x 13-5/8 x 18-1/2")	867 x 465 x 476 mm (34-1/8 x 18-1/4 x 18-3/4")	456 x 245 x 308 mm (18 x 9-5/8 x 12-1/8")	663 x 341 x 372 mm (26-1/8 x 13-3/8 x 14-5/8")
Net weight	17.5 - 20.9 kg (38.6 - 46.1 lbs.)	25.6 - 29.0 kg (56.4 - 63.9 lbs.)	7.9 - 9.4 kg (17.4 - 20.7 lbs.)	13.8 - 17.3 kg (30.4 - 38.1 lbs.)

*Settable max temperature difference between two rooms: 30°C



	Cordless Cooler & Warmer Box
	DCW180 18V x2  DC AG
Run time	w/ BL1860B x2, -18 / 5 / 60°C: 5 / 17 / 4 hrs
Capacity	20 L (5.3 gal)
Temperature setting	-18 / -10 / 0 / 5 / 10/55 / 60°C (0 / 15 / 30 / 40 / 50/130 / 140°F)
Cord length	AC adapter / Cigar socket cable: 2 / 2.5 m (6.5 / 8.2 ft)
Dimensions (L x W x H)	623 x 341 x 371.5 mm (24-1/2 x 13-3/8 x 14-5/8")
Net weight	13.3 - 14.3 kg (29.3 - 32.0 lbs.)

Product Comparison List

	Cordless Kettle	
	KT001G 40V max 	DKT360 18V x2 
Boiling time	8 min (0.8L water from 23 °C)	8 min (0.8L water from 23 °C)
Water tank capacity	800 mL	800 mL
Dimensions (L x W x H)	w/ BL4040: 233 x 322 x 307 mm (9-1/8 x 12-5/8 x 12-1/8")	w/ BL1830B / BL1840B / BL1850B / BL1860B: 233 x 276 x 307 mm (9-1/8 x 10-7/8 x 12-1/8")
Net weight	2.8 - 5.9 kg (6.2 - 13.0 lbs.)	2.7 - 3.4 kg (6.0 - 7.5 lbs.)











	Cordless Coffee Maker
	DCM501 18V 12V max 
Brewing capacity (approx.)	w/ BL1860B: 640 ml / w/ BL1041B: 260 ml
Water tank capacity	240 mL
Compatible cafe pod type	60 mm
Brewing time of 1 cup of coffee	w/ BL1860B: 5 min / w/ BL1041B: 7 min
Dimensions (L x W x H)	w/ BL1830B / BL1840B / BL1850B / BL1860B: 243 x 187 x 218 mm (9-9/16 x 7-3/8 x 8-9/16")
Net weight	1.9 - 2.2 kg (4.1 - 4.8 lbs.)

	Cordless Microwave
	MW001G 40V max 
Capacity	8 L
Output power	High: 500 W / Low: 350 W
Inside dimensions (W x D x H)	255 x 241 x 120 mm (10 x 9-1/2 x 4-3/4")
Dimensions (L x W x H)	w/ BL4040: 372 x 343 x 338 mm (14-5/8 x 13-1/2 x 13-1/4")
weight	9.5 - 12.7 kg (20.9 - 28.0 lbs.)

	Cordless Heated Blanket	
	DCB200 18V 	CB100D 12V max 
Run time (hrs)	w/ BL1860B Low / Mid / High: 35 / 20 / 10	w/ BL1041B Low / Mid / High: 14 / 7.5 / 4
Heat zone	Upper center: 1	Upper center: 1
Dimensions (L x W)	700 x 1,400 mm (27-1/2 x 55")	700 x 1,400 mm (27-1/2 x 55")
Net weight	0.58 kg (1.28 lbs.)	0.58 kg (1.28 lbs.)

Speciality tools

Icon

-  Double Insulation
-  Variable Speed
-  Brake
-  Anti-restart function
-  Electronic 2-Speed
-  Electronic 3-Speed
-  Electronic 4-Speed
-  Constant Speed
-  Built-in Job Light
-  Carrying Case

40Vmax XGT BL Cordless Snow Blower

SN001G

40V max

new



Snow clearing width	530 mm (20-7/8")
Max snow throwing distance	10 m (32.8 ft)
Max snow clearing height	300 mm (11-3/4")
Continuous use (Battery)	20 min.
Work area (Battery)	135 m ²
No load speed	1,400 - 2,100 min ⁻¹
Dimensions (L x W x H)	1,370 x 540 x 975 mm (54 x 21-1/4 x 38-3/8")
Net weight	17.6 - 18.8 kg (38.8 - 41.4 lbs.)



40Vmax XGT BL Cordless Air Compressor

AC001G

40V max



Tank	7.6 L (2 gal)
Max air pressure in tank	0.93 MPa (135 PSI)
Cut-in pressure	0.72 MPa (105 PSI)
No load speed	Crank shaft: 2,075 min ⁻¹
Air flow	at 0.62 MPa (90 PSI): 34 L/min (1.2 SCFM)
Recovery time (from empty to full)	100 sec
Actual nail-driving performance	w/ BL4040: 717 pcs
Dimensions (L x W x H)	w/ European spec tank: 302 x 434 x 382 mm (11-7/8 x 17-1/8 x 15")
Net weight	w/ European spec tank: 11.6 - 12.8 kg (25.6 - 28.2 lbs.)



40Vmax XGT BL Cordless Grease Gun

GP001G

40V max

new



Grease capacity w/ Barrel A	Cartridge / Bulk: 410 / 455 g (14.5 / 16.0 oz)
Flow rate	Mode 1: 145 mL/min (5.0 oz/min) Mode 2: 220 mL/min (7.5 oz/min) Mode 3: 290 mL/min (10.0 oz/min) Mode 4: 350 mL/min (12.0 oz/min)
Max operating pressure	69 MPa (10,000 psi)
Flexible hose length	1,200 mm (47-1/4")
Dimensions (L x W x H)	395 x 112 x 245 mm (15-1/2 x 4-3/8 x 9-5/8")
Net weight	5.2 - 6.5 kg (11.5 - 14.3 lbs.)



18V LXT Li-Ion Cordless Grease Gun

DGP180

18V



Grease capacity w/ Barrel A	Cartridge / Bulk: 410 / 455 g (14.5 / 16.0 oz)
Flow rate	Slow speed mode: 145 mL/min (5.0 oz/min) Auto speed change mode: 290 mL/min (10.0 oz/min)
Max operating pressure	69 MPa (10,000 psi)
Hose length	120 cm (47-1/4")
Dimensions (L x W x H)	w/ Barrel A: 411 x 114 x 245 mm (16-1/4 x 4-1/2 x 9-5/8")
Net weight	4.8 - 6.1 kg (10.6 - 13.4 lbs.)



18V LXT Li-Ion Cordless Vacuum Pump

DVP181

18V



Flow rate	113 L/min
Ultimate vacuum	3 Pa
Motor speed	3,200 min ⁻¹
Oil tank capacity	300 mL
Inlet port	5/16" / 3/8"
Continuous use	w/ BL1860B x2: 60min.
Dimensions (L x W x H)	383 x 193 x 210 mm (15-1/8 x 7-5/8 x 8-1/4")
Net weight	8.1 - 8.2 kg (17.9 - 18.1 lbs.)



18V LXT Li-Ion Cordless Vacuum Pump

DVP180

18V



Flow rate	50 L/min
Ultimate vacuum	20 Pa (150 microns)
Motor speed	3,840 min ⁻¹
Oil tank capacity	115 mL
Inlet port	5/16"
Dimensions (L x W x H)	265 x 93 x 175 mm (10-3/8 x 3-5/8 x 6-7/8")
Net weight	3.5 kg



18V LXT Li-Ion Cordless Caulking Gun

DCG180

18V



Max dispersing force	5,000 N (1,100 lbs)
No load speed	0 - 28 mm/sec. (0 - 66 in/min.)
Holder size	300 / 600 / 800 mL
Dimensions (L x W x H)	404 x 108 x 281 mm (15-7/8 x 4-1/4 x 11-1/8")
Net weight	2.1 - 3 kg (4.7 - 6.6 lbs.)



12V max CXT Li-Ion Cordless Caulking Gun

CG100D

12V max



Max dispersing force	5,000 N (1,100 lbs)
No load speed	0 - 28 mm/sec. (0 - 66 in/min.)
Holder size	300 / 600 / 800 mL
Dimensions (L x W x H)	404 x 108 x 259 mm (15-7/8 x 4-1/4 x 10-1/4")
Net weight	1.9 kg (4.2 lbs.)



4 mm (5/32") 1,100 W Clear Water Submersible Pump

PF1100



Continuous rating Input	1,100W
Suction & discharge diameter	4 mm (5/32")
Max pumping capacity	250 L/min (66 gal/min)
Delivery head max	9 m (30 ft)
Submersion depth	5 m (16 ft)
Min. suction level	25 mm (1")
Grain size inlet	5 mm (1/5")
Dimensions (L x W x H)	150 x 150 x 305 mm (6-5/16 x 7-1/8 x 12")
Net weight	6.7 kg (14.8 lbs.)

4 mm (5/32") 400 W Clear Water Submersible Pump

PF0403



Continuous rating Input	400W
Suction & discharge diameter	4 mm (5/32")
Max pumping capacity	120 L/min (32 gal/min)
Delivery head max	6.5 m (21 ft)
Submersion depth	5 m (16 ft)
Min. suction level	25 mm (1")
Grain size inlet	5 mm (1/5")
Dimensions (L x W x H)	150 x 150 x 260 mm (5-7/8 x 5-7/8 x 10-1/4")
Net weight	4.4 kg (9.7 lbs.)

10 mm (3/8") 800 W Clear Water Submersible Pump

PF0800



Continuous rating Input	800W
Suction & discharge diameter	10 mm (3/8")
Max pumping capacity	220 L/min (58 gal/min)
Delivery head max	9 m (30 ft)
Submersion depth	5 m (16 ft)
Min. suction level	20 mm (4/5")
Grain size inlet	5 mm (1/5")
Dimensions (L x W x H)	160 x 168 x 340 mm (6-5/16 x 6-5/8 x 13-3/8")
Net weight	6.1 kg (13.5 lbs.)

8 mm (5/16") 300 W Clear Water Submersible Pump

PF0300



Continuous rating Input	300W
Suction & discharge diameter	8 mm (5/16")
Max pumping capacity	140 L/min (37 gal/min)
Delivery head max	7 m (23 ft)
Submersion depth	5 m (16 ft)
Min. suction level	20 mm (4/5")
Grain size inlet	5 mm (1/5")
Dimensions (L x W x H)	160 x 168 x 305 mm (6-5/16 x 6-5/8 x 12")
Net weight	4.2 kg (9.3 lbs.)

40 mm (1-9/16") 1,100 W Dirty Water Submersible Pump

PF1110



Continuous rating Input	1,100W
Suction & discharge diameter	40 mm (1-9/16")
Max pumping capacity	250 L/min (66 gal/min)
Delivery head max	10 m (33 ft)
Submersion depth	5 m (16 ft)
Min. suction level	50 mm (2")
Grain size inlet	35 mm (1-3/8")
Dimensions (L x W x H)	160 x 185 x 355 mm (6-5/16 x 7-1/4 x 14")
Net weight	7 kg (15.4 lbs.)

30 mm (1-3/16") 1,100 W Dirty Water Submersible Pump

PF1010



Continuous rating Input	1,100W
Suction & discharge diameter	30 mm (1-3/16")
Max pumping capacity	240 L/min (63 gal/min)
Delivery head max	10 m (33 ft)
Submersion depth	5 m (16 ft)
Min. suction level	40 mm (1-4/7")
Grain size inlet	35 mm (1-3/8")
Dimensions (L x W x H)	160 x 168 x 380 mm (6-5/16 x 6-5/8 x 15")
Net weight	6.6 kg (14.6 lbs.)

40 mm (1-9/16") 550 W Dirty Water Submersible Pump

PF0610



Continuous rating Input	550W
Suction & discharge diameter	40 mm (1-9/16")
Max pumping capacity	180 L/min (48 gal/min)
Delivery head max	7 m (23 ft)
Submersion depth	5 m (16 ft)
Min. suction level	50 mm (2")
Grain size inlet	35 mm (1-3/8")
Dimensions (L x W x H)	160 x 185 x 335 mm (6-5/16 x 7-1/4 x 13-1/4")
Net weight	5.5 kg (12.3 lbs.)

25 mm (1") 400 W Dirty Water Submersible Pump

PF0410



Continuous rating Input	400W
Suction & discharge diameter	25 mm (1")
Max pumping capacity	140 L/min (37 gal/min)
Delivery head max	5 m (16 ft)
Submersion depth	5 m (16 ft)
Min. suction level	40 mm (1-4/7")
Grain size inlet	35 mm (1-3/8")
Dimensions (L x W x H)	160 x 168 x 345 mm (6-5/16 x 6-5/8 x 13-5/8")
Net weight	4.3 kg (9.5 lbs.)



Speciality tools

40Vmax XGT Cordless Heat Gun

HG001G

40V max

new



Air temperature	Ambient temperature (blowing) - 600 °C (1,112.0 °F)
Air volume	120 / 150 / 180 / 200 L/min
Continuous use	14 min.
(Battery)	BL4040
(Other conditions)	600°C, 200 L/min
Dimensions (L x W x H)	191 x 86 x 272 mm (7-1/2 x 3-3/8 x 10-3/4")
Net weight	1.5 - 2.7 kg (3.3 - 6.0 lbs.)

XGT



18V LXT Cordless Heat Gun

DHG181

18V



Air temperature	Ambient temperature (blowing) - 550 °C (1,022.0 °F)
Air volume	70 / 110 L/min
Continuous use	23 min.
(Battery)	BL1860B
Nozzle mounting port diameter	34.5 mm (1-3/8")
Dimensions (L x W x H)	175 x 76 x 253 mm (6-7/8 x 3 x 10")
Net weight	1.2 kg (2.6 lbs.)

LXT



18V LXT Cordless Heat Gun

DHG180

18V



Air temperature	550 °C (1,022.0 °F)
Air volume	110 L/min
Continuous use	23 min.
(Battery)	BL1860B
Nozzle mounting port diameter	34.5 mm (1-3/8")
Dimensions (L x W x H)	165 x 76 x 248 mm (6-1/2 x 3 x 9-3/4")
Net weight	1.0 - 1.3 kg (2.2 - 2.9 lbs.)

LXT



2,000 W Heat Gun

HG6530V



Continuous rating Input	2,000W
Air temperature	50 - 650 °C
Air flow	Stage 1: 500 L/min Stage 2: 280 L/min Stage 3: 550 L/min
Dimensions (L x W x H)	257 x 85 x 206 mm (10-1/8 x 3-3/8 x 8-1/8")
Net weight	0.72 kg (1.6 lbs.)



2,000 W Heat Gun

HG6531C



Continuous rating Input	2,000W
Air temperature	50 - 650 °C
Air flow	200 - 550 L/min
Dimensions (L x W x H)	257 x 85 x 206 mm (10-1/8 x 3-3/8 x 8-1/8")
Net weight	0.71 kg (1.6 lbs.)



1,800 W Heat Gun

HG6030



Continuous rating Input	1,800W
Air temperature	Stage 1: 50 °C Stage 2: 300 °C Stage 3: 600 °C
Air flow	Stage 1: 250 L/min Stage 2: 250 L/min Stage 3: 500 L/min
Dimensions (L x W x H)	233 x 80 x 208 mm (9-1/8 x 3-1/8 x 8-3/16")
Net weight	0.57 kg (1.3 lbs.)



1,800 W Heat Gun

HG6031V



Continuous rating Input	1,800W
Air temperature	Stage 1: 50-400 °C Stage 2: 100-600 °C
Air flow	Stage 1: 250 L/min Stage 2: 500 L/min
Dimensions (L x W x H)	257 x 85 x 206 mm (10-1/8 x 3-3/8 x 8-1/8")
Net weight	0.67 kg (1.5 lbs.)



1,600 W Heat Gun

HG5030



Continuous rating Input	1,600W
Air temperature	Stage 1: 350 °C Stage 2: 500 °C
Air flow	Stage 1: 300 L/min Stage 2: 500 L/min
Dimensions (L x W x H)	233 x 80 x 208 mm (9-1/8 x 3-1/8 x 8-3/16")
Net weight	0.56 kg (1.2 lbs.)





Communication connector designed to enable communication between XGT tool/battery and mobile device/PC

Dimensions (L x W x H) 98 x 85 x 55 mm
(3-7/8 x 3-3/8 x 2-3/16")
Net weight 0.17 kg (0.38 lbs.)

ADP12

40V max



Communication connector designed to enable communication between XGT tool/battery and mobile device/PC

Dimensions (L x W x H) 98 x 85 x 55 mm
(3-7/8 x 3-3/8 x 2-3/16")
Net weight 0.17 kg (0.38 lbs.)

ADP13

40V max



Charges mobile devices e.g. smartphones, tablets and more, and developed as XGT version of ADP05

Dimensions (L x W x H) w/ BL4020 / BL4025:
119 x 79 x 88 mm
(4-11/16 x 3-1/8 x 3-1/2")
w/ BL4040: 133 x 83 x 94 mm
(5-1/4 x 3-1/4 x 3-11/16")
w/ BL4050F: 153 x 79 x 114 mm
(6 x 3-1/8 x 4-1/2")
Net weight 0.14 kg (0.31 lbs.)

ADP001G

40V max



AA battery pack designed to supply power to the machines (compatible with only some models such as green multi line lasers) powered by 12Vmax CXT Li-ion battery

ADP09



Li-ion 14.4/18V batteries can charge smartphones and operate laser levels. Slide style Li-ion battery 18V/14.4V (except the Light Battery series)

ADP05

18V



Dimensions (L x W x H) w/o Battery: 102 x 72 x 43 mm
(4 x 2-13/16 x 1-11/16")
Net weight w/o Battery: 0.11 kg (0.24 lbs.)

Slide style 10.8V batteries can charge smartphones and USB devices.

ADP06

12V max



Dimensions (L x W x H) w/o Battery: 80 x 53 x 38 mm
(3-1/8 x 2-1/16 x 1-1/2")
Net weight w/o Battery: 0.07 kg (0.15 lbs.)

Charges mobile devices e.g. smartphones, tablets and more

ADP08

12V max



Dimensions (L x W x H) w/o Battery: 80 x 53 x 28 mm
(3-1/8 x 2-1/16 x 1-1/8")
Net weight : 0.06 kg (0.13 lbs.)

Car cigarette lighter adapter supporting USB PD up to 65W

ADP14

new



Dimensions (L x W x H) 37 x 37 x 86 mm
(1-7/16 x 1-7/16 x 3-3/8")
Net weight 0.04 kg (0.09 lbs.)

Accessory Index

<p>p.197</p> <p>Screwing/ Drilling</p>	<p>Drill chuck assembly for impact driver</p> 	<p>Angle attachment</p> 	<p>Straight head</p> 	<p>Autofeed attachment</p> 	<p>Locator</p> 		
<p>p.199</p> <p>Hammer drilling/ chiselling</p>	<p>Drill chuck assembly</p> 	<p>Dust extraction system set</p> 	<p>Filter</p> 	<p>Hammer carrier</p> 	<p>Grease vessel</p> 		
<p>p.201</p> <p>Grinding/ Sanding/ Polishing</p>	<p>Rubber pad</p> 	<p>Wheel guard</p> 	<p>Inner flange & Lock nut</p> 	<p>Grip</p> 	<p>Collet cone/ Collet nut</p> 	<p>Punch plate</p> 	
<p>p.205</p> <p>Cutting</p>	<p>Tilt base</p> 	<p>Cover set</p> 	<p>Cutting wax</p> 	<p>Threaded rod cutter blade</p> 	<p>Punch/ Die</p> 	<p>Crimper</p> 	
<p>p.207</p> <p>Sawing</p>	<p>Crown molding stopper</p> 	<p>Extension table</p> 	<p>Stand</p> 	<p>Guide rail</p> 	<p>Guide Rail Adaptor</p> 		
<p>p.211</p> <p>Milling/ Planing</p>	<p>Collet corn/ Collet nut</p> 	<p>Straight guide assembly</p> 	<p>Trimmer base</p> 	<p>Templet guide</p> 	<p>Drywall guide bit</p> 		
<p>p.212</p> <p>Fastening/ Fixing</p>	<p>Rivet gun maintenance kit</p> 	<p>Tie wire set</p> 	<p>Nails & Staples</p> 	<p>Coil tape collated screws</p> 	<p>Flat Tape Collated Screws</p> 		
<p>p.218</p> <p>Cleaning</p>	<p>Vacuum Cleaner System charts for Dust Collecting</p> 	<p>Vacuum Cleaner System charts for Cleaning</p> 	<p>Filter & Dust bag</p> 	<p>Cordless Cleaner System charts</p> 	<p>Selectable filters</p> 	<p>Hose, Front cuffs & Joint</p> 	<p>Dust Blower accessories</p> 
<p>p.234</p> <p>OPE</p>	<p>Brushcutter blades</p> 	<p>Nylon cutting head</p> 	<p>Chain blade Guide Bar</p> 	<p>Shear blade</p> 	<p>Wheelbarrow attachment</p> 	<p>Robotic mower accessories</p> 	
<p>p.249</p> <p>Others</p>	<p>Worklight accessories</p> 	<p>Grease Gun accessories</p> 	<p>Heat Gun accessories</p> 	<p>Hook</p> 	<p>Battery adapter & battery converter</p> 		

Drill chuck assembly for impact driver

Still photo	Name	Related models	Connection size mm (inch)	Max diameter of compatible bit mm	Type	Part No.	
	Drill chuck S10 & key set	TD0100, TD0101, TD0101F	HEX. 6.35 (1/4)	10	48-NZ	191880-6	
	Drill chuck set	DF030D, TD0100, TD0101, TD0101F, TD090D, TD091D, TD111D				198913-8	
	Keyless drill chuck set	DTP141, TD0100			44-MZ	194250-8	
		DTP141, TD0100, TD0101, TD0101F				194251-6	
		DTP141, TD0100, TD0101, TD0101F, TD127D			-	48-NZ	192121-3
		TD0100			10	44-MZ	192077-0

Drill stand



Name	Related models	Part No.
Drill stand set	DDF458, DDF486, DF003G, DHP458, DHP486, HP003G	1917P9-8

Angle attachment

Still photo	Name	Related models	No load speed high rpm	No load speed low rpm	Part No.
	Angle attachment set	DA4000LR	900	400	193316-1

Extension attachment

Still photo	Name	Related models	Part No.
	Extension attachment set	DA4000LR	193317-9

Head for driver

Still photo	Name	Related models	Type	Part No.
	Straight attachment	DTL061, DTL063, TL064D, TL065D	NZ	192440-7
	Straight attachment set		FOR E-FORM BIT MZ	192486-3

Ratchet head adapter

Still photo	Name	Related models	Connection type	Connection size mm (inch)	Type	Part No.
	Ratchet attachment set	DTL061, DTL063, TL064D, TL065D	-	-	HEX. 21MM	192439-2
	Socket adapter 6.35 set	DWR180, WR100D	SQUARE DRIVE	6.35 (1/4)	HEX. 13MM - SQ-DRIVE	191A51-1
	Socket adapter 9.5 set			9.5 (3/8)	HEX. 13MM - SQ-DRIVE	191A50-3

Adjustable locator for impact driver

Still photo	Name	Related models	Part No.
	Stopper set	6952, DTD152, DTD153, DTD157	194633-2
		DTD152, DTD153, DTD157, TD0100, TD0101, TD0101F, TD111D	194280-9
			194281-7

Autofeed attachment set

Still photo	Name	Related models	Part No.
	Autofeed attachment set	DFS250, DFS452, FS2200, FS2300, FS4000, FS4200, FS4300, FS6200, FS6300, FS6300R	191L23-2
			191L24-0
		DFS250, DFS452, FS2200, FS4000, FS4200, FS6200, FS6300	191L25-8

Casing for auto feed screwdriver

Still photo	Name	Related models	Screw length mm	Part No.
	Casing 41 set	DFR452	25-41	1915G8-5
		DFR550		191B45-2
	Casing 55 set	DFR551	25-55	1915G9-3

Bit for autofeed attachment set



Name	Related models	Bit type	Length mm	Part No.
Bit 2-130 set	DFS250, DFS452, FS2200, FS4000, FS4200, FS6200, FS6300	PH2	130	199409-2
Bit 2-137 set	DFR452, DFR453		137	191V01-2
Bit 2-155 set	DFR551, DFR552		155	191V02-0
Phillips bit 2-130 set	DFS452		130	199155-7
Pozidrive bit 2-137 set	DFR452	PZ2	137	191V05-4
Pozidrive bit 2-155 set	DFR551		155	191V06-2
Square bit 2-130 set	DFS250, DFS452, FS2200, FS2300, FS4000, FS4200, FS4300, FS6200, FS6300, FS6300R	SQ2	130	199156-5
	DFS250, DFS452, FS2200, FS4000, FS4200, FS6200, FS6300			199410-7
Square bit 2-137 set	DFR452		137	191V03-8
Square bit 2-155 set	DFR551		155	191V04-6

Screwing/ Drilling

Shear wrench sleeve

For Model 6922NB, DWT310, WT001G

*Type F (for HEXA TECH (GFD France))

** for Chinese market



Bolt Size	Outer sleeve			Inner sleeve	
	Hex size	L (mm)	Part No.	L (mm)	Part No.
M16	27	35	764362-7	36	764416-0 *764421-7
		81	764367-7	82	764356-2
		100	764406-3	100	764400-5
		200	764407-1	200	764401-3
M20	32	37	764361-9 **196276-6	38	764417-8 *764422-5
		83	764363-5	84	764357-0
		100	764408-9	100	764402-1
		200	764409-7	200	764403-9
M22, 7/8"	36 1-7/16"	39	153909-6	39	764418-6 *764423-3
		85	764364-3	85	764352-0
		100	764410-2	100	764404-7
		170	764365-1	170	764354-6
3/4"	1-1/4"	200	764411-0	200	764405-5
		37	764361-9	38	764419-4
		83	764363-5	84	764353-8
5/8"	1-1/16"	168	764366-9	169	764355-4
		35	764362-7	36	764420-9

For Model 6924N

Bolt Size	Outer sleeve			Inner sleeve	
	Hex size	L (mm)	Part No.	L (mm)	Part No.
M22	36	49	194033-6	48	194310-6
M24	41		194034-4	49	194311-4
7/8"	1-7/16"		194092-0	48	194310-6
1"	1-5/8"		194034-4	49	194312-2

SDS-MAX drill bit remover set

Still photo	Name	Related models	Connection type	Connection size mm (inch)	Part No.
	Drill bit remover set	6905H, DTW450, TW0350	SQUARE DRIVE	12.7 (1/2)	195870-1 195871-9

Bit adapter for screwing, drilling

Still photo	Name	Related models	Connection type	Connection size mm (inch)	Type	Part No.
	Bit adapter set	6953, DTW251, TW0200	SQUARE DRIVE	12.7 (1/2)	TO E-FORM (MZ)	191B20-8

Extension handle

Still photo	Name	Related models	Part No.
	Extension handle set	DTW1001, DTW1002, DTW1004, DTW700, DTW701, DTW800, TW001G, TW002G, TW003G, TW007G, TW008G	191G67-2

Anti kick back head

Still photo	Name	Related models	Connection type	Type	Part No.
	Anti kick back head M set	DFT043F, DFT083F, DFT125F	E-FORM MZ	MZ	195231-5
	Anti kick back head N set		E-FORM NZ	NZ	195232-3
	Anti kick back head set	DFL083F	-	-	199065-8
		DFL651F	-	-	197045-8

Torque tracer accessory



Name	Related models	Type	Part No.
Receiver set RCV02	DFL301R	-	196962-9
	DFL301R, DFL402R, DFT041R, DFT082R, DFT124R	RCV02	194444-5 194480-1

Side grip for drill and angle drill

Still photo	Name	Related models	Part No.
	Grip assembly set	DDF489	1912A3-5
		DHP489	1912A4-3
	Grip set	DA001G, DA002G	191R81-4
	Handle set	DDG461, DG002G	191P11-3
	Side handle set	DP4020, DP4021	1914C4-9

Rubber pad for drill

Still photo	Name	Related models	Part No.
	Rubber pad assembly set	DDF451	1914R2-8

Drill chuck assembly

Still photo	Name	Related models	Connection type	Part No.
	Drill chuck set	HR2230, HR2475, HR2631F, HR2652, HR2670, HR2810	SDS-PLUS	194041-7

Quick change drill chuck set

Still photo	Name	Related models	Connection type	Part No.
	Drill chuck set	DHR243, DHR264, HR2320T, HR2631F, HR2631FT, HR2653T, HR2810T, HR2811FT	-	194079-2
		DHR281, DHR283		199139-5
		HR009G, HR012G, HR2670FT, HR3012FC		191F46-4
		HR3210FCT		194568-7
	Tool holder set	DHR281, DHR283	SDS-PLUS	199138-7
		HR009G, HR012G, HR3012FC		191F47-2
		HR3210FCT		194578-4

Spacer set

Still photo	Name	Related models	Part No.
	Spacer set	HR008G, HR3001C, HR3011FC	191L91-5

Dust extraction system set





Name	Related models
DX06	DHR242
DX07	DHR243
DX08	DHR280, DHR282
DX09	DHR281, DHR283
DX10	HR008G, HR3011FC
DX11	HR009G, HR3012FC
DX12	HR001G, HR003G
DX14	HR002G, HR004G
DX15	HR007G
DX16	HR010G, DHR183
DX17	HR011G
DX18	HR012G

Dust case for dust extraction system





Still photo	Name	Related models	For	Capacity ml	Part No.
	Dust case set	DHR183, HR010G	DX16	400	1911P4-2
		DHR242, DHR243	DX06, DX07	300	199977-5
		HR008G, HR009G, HR3011FC, HR3012FC	DX10, DX11	550	191F49-8
		HR008G, HR3011FC	DX10		191F50-3
		HR011G	DX17	-	1916C1-7
		HR011G, HR012G	DX18	-	1916C0-9

Filter for dust extraction system





Still photo	Name	Related models	Part No.
	Filter set	DHR242, DHR243, DHR280, DHR281, DHR282, DHR283, HR007G, HR008G, HR009G, HR2652, HR2653, HR2653T, HR2663, HR3011FC, HR3012FC	199557-7
		HR011G, HR012G	199596-7

Depth gauge for hammer drills

Still photo	Name	Related models	Part No.
	Depth gauge set	DD2020	196856-8
		DP2010, DP2011	196322-5

Hammer drilling/ chiselling

Side grip, handle for hammer drills



Still photo	Name	Related models	Part No.
	Grip assembly set	DDF484, DF002G, DHP484, HP002G	191E41-8
	Grip base set	HR1841F	194581-5
		HR2230	194583-1
	Side handle 73 set	HR005G, HR4003C, HR4013C	196792-8

Hammer carrier



Name	Related models	Part No.
HAMMER CARRIER	HM004G	JM00000674

Hammer bit grease

Still photo	Name	Related models	Capacity ml (g)	Part No.
	Grease vessel set	All Rotary hammer, Demolition hammer, Electric breaker, Scraper	100	198993-4 194683-7 198174-0
		HK0500, HR3200C, HR3210C, HR3210FCT, HR3540C, HR3541FC	95	196804-7
		HK0500, HR166D, HR3200C, HR3210C, HR3210FCT, HR3540C, HR3541FC	(30)	197793-9

Machine grease



Name	Related models	Capacity g	Part No.
Grease set	DHR171, DHR202, HM0871C, HM1111C, HR140D, HR166D, HR2230, HR2800, HR2810, HR2810T, HR2811F, HR2811FT, HR3200C, HR3210C, HR3210FCT, HR3540C, HR3541FC, HR4002, HR4013C, HR4501C, HR4510C, HR4511C, HR5212C	80	1914C6-5
	HK1820, HM1307C, HM1307CB, HM1317C, HM1317CB, HM1802, HM1812, HR2800, HR2810, HR2811F, HR2811FT, HR3210C, HR3210FCT, HR3540C, HR3541FC, HR4501C, HR4510C, HR4511C	-	1914C9-9
	HM0810, HM0810T, HM1201		1914C5-7
	HR140D, HR166D, HR4002, HR4501C	80	1914D0-4
	HM1306	100	1914A4-5
Oil vessel set	HR007G, HR010G, HR140D, HR166D, HR2300, HR2320T, HR2475, HR2600, HR2601, HR2631F, HR2631FT, HR2641, HR2652, HR2653, HR2653T		195127-0
Oil vessel set (for Russia)	DHR202, DHR241, DHR242, DHR263, DHR264, HR2230, HR2300, HR2475, HR2600, HR2631F, HR2631FT, HR2641, HR2652, HR2653	26	198176-6

Flange & lock nut

Still photo	Name	Related models	Thread size	Outer diameter mm	Hole diameter of attachable wheel mm	Part No.
	Lock nut 10-35 set	9556HP, GA4030	-	-	-	194608-1
	Inner flange 42CB set	DGA900, DGA901, GA037G, GA038G	-	-	-	198677-4
	Inner flange 45CC set	DGA900, DGA901, GA038G, GA7070, GA9070, GA9071	M14x2 DIN	45	22.23	198678-2
	Inner flange 47 set	All 115mm-230mm Angle Grinder	M14x2 DIN	47	22.23	192227-7
	Lock nut set	9564CV, 9564PC, 9564PCV, 9565CV, 9566CV, GA5010, GA5011, GA5020, GA6010, GA6020	5/8 INCH	45	22.23	193465-4
	Toolless lock nut set	DGA701, DGA901	M14x2 DIN	-	22.23	195354-9
	Lock nut 5/8-48 set	All 115mm-230mm Angle Grinder	5/8 INCH	48	-	193048-0

Rubber pad

Still photo	Name	Related models	Outer diameter mm (inch)	Max operating speed rpm	Part No.
	Rubber pad 76 set	9500NB	76 (3)	13,700	191102-4
	Rubber pad set	GA7060, GA7061, GA7061R, GA7070, GA7080, GA7081, GA7082, GA9050, GA9060, GA9060R, GA9061R, GA9070, GA9080, GA9081, GA9082	170 (6-11/16)	8,500	192978-2

Accessory kit

Still photo	Name	Related models	Part No.
	Sander kit	9237C	193958-1

Hook & loop pad for polisher, sander



Still photo	Name	Related models	Outer diameter mm (inch)	Part No.
	Pad 100 set	DPO500, DPO600, PO5000C, PO6000C	100 (4)	197925-8
	Pad 150 set	DPO500	150 (6)	197928-2
	Pad 123 set	BO5030, BO5031, BO5040, BO5041, DBO180	123 (4-7/8)	197468-0
	Pad 210 set	DSL801	210 (8-1/4)	199939-3 199940-8
	Pad 220 set		220 (8-5/8)	199938-5
	Pad complete set	DBO480, DBO481, DBO482, DBO484	-	191Y24-8
	Rectangle plate complete set		-	191Y23-0
	Triangle plate complete set		-	191Y22-2

Pad complete for sander





Still photo	Name	Related models	Outer diameter mm (inch)	Pad size mm	Part No.
	Pad 125 set	BO001CG, BO003CG	125 (5)	-	1914J2-2
	Pad 150 set	BO002CG, BO004CG	150 (6)	-	1914J3-0
	Pad complete set	BO007CG	-	-	1915E5-7
		BO3710, BO3711, DBO380, DBO381	-	-	194929-1
		DBO480, DBO481, DBO482, DBO484	114 X 102	-	194930-6 197464-8
		9046	-	-	197469-8
	Pad set	BO4900, BO4900V, BO4901	-	-	193522-8
		BO4565	-	-	197467-2
	Square pad set	BO005CG, BO006CG	-	80 X 130	1914H9-4
	Triangle pad set		-	100 X 150	1914J0-6

Grinding/ Sanding/ Polishing



Felt pad for polisher, sander

Still photo	Name	Related models	Outer diameter mm (inch)	Part No.
	Felt pad 150 set	BO6030, BO6050, DPO500, DPO600	150 (5-7/8)	193288-0
	Felt pad set	BO5031, BO5041, DBO180, DPO500, DPO600, PO5000C, PO6000C	125 (4-7/8)	196152-4

Sponge pad for polisher, sander

Still photo	Name	Related models	Outer diameter mm (inch)	Part No.
	Sponge pad 150 set	DPO600	150 (5-7/8)	197894-3
	Sponge pad 190 set	PV7001C	190 (7-1/2)	193470-1
	Sponge pad 80 set	DPV300, PV301D	80 (3-1/8)	191N90-9
				191N91-7

Wool pad for polisher, sander







Still photo	Name	Related models	Outer diameter mm (inch)	Part No.
	Wool pad 180 set	9237C, 9237CB, PV001G, PV7000C	180 (7-1/8)	192629-7
		9237CB, PV001G		191D53-5
	Wool pad 80 set	DPV300, PV301D	80 (3-1/8)	191N92-5

Wheel guard

Still photo	Name	Related models	Max diameter of compatible wheel mm	Bearing box type	Part No.
	Cutting wheel cover attachment 100 set	All 100mm Angle Grinder	100		191V54-1
		DGA404, DGA405, GA039G, GA042G, GA045G, GA4030			191V55-9
	Cutting wheel cover attachment 115 set	All 115mm Angle Grinder	115		199709-0
	Cutting wheel cover attachment 125 set	All 125mm Angle Grinder	125		199710-5
	Cutting wheel cover attachment 150 set	All 150mm Angle Grinder	150		191V56-7
	Cutting wheel cover attachment 150 set	9566PCV, GA035G, GA036G, GA6020, GA6021, GA6021C, GA6040C	150		191X09-8

Still photo	Name	Related models	Max diameter of compatible wheel mm	Bearing box type	Part No.
	Cutting wheel cover attachment 150A set	GA051G	150		191V57-5
	Toolless wheel cover 115AK set	DGA504, DGA506, DGA508, DGA513, DGA514, DGA517	115		198784-3
	Wheel cover	9500NB	-	SINGLE NOTCH	192003-9
	Wheel cover 115C set	GA004G, GA007G, GA012G, GA015G, GA022G, GA025G, GA028G, GA049G, GA4590, GA4591, GA4592, GA4593, GA4594, GA4595	115		1910X9-2
	Wheel cover 115CKL set	DGA504, DGA506, DGA508, DGA513, DGA514, DGA517	-		198783-5
	Wheel cover 115CL set	GA4590, GA4591, GA4595, GA5093, GA5095	115	5 NOTCHES, NEW TOOLLESS	1910X7-6
	Wheel cover 125C set	GA005G, GA008G, GA013G, GA016G, GA023G, GA026G, GA029G, GA050G, GA5090, GA5091, GA5092, GA5093, GA5094, GA5095	125		1910Y0-7
	Wheel cover 125CL set	GA5090, GA5091, GA5092, GA5093, GA5095	125		1910X8-4
	Wheel cover 125CT set	GA055G	-		1915U6-7

Grip, loop handle for angle grinder

Still photo	Name	Related models	Thread size	Part No.
	Grip 35 set	All 100mm-150mm Angle Grinder	M8	1910X6-8
			M8	1910X5-0
	Vibration proof grip set		M8	194514-0
	Vibration proof grip set	GA7050R, GA9050R, GA9090	M14	194543-3
	Loop handle set	GA5010, GA5011, GA5020, GA5020C, GA5021, GA5021C, GA6010, GA6020, GA6020C, GA6021, GA6021C	M8	194483-5
	Grip attachment set	GA9020, GA9020S, GA9030	M14	194684-5
	Loop handle set	GA7060, GA7061, GA7061R, GA7064, GA7070, GA7080, GA7081, GA7082, GA7090, GA9060, GA9060R, GA9061R, GA9062R, GA9070, GA9071, GA9080, GA9081, GA9082, GA9090	M14	199176-9













Grip, loop handle

Still photo	Name	Related models	Thread size	Part No.
	Grip 36 set	DPO500, DPO600, PO5000C, PO6000C	M8	198043-5

Lock nut release socket

Still photo	Name	Related models	Compatible lock nut	Part No.
	Lock nut release socket 35 set	All 115mm-230mm Angle Grinder	35	194305-9

Dust cover for angle grinder

Still photo	Name	Related models	Part No.
	Dust cover attachment set	9564P, 9564PCV, 9565PCV, 9566PCV	195446-4
		9565C, 9565CR, 9565CV, 9565CVR, GA5080R	193903-6
		GA4040, GA4040C, GA4540, GA4540C, GA4540R, GA4542C, GA5040, GA5040C, GA5040R, GA5041C, GA5042C, GA6040, GA6040C, GA6040R, GA6042C, PC5010C, SA5040C	198719-4
		GA4590, GA4591, GA4592, GA5090, GA5091, GA5092	191V72-9
		GA4593, GA4594, GA4595, GA5093, GA5094, GA5095	191Y29-8
		GA5010, GA5011, GA5021, GA5021C, GA6010, GA6021, GA6021C, GA7010C, GA7012C, GA9010C, GA9012C	193956-5
		GA5020, GA6020	194482-7
		GA5050R, GA5051R	199514-5
		GA7031, GA9031	194289-1
		GA7060, GA7061, GA7061R, GA7064, GA7081, GA7082, GA9060, GA9060R, GA9061R, GA9062R, GA9081, GA9082	197476-1
		GA7070, GA9070, GA9071	191T15-9
		GA7080, GA9080	191T14-1
		GA9050R	195059-1

Extension handle set for drywall sander





Name	Related models	Part No.
Extension handle set	DSL801	199937-7

Collet cone , collet nut for die grinder

Still photo	Name	Related models	Collet size mm (inch)	Part No.
	Collet cone 1/4" set	GD0800C, GD0801C, GD0810C	(1/4)	197023-8
		GD0800C, GD0801C, GD0810C, GD0811C		192986-3
	Collet cone 1/8" set	GD0800, GD0800C, GD0801C, GD0810C, GD0811C	(1/8)	193144-4
		GD0800C, GD0801C, GD0810C, GD0811C		192987-1
	Collet cone 3 set	GD0800C, GD0801C, GD0810C, GD0811C	3	193011-3
	Collet cone 6 set	GD0801C, GD0810C, GD0811C	6	193012-1
	Collet cone 8 set	GD0800C, GD0801C, GD0810C, GD0811C	8	192988-9

Punch plate for sander

Still photo	Name	Related models	Part No.
	Punch plate set	9046, BO4900, BO4900V, BO4901	192523-3
		BO3710, BO3711, DBO380, DBO381	194947-9
			194948-7

Side handle set for die grinder

Still photo	Name	Related models	Part No.
	Side handle set	DGD800, DGD801, GD0600, GD0601, GD0602, GD0800, GD0800C, GD0801C, GD0810C, GD0811C	192985-5

Vise holder set for die grinder





Still photo	Name	Related models	Part No.
	Vise holder set	GD0800C	193141-0

Grinding/ Sanding/ Polishing



Dust box assembly, paper dust bag, filter for sander

Still photo	Name	Related models	Part No.
	Filter set	BO3710, BO3711, BO4555, BO4556, BO4557, BO4558, BO4565, BO4566, BO5030, BO5031, BO5040, BO5041, DBO180, DBO380, DBO381, DBO480, DBO481, DBO482, DBO484	195133-5
			195134-3
	Paper dust bag holder set	9046, BO4900, BO4900V, BO6030	193525-2
	Paper dust bag set		
		BO4555, BO4556, BO4557, BO4558, BO4565, BO4566, DBO180, DBO480, DBO481, DBO482, DBO484	194746-9
		BO4900, BO4900V	193526-0

Belt sander plate

Still photo	Name	Related models	Part No.
	Carbon plate set	9404	193201-8
		9903, BS001G	193197-3
		9920	193198-1
	Cork rubber plate set	9404	193202-6
		9920	193200-0



Stand for belt sander

Still photo	Name	Related models	Part No.
	Belt sander stand set	9404, 9903, 9920	193055-3
	Stand set	9032, DBS180	193618-5

Guide rule for sander

Still photo	Name	Related models	Part No.
	Guide rule set	BS001G	1915E3-1

Sanding shoe assembly

Still photo	Name	Related models	Part No.
	Sanding shoe set	9404	193072-3
		9903, BS001G	193070-7
		9920	193071-5

Clamp complete for belt sander

Still photo	Name	Related models	Part No.
	Clamp complete set	9910, 9911, BS001G	192694-6

Cutting

Water supply set for cutter



Name	Related models	Part No.
Water supply pipe set	4100NH3	196431-0
		196432-8

Rear cover

Name	Related models	Part No.
Rear cover attachment set	4100KB, 4100NH2	196944-1

Base cover

Still photo	Name	Related models	Part No.
	Base cover set	4100NH2, DCC500, DCC501	196943-3

Tilt base set for cutter

Still photo	Name	Related models	Part No.
	Tilt base set A	4100NH2	199494-5
	Tilt base set B		199495-3
	Tilt base set C		199496-1
	Tilt base set D		199713-9
	Tilt base set E		199714-7

Portable band saw stand

Still photo	Name	Related models	Part No.
	Stand of chain vise set	2107F	194026-3
			196326-7
-	Stand of parallel assembly		196327-5

Cover for portable band saw

Still photo	Name	Related models	Part No.
	Wheel cover set	DPB182	197975-3

Blade wax

Still photo	Name	Related models	Part No.
	Cutting wax set	2107F, DPB180, PB002G	191897-9

Trolley kit



Still photo	Name	Related models	Part No.
	Cart set	CE001G	1914H2-8
			1915C0-3
			1915C1-1

Water supply set For power cutter



Still photo	Name	Related models	Part No.
	Hose assembly set	CE001G, CE003G, CE004G, DCE090	1915Y2-3

Shear

Still photo	Name	Related models	Part No.
-	Center blade 16 set	DJS130	194696-8
	Shear blade set	JS1602	191383-0
	Shear head assembly 16 set	DJS130	194694-2
	Shear head assembly set		194695-0

Cutting

For PP001G, DPP200 Combination of punch and die

- Punching holes through a thin structural metal plate may cause deformation of the plate and burr on the holes.
- If you need precision punching, see the tables below to select an optimum combination of punch and die.



Round punching

Workpiece thickness (mm)	Punch		Die		Workpiece thickness (mm)				Punch		Die	
	Hole size (mm)	Part No.	Hole size	Part No.	Mild Steel	Stainless Steel (Inox)	Channel		Hole size (mm)	Part No.	Hole size	Part No.
Aluminum, Mild Steel							PP001G	DPP200				
2-3.2	6	SC05340040	SA6	SC00000202	2-4	3-4	-	-	6	SC05340040	SB6	SC00000203
2-3.2	6.5	SC05340050	SA6.5	SC00000204	2-6	3-4	-	-	6.5	SC05340050	SB6.5	SC00000205
2-3.2	8	SC05340060	SA8	SC00000206	2-6	3-4	-	-	8	SC05340060	SB8	SC00000207
2-3.2	8.5	SC05340070	SA8.5	SC00000208	2-6	3-4	-	-	8.5	SC05340070	SB8.5	SC00000209
2-3.2	10	SC05340080	SA10	SC00000210	2-6	3-4	8	7.5	10	SC05340080	SB10	SC00000211
2-3.2	11	SC05340090	SA11	SC00000212	3-9	3-6	8	7.5	11	SC05340090	SB11	SC00000213
2-3.2	12	SC05340100	SA12	SC00000214	3-9	3-6	8	7.5	12	SC05340100	SB12	SC00000215
2-3.2	13	SC05340110	SA13	SC00000216	3-9	3-6	8	7.5	13	SC05340110	SB13	SC00000217
2-3.2	14	SC05340120	SA14	SC00000218	3-9	3-6	8	7.5	14	SC05340120	SB14	SC00000219
2-3.2	15	SC05340130	SA15	SC00000220	3-9	3-6	8	7.5	15	SC05340130	SB15	SC00000221
2-3.2	18	SC05340150	SA18	SC00000222	3-9	3-6	8	7.5	16	SC05340140	SB16	SC05332710
2-3.2	20	SC05340160	SA20	SC05352500	3-9	3-6	8	7.5	18	SC05340150	SB18	SC00000223
					3-9	3-6	8	7.5	19	SC05340170	SB19	SC05332740
					3-9	3-6	8	7.5	20	SC05340160	SB20	SC05352510

PP001G only

10	3-6	10	-	12	SC05340400	SB12	SC00000215
10	3-6	10	-	13	SC05340410	SB13	SC00000217
10	3-6	10	-	14	SC05340420	SB14	SC00000219
10	3-6	10	-	15	SC05340430	SB15	SC00000221
10	3-6	10	-	16	SC05340440	SB16	SC05332710
10	3-6	10	-	18	SC05340450	SB18	SC00000223
10	3-6	10	-	19	SC05340460	SB19	SC05332740

Oblong punching

Workpiece thickness (mm)	Punch		Die		Workpiece thickness (mm)				Punch		Die	
	Hole size (mm)	Part No.	Hole size	Part No.	Mild Steel	Stainless Steel (Inox)	Channel		Hole size (mm)	Part No.	Hole size	Part No.
Aluminum, Mild Steel							PP001G	DPP200				
2-3.2	6.5x10	SC05340200	A6.5x10	SC00000243	2-6	3-4	-	-	6.5x10	SC05340200	B6.5x10	SC00000244
2-3.2	6.5x13	SC05340210	A6.5x13	SC00000245	2-6	3-4	-	-	6.5x13	SC05340210	B6.5x13	SC00000246
2-3.2	8.5x13	SC05340220	A8.5x13	SC00000247	2-6	3-4	-	-	8.5x13	SC05340220	B8.5x13	SC00000248
2-3.2	8.5x17	SC05340230	A8.5x17	SC00000249	2-6	3-4	-	-	8.5x17	SC05340230	B8.5x17	SC00000250
2-3.2	9x13.5	SC05340240	A9x13.5	SC00000251	2-6	3-4	-	-	9x13.5	SC05340240	B9x13.5	SC00000252
2-3.2	9x18	SC05340250	A9x18	SC00000253	2-6	3-4	-	-	9x18	SC05340250	B9x18	SC00000254
2-3.2	10x15	SC05340260	A10x15	SC00000255	2-8	3-6	8	7.5	10x15	SC05340260	B10x15	SC00000256
2-3.2	10x20	SC05340270	A10x20	SC00000257	2-8	3-6	8	7.5	10x20	SC05340270	B10x20	SC00000258
2-3.2	11x16.5	SC05340280	A11x16.5	SC00000259	2-9	3-6	8	7.5	11x16.5	SC05340280	B11x16.5	SC00000260
2-3.2	12x18	SC05340290	A12x18	SC00000261	2-9	3-6	8	7.5	12x18	SC05340290	B12x18	SC00000262
2-3.2	13x19.5	SC05340300	A13x19.5	SC00000263	2-9	3-6	8	7.5	13x19.5	SC05340300	B13x19.5	SC00000264
2-3.2	14x21	SC05340310	A14x21	SC00000265	2-9	3-6	8	7.5	14x21	SC05340310	B14x21	SC00000266
					2-9	3-6	8	7.5	15x21	SC05340320	B15x21	SC05340550

Vertical oblong punching

Workpiece thickness (mm)				Punch		Die	
Mild Steel	Stainless Steel (Inox)	Channel		Hole size (mm)	Part No.	Hole size	Part No.
2-9	3-6	PP001G	DPP200	8	7.5	20x12	SC05340350
2-9	3-6	8	7.5	20x14	SC05340360	B20x12	SC05340510
						B20x14	SC05340530

Work stand set

Model No.	Part No.
PP001G, DPP200	SC03801080



Slide stopper

Model No.	Part No.
PP001G, DPP200	SC03300790

Punching up to 40 mm depth from the edge of the workpiece can be done using the optional slide stopper.

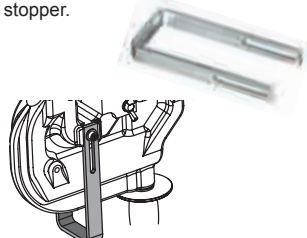

Hydraulic oil

Model No.	Viscosity	Size (mL)	Part No.
DPP200, DSC121, DSC163, DCS191, DSC191R, PP001G	ISO46	500	SC09003320
SC001G	ISO32	35	SC09003270
		150	SC09003280
		500	SC09003330



Threaded rod cutter blade

Still photo	Name	Related models	Thread type	Thread size	Part No.
	Cutter blade M10 set	DSC102, SC103D	ISO metric	M10	199083-6
	Cutter blade M8 set			M8	199085-2
	Cutter blade M6 set			M6	199087-8
	Cutter blade W5/16 set		ISO inch / BSW	5/16"-18 UNC / W5/16	199443-2
	Cutter blade W1/4 set			1/4"-20 UNC / W1/4	199444-0
	Cutter blade W3/8 set			3/8"-16 UNC / W3/8	199081-0
	Cutter blade M8 set	DSC121	ISO metric	M8	SC09002700
	Cutter blade M10 set			M10	SC09002710
	Cutter blade M12 set			M12	SC09002720
	Cutter blade W3/8 set		BSW	W5/16	SC09002750
	Cutter blade W3/8 set			W3/8	SC09002730
	Cutter blade W1/2 set			W1/2	SC09002740

Accessory for crimper

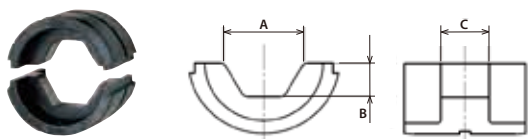

Name	Related models	Range (mm ²)	A (mm)	B (mm)	C (mm)	Part No.
DIN K DIE K6	DTC301, DTC302	Cu 10	6.2	2.2	12	ZM00000216
DIN K DIE K8		Cu 16	8.2	3.0	12	ZM00000217
DIN K DIE K10		Cu 25 / Al 16	9.7	3.6	12	ZM00000218
DIN K DIE K12		Cu 35 / Al 25	11.8	4.4	14	ZM00000219
DIN K DIE K14		Cu 50 / Al 35	13.8	5.3	14	ZM00000220
DIN K DIE K16		Cu 70 / Al 50	15.8	6.0	14	ZM00000221
DIN K DIE K18		Cu 95 / Al 70	18	7.0	14	ZM00000222
DIN K DIE K20		Cu 120 / Al 95	19.8	7.6	14	ZM00000223
DIN K DIE K22		Cu 150 / Al 120	22.3	8.7	13	ZM00000224
DIN K DIE K25		Cu 185 / Al 150	24.3	9.6	12	ZM00000225
DIN K DIE K28		Cu 240 / Al 185	27.8	11.5	11	ZM00000226
DIN K DIE K32		Cu 300 / Al 240	31.5	13.6	9	ZM00000227
HEX. DIE K34		Cu 400 / Al 300	33.7	14.5	7	ZM00000228

Multi cutter blade

Still photo	Name	Related models	Part No.
	Multi cutter blade set	CP100D	198603-3

Multi tool blade adapter

Still photo	Name	Related models	Part No.
	Adapter A set	DTM50, TM3000C, TM3010C, TM30D	196271-6

Crown molding stopper set



Still photo	Name	Related models	Part No.
	Crown molding stopper set	DLS110, DLS111, DLS112, DLS211, DLS212, LS003G, LS004G, LS1019, LS1019L, LS1219, LS1219L	192628-9
		LS1030N, LS1040, LS1040F, LS1045	192622-1

Sub plate for miter saw

Still photo	Name	Related models	Part No.
	Sub plate set	LS1040, LS1040F	193471-9
			195934-1

Extension table

Still photo	Name	Related models	Part No.
	Left table set	2704, 2704N	194086-5
	Rear table set		194087-3
	Sub table L set	2703	192798-4
	Sub table R set		192797-6

Dado flange set



Still photo	Name	Related models	Part No.
	DADO flange set	2703	192693-8

Sawing

Side grip for circular saw

Still photo	Name	Related models	Part No.
	Grip set	5800NB, 5806B	194275-2

Sub base set

Still photo	Name	Related models	Part No.
	Sub base assembly set	DLS110, DLS111, DLS112, DLS211, DLS212, LS1019, LS1019L, LS1219, LS1219L	191C01-8
		LS004G	191U61-8

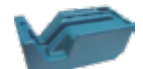

Saw storage holder

Still photo	Name	Related models	Part No.
	Protective stand set	5402NA	194701-1

Rip fence for circular saw

Still photo	Name	Related models	Part No.
-	Guide rule set	DRS780, RS001G, RS002G	199249-8

Parallel guide, rip fence for jig saw

Still photo	Name	Related models	Part No.
	Guide rule set	4327, 4329, JV0600, JV101D, JV103D	192732-4
		4350CT, 4350FCT, 4350T, 4351CT, 4351FCT, DJV180, DJV181, DJV182, JV002G	193516-3

Support base



Still photo	Name	Related models	Part No.
	Support base set	DJV186	1915R3-2

Anti-splintering device for jig saw

Still photo	Name	Related models	Part No.
	Kerf board set	4326, 4327, 4329, 4350CT, 4350FCT, 4350T, 4351CT, 4351FCT, DJV180, DJV181, DJV182, DJV184, DJV185, JV001G, JV002G, JV0600, JV101D, JV102D, JV103D, JV183D	192557-6

Dust box for miter saw

Still photo	Name	Related models	Part No.
	Dust box set	LS0714, LS0714F, LS0714FL	194175-6

Flourescent light set



Still photo	Name	Related models	Part No.
	Flourescent light set	2107F, LS1040F	193730-1

Depth gauge



Still photo	Name	Related models	Part No.
	Depth gauge assembly set	DTM53	1916E4-5

For LB1200F

Still photo	Name	Related models	Part No.
	Extension table set	LB1200F	JM21000300
	Circular cutting attachment set		JM21000320
	Belt sanding attachment set		JM21000330

Workshop stand

Still photo	Name	Related models	Part No.
	Stand set WST01N	DLS110, DLS111, DLS112, DLS211, DLS212, DLS713, DLS714, LS002G, LS003G, LS004G, LS0714, LS0815FL, LS1019, LS1019L, LS1040, LS1219, LS1219L, LS1221	198686-3
		DLS110, DLS111, DLS211, DLS212, DLS713, DLS714, LS002G, LS003G, LS004G, LS0815F, LS0815FL, LS1019, LS1019L, LS1040, LS1219, LS1219L	198687-1
	Stand set WST05		WST05
	Stand set WST06	DLS110, DLS111, DLS112, DLS211, DLS212, DLS713, DLS714, LS002G, LS003G, LS004G, LS0714/FL/L/F, LS0815FL/F, LS0816F, LS1017L, LS1018L, LS1019, LS1019L, LS1030N, LS1040/F, LS1045, LS1110F, LS1440, LS1221, LS1219L	WST06
	Stand set WST07		WST07
	Stand set	2012NB, DLS110, DLS111, DLS112, DLS211, DLS212, DLS713, DLS714, LS002G, LS003G, LS004G, LS0714, LS0815F, LS0815FL, LS1019, LS1019L, LS1030N, LS1040, LS1219, LS1219L	198688-9
	Stand set WST03	MLT100, MLT100N, 2702, 2703	JM27000300
		2703	193920-6
	Stand set WST04	2704, 2704N	194093-8

Guide rail



Overall length (m)	Part No.
1.0	199140-0
1.4	194368-5
1.5	199141-8
1.9	194925-9
3.0	194367-7

Repair parts for guide rail

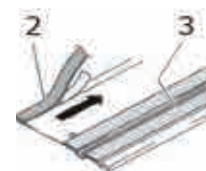
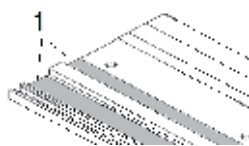

Item	Part No.	
1	Seat 10m set (For upper plastic tape repair)	194416-0
2	Position Seat 1.4m	191J53-1(USA)
	Position Seat 1.9m	194910-2 194915-2(EU)
	Position Seat 3.0m	194419-4
3	Rubber Seat 10m set (For lower rubber tape repair)	194417-8 191J54-9(USA)

Clamp set

(Use with Guide rail)



Type	Part No.
A: Standard	194385-5
B: Quick	199826-6
C: Push clamp	1913K5-7

Sawing

Bevel guide set

Adjustable angle of Guide Rail
The Parallel guide set cannot be used with the Limit stop set.

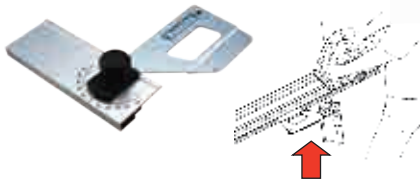

Part No.
196664-7



Parallel guide set

Guide rail parallelly to any position from the end face of workpiece.
Stable size cutting can be done by setting.
The Parallel guide set cannot be used with the Limit stop set.



Part No.
1913K7-3



Guide rail Joint connector 2pcs set

The Parallel guide set cannot be used with the Limit stop set.

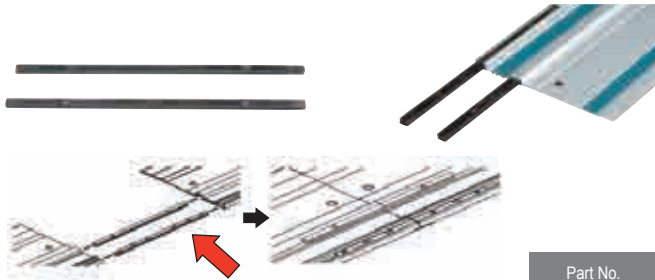

Part No.
198885-7

Limit stop set

Can reduce the risk of unintentional backward movement by using with Guide rail.

Use with optional accessories that block the groove of the Guide rail, such as the Guide rail adapter, Parallel guide, and Bevel guide, is not possible.



Model No.	Part No.
CA5000, DHS782, DHS783, DHS900, DSP600, DSP601, HS004G, HS009G, HS011G, SP001G, SP6000,	1913J9-2

Guide rail adaptor

Items	A	B	C	D	E	F	G	H	I	J	N	O	P	Q	R		
	Circular saw										Jig saw		Router	Trimmer	Cutter		
Models	HS7100 HS7101	DHS630 HS6100 HS6101	HS7601 HS7610 HS7611	DHS680	HS6600 HS6601	HS0600	5705R	DHS660 DHS661	5903R	5103R	DJV141 DJV142 DJV180 DJV181 DJV182 JV001G JV002G 4350CT 4350FCT 4350FT 4350T 4351CT 4351FCT 4351T	DJV186 DJV184 DJV185 JV002G JV102D JV103D JV101D JV0600	RP001G RP0900 RP0910 RP1110C RP1111C RP1800 RP1800F RP1801 RP1801F RP1802 RP1802F RP1803 RP1803F RP2300FC RP2301FC RP2302FC RP2303FC	RT001G DRT50 RT0700C RT0702C	Use with Plunge base assembly (P/N: 195563-0 EU: 196094-2)	DCC500 DCC501 4100NH2 4100NH2W DCC500 DCC501	4100KB 4100NH2 4100NH2R 4100NH2W DCC500 DCC501
Part No.	195837-9 *197252-3	195838-7	197005-0 191B18-5 (w/carton)	196953-0 191B17-7 (w/carton)	197462-2 191B19-3 (w/carton)	198566-3 198570-2 (EU)	192505-5	199232-5	192506-3	192507-1	*197252-3	193517-1	198704-7	194579-2	198673-2 1916F4-2		

*Includes rule bars for items A, B, and N

If you have adapter of the same type, they can also be used in combination with the following parts.

Part No.	195840-0	195841-8	196994-6	196954-8	197463-0							347393-7	922207-7	922107-1		

Milling/ Planing

Set plate

Still photo	Name	Related models	Size mm	Part No.
	Set plate set	DKP180, DKP181, KP001G, KP0800	82	193540-6



Stand for hand planer

Name	Related models	Part No.
Planer stand set	1911B	194057-2



Stand for benchtop planer

Still photo	Name	Related models	Part No.
	Stand set	2012NB	193902-8



Dust bag for milling, planing

Still photo	Name	Related models	Part No.
	Dust bag assembly set	DKP181, KP001G	191C21-2
	Dust bag set	1911B	196300-5





Edge fence, guide rule

Still photo	Name	Related models	Part No.
	Guide rule set	1804N, 1805N	191454-3
		1911B	191455-1

Collet cone/nut for trimmer, router

Still photo	Name	Related models	Size mm (inch)	Part No.
	Collet cone 6 set	RP0910, RP1111C	6	193180-0
	Collet cone 6.35 set	RD1101, RF1101, RP1101	(1/4)	193214-9
	Collet cone 8 set	RP1111C	8	193178-7





Straight guide assembly for trimmer, router

Still photo	Name	Related models	Type	Part No.
	Straight guide set	RD1101, RF1101, RP1101	-	193073-1
		DRT50, RD1101, RF1101, RP0900, RP1101, RT001G, RT0700C		193358-5
		DRT50, RD1101, RF1101, RP0900, RP1800, RP2301FC, RT001G, RT0700C		193312-9
		DRT50, RP0900, RP0910, RP1111C, RP1800, RP1800F, RP1802, RP1802F, RP1803, RP1803F, RP2300FC, RP2301FC, RP2302FC, RP2303FC, RT001G, RT0700C, RT0702C	Micro adjustment	195136-9
		RP1800, RP1800F, RP1802, RP1802F, RP1803, RP1803F, RP2300FC, RP2301FC, RP2302FC, RP2303FC		194935-6







Trimmer guide holder

Still photo	Name	Related models	Part No.
	Guide holder set	DRT50, RT001G, RT0700C, RT0702C	195564-8



Router base assembly

Still photo	Name	Related models	Part No.
	Base plate set	RD1101, RF1101, RP1101	193155-9
	Base set	RP1101	193457-3
	Plunge base set	DRT50, RT001G, RT0700C, RT0702C	195563-0
			196094-2

Trimmer base assembly

Still photo	Name	Related models	Type	Part No.
	Tilt base set	DRT50, RT001G, RT0700C, RT0702C	-	198987-9
	Trimmer base assembly set	3709, 3710, 3712	Transparent base, fine depth a	194267-1
			Transparent base	194268-9
			For chamfering, fine depth ad	194269-7
			For chamfering	194270-2
	Trimmer base set (12 pcs)	DRT50, RT001G, RT0700C, RT0702C	-	196615-0

Offset base assembly

Still photo	Name	Related models	Part No.
	Offset base set	DRT50, RT001G, RT0700C	196922-1
			195562-2
			196093-4

Circular guide set for cut-out tool

Still photo	Name	Related models	Part No.
	Circular guide set	3706	193448-4

Fastening/ Fixing

Drywall guide bit



Name	Related models	Overall diameter (inch)	Shank diameter mm (inch)	Range	Part No.
Drywall guide bit 3.18 set	3706, DCO180, DCO181	(1/8)	3.18 (1/8)	THREE-STAR	191G69-8
Drywall guide bit 6.35 set	3706, DCO180, DCO181	(1/4)	6.35 (1/4)		193447-6

Rivet gun maintenance kit

* short madre!

**Model DRV150: Pipe is not necessary for operation.

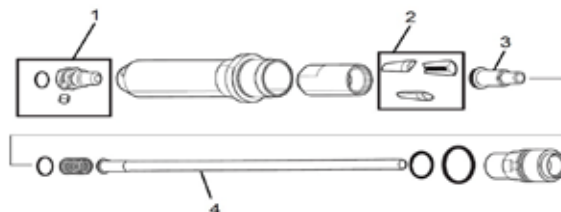

Shape	Model No.	Rivet size	1		Hade / Jaw case		2	3	4	1+3+4	1+3					
			Nose piece size	Part No.	(-DEC. 2023)	(JUN. 2023 -)						Color / Jaw size	Color / Jaw pusher size	Color / pipe size	Nose piece, Jaw pusher and pipe set	Part No.
	DRV150, DRV250	2.4 mm	2.4	Marking on 6.4 327279-1 / 327281-4	Marking on 4.8S 327691-5 / 327B83-0	Black / 4.8 199731-7	Gray / 1.9 127478-3	Silver / 2.3 162747-5	199729-4	1911U6-3	199728-6	1911U4-7	191F80-4	191C04-2		
			2.4 S												127230-9	127478-3
		*2.4 mm	2.4 S						127230-9	127478-3	162747-5					
			122D82-7						127478-3	162747-5						
		3.2 mm	3.2						127229-4	127477-5	162746-7					
			3.2 S						122D81-9	127477-5	162746-7					
		*3.2 mm	3.2 S						122D81-9	127477-5	162746-7					
			4.0						127228-6	127476-7	**162745-9					
		4.0 mm	4.0						127228-6	127476-7	**162745-9					
			4.0 S						122D80-1	127476-7	**162745-9					
		*4.0 mm	4.0 S						122D80-1	127476-7	**162745-9					
			4.8						127225-2	127475-9	**162744-1					
		4.8 mm	4.8						127225-2	127475-9	**162744-1					
			4.8 S						127689-0	127475-9	**162744-1					
*4.8 mm	4.8 S	127689-0	127475-9	**162744-1												
	6.0	127224-4	127474-1	162744-1												
DRV250	6.0 mm	6.0	Marking on 6.4 327279-1 / 327281-4	Marking on 6.4S 327830-7 / 327831-5	Silver / 6.4 199730-9	Gray / 4.0 127474-1	Black / 4.2 162744-1	199725-2	1911V0-2	191F78-1	1911U8-9	1911U8-9	1911U8-9			
		6.0 S												122D79-6	127474-1	162744-1
	*6.0 mm	6.0 S						122D79-6	127474-1	162744-1						
		6.4						127223-6	127473-3	162743-3						
	6.4 mm	6.4						127223-6	127473-3	162743-3						
		6.4 S						122B72-8	127473-3	162743-3						
	*6.4 mm	6.4 S						122B72-8	127473-3	162743-3						
		6.4 S						122B72-8	127473-3	162743-3						





Tool protector

Still photo	Name	Related models	Color	Part No.
	Protector set A	DRV150	White	191G65-6
	Protector set A Blue		Blue	191S62-4
	Protector set A Red		Red	191S61-6
	Protector set B	DRV250	White	191G66-4
	Protector set B Blue		Blue	191S64-0
	Protector set B Red		Red	191S63-2

Grease set

Still photo	Description	Related models	Part No.
	5g for Jaw grease	DRV150, DRV250	191D57-7 191D58-5

Tie wire set

Still photo	Name	Related models	Shank diameter mm	Part No.
	Poly coated tie wire set	DTR180, DTR181	0.8	191J59-9
	Tie wire set	DTR180	0.8	191L22-4
		DTR180, DTR181		199137-9
		TR001G		-

Extension handle for rebar tying tool



Still photo	Name	Related models	Part No.
	Extension handle set	DTR180, DTR181, TR001G	1915N6-8

Wire guide

Still photo	Name	Related models	Type	Part No.
	Wire guide B complete (EG) set	DTR181	Attachment for tying rebars wi	1913F2-8

Oil supply

Still photo	Name	Related models	Part No.
-	Oil supply set	TR001G	199109-4
	Oil vessel set		194381-3

Reber binding attachment set

Still photo	Name	Related models	Part No.
	Rebar binding attachment set	TD022D	194731-2

Magazine set

Still photo	Name	Related models	Magazine capacity nails	Part No.
	Extended capacity magazine set	BN001G	-	1917P3-0
				1917P4-8
		BN002G, DBN901	78	1914P2-4
				1914P9-0
		DBN900	97	1914P1-6
				1915W4-5
	Magazine set (20 pin)	GN420C	20	196806-3
	Magazine set (40 pin)		40	196805-5

Nailer maintenance kit

Still photo	Name	Related models	Part No.
-	Cleaning set	GF600	195140-8
		GF600, GN420C	194852-0
-			194853-8

Nose adapter

Still photo	Name	Related models	Part No.
	Nose adapter set	BN001G, BN002G	1916P4-2

Depth adjuster

Still photo	Name	Related models	Part No.
	Adjuster set	DST112, ST113D	197731-1

Fastening/ Fixing

Nails, Staples and Screws Wire coil Nails (Flat Type)

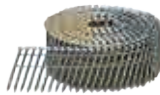

Dia	Length	Shank	Nails /carton	Part No.
For Model: AN560, AN760				
2.5mm (0.099")	45mm (1-3/4")	Smooth	10,800	F-30810
	50mm (2")	Screw Chisel		F-30865
		Smooth		F-31243
For Model: AN760, AN960, AN961				
2.5mm (0.099")	57mm (2-1/4")	Screw Chisel	8,100	F-30878
		Smooth		F-31256
	65mm (2-1/2")	Screw Chisel		F-30900
For Model: AN560, AN760				
2.8mm (0.110")	50mm (2")	Smooth	9,000	F-30823
2.9mm (0.113")		Screw Chisel		F-30849
		Smooth		F-30971
For Model: AN760, AN960, AN961				
2.9mm (0.113")	57mm (2-1/4")	Screw Chisel	6,750	F-31272
	65mm (2-1/2")			F-30881
	71mm (2-13/16")			F-31285
3.1mm (0.120")	65mm (2-1/2")	Smooth	6,075	F-30836
	75mm (3")			F-31298
3.2mm (0.120")	75mm (3")	Screw Chisel	4,050	F-31320
3.3mm (0.131")	65mm (2-1/2")	Smooth		F-30852
For Model: AN960, AN961				
3.4mm (0.135")	75mm (3")	Smooth	3,600	F-31359
3.1mm (0.120")	85mm (3-1/4")	Smooth	4,050	F-31304
		Screw Chisel		F-31333
	90mm (3-1/2")	Smooth		F-31317
3.2mm (0.120")	90mm (3-1/2")	Screw Chisel	4,050	F-31346
3.8mm (0.146")		Smooth	2,700	F-31362

Wire coil nails (Conical Type)

For Model: AN560

Dia	Length	Shank	Nails /carton	Part No.
2.1mm (0.083")	32mm (1-1/4")	Smooth	21,600	F-32766
	38mm (1-1/2")	Smooth	18,000	F-32779
		Screw		F-32801

For Model: AN560, AN760

Dia	Length	Shank	Nails /carton	Part No.
2.1mm (0.083")	45mm (1-3/4")	Smooth	18,000	F-32782
		Screw		F-32814
	50mm (2")	Smooth	14,400	F-32795
		Screw		F-32827

Wire coil nails (Roofing nail)

(7,200 pcs/box)

For Model: AN454



Dia	Length	Shank	Nails /carton	Part No.
3.1mm (0.120")	22mm (7/8")	Smooth	7,200	F-30762
	25mm (1")			F-30775
	32mm (1-1/4")			F-30788
	38mm (1-1/2")			F-30791
	45mm (1-3/4")			F-30807

Paper tape nail clipped-head

For Model: AN943, , BN001G, DBN900



Dia	Length	Shank	Finish	Nails /carton	Part No.
2.9mm (0.113")	60mm (2-3/8")	Smooth	Bright	3,000	F-30566
3.1mm (0.120")	75mm (3")	Smooth	Bright		F-30579
			Galvanized		F-30582
		Ring	Galvanized		F-30595
	83mm (3-1/4")	Smooth	Bright		F-30601
3.3mm (0.131")	75mm (3")	Smooth	Bright		F-30614
			Galvanized		F-30627
	83mm (3-1/4")	Smooth	Bright		F-30630
			Galvanized		F-30643
	90mm (3-1/2")	Smooth	Bright		F-30656
			Galvanized		F-31645

Pin nail



Model No.	Type	Length	Part No.
AF201Z, AF353, DPT353, PT354D, PT001G	23Ga(φ0.6) Pin Nail (10,000 pcs/box)	18mm (11/16")	F-31825
		25mm (1")	F-31838
		30mm (1-3/16")	F-31841
AF353, DPT353, PT354D, PT001G	23Ga(φ0.6) Stainless Pin Nail (10,000 pcs/box)	35mm (1-3/8")	F-31854
		18mm (11/16")	F-32142
AF201Z, DPT353, PT354D	23Ga(φ0.6) Stainless Pin Nail (10,000 pcs/box)	25mm (1")	F-32155
		30mm (1-3/16")	F-32168
		35mm (1-3/8")	F-32171

Finish nail

Model No.	Type	Length	Part No.
AF601, DBN600, DBN601	16 ga Finish Nail (2,000 pcs/box)	25mm (1")	F-33922
		30mm (1-3/16")	F-33935
		32mm (1-1/4")	F-33948
		35mm (1-3/8")	F-33951
		38mm (1-1/2")	F-33964
		40mm (1-9/16")	F-33977
		45mm (1-3/4")	F-33980
		50mm (2")	F-33993
		57mm (1-1/4")	F-34001
		60mm (2-3/8")	F-34014
		64mm (2-1/2")	F-34027
AF635, DBN620	15Ga Finish Nail (4,000 pcs/box)	32mm (1-1/4")	F-31960
		38mm (1-1/2")	F-31973
		45mm (1-3/4")	F-31986
		50mm (2")	F-31999
		57mm (1-1/4")	F-32007
		64mm (2-1/2")	F-32010

Brad nail



Model No.	Type	Length	Part No.
AF506, DBN500, DBN501, DFN350, FN001G	18Ga Brad Nail (5,000 pcs/box)	15mm (5/8")	F-31867
		20mm (3/4")	F-31870
		25mm (1")	F-31883
		30mm (1-3/16")	F-31896
		32mm (1-1/4")	F-31902
AF506, DBN500, DBN501, FN001G	18Ga Brad Nail (5,000 pcs/box)	35mm (1-3/8")	F-31915
		38mm (1-1/2")	F-31928
AF506, DBN500, DBN501	18Ga Brad Nail (5,000 pcs/box)	40mm (1-9/16")	F-31931
		45mm (1-3/4")	F-31944
		50mm (2")	F-31957

Staple

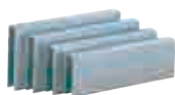

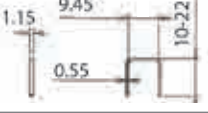
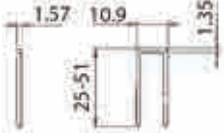
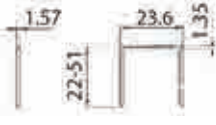
Model No.	Type	Length	Part No.
DST221 	10mm(3/8") Crown Staple (5,040 pcs/box)	10mm (3/8")	F-32647
		13mm (17/32")	F-32650
		16mm (5/8")	F-32663
		19mm (3/4")	F-32676
		22mm (7/8")	F-32689
AT1150A 	7/16" Medium Crown Staple 16Ga (10,000 pcs/box)	25mm (1")	F-32078
		28mm (1-1/8")	F-32081
		32mm (1-1/4")	F-32094
		35mm (1-3/8")	F-32100
		40mm (1-9/16")	F-32113
		45mm (3/4")	F-32126
		51mm (2")	F-32139
AT2550A 	1" Wide Crown Staple 16Ga (10,000 pcs/box)	22mm (7/8")	F-32197
		25mm (1")	F-32023
		32mm (1-1/4")	F-32036
		38mm (1-1/2")	F-32049
		45mm (1-3/4")	F-32052
		51mm (2")	F-32065

Brad Nail fuel cell set

Fuel cell/ carton x2 set



Model No.	Type	Length	Part No.
GF600	16Ga Brad Nail Galvanized (2,000 pcs/box)	15mm	195667-8
		19mm	195668-6
		22mm	195669-4
		25mm	195670-9
		30mm	195671-7
		32mm	195672-5
		35mm	195673-3
		38mm	195674-1
		40mm	195675-9
		45mm	195676-7
		50mm	195677-5
		57mm	195678-3
		60mm	195679-1
	64mm	195680-6	
	16Ga Brad Nail Stainless (2,000 pcs/box)	25mm	195681-4
		38mm	195682-2
		50mm	195683-0
		64mm	195684-8

Concrete pin

Includes one Fuel cell / box.
Box : 10pins/strip x 100 = 1,000pins
for Europe



Model No.	Description	Dia. (mm)	Length	Part No.
GN420C	Premium pin	3.1	15mm	196285-5
			17mm	196286-3
			22mm	196287-1
			27mm	196288-9
			32mm	196289-7
	Standard pin	2.6	20mm	196290-2
			25mm	196291-0
			30mm	196292-8
			35mm	196293-6
			40mm	196294-4

Fastening/ Fixing

Flat Tape Collated Screws

Drywall Screws

Application	L (mm)	Shank Dia (mm)	Recess	Thread	Finish	Screws/- Belt	Screws/- Box	Part No.
Drywall to metal stud (Plasterboard to metal stud)	25	3.5	PH2	Fine	Phosphated	50pcs	1,000pcs	F-31227
	25	3.9	PH2	Fine	Phosphated	50pcs	1,000pcs	F-30913
	30	3.9	PH2	Fine	Phosphated	50pcs	1,000pcs	F-30926
	32	3.5	PH2	Fine	Phosphated	50pcs	1,000pcs	F-31018
	35	3.5	PH2	Fine	Phosphated	50pcs	1,000pcs	F-31230
	35	3.9	PH2	Fine	Phosphated	50pcs	1,000pcs	F-31153
	41	3.5	PH2	Fine	Phosphated	50pcs	1,000pcs	F-32232
	41	3.9	PH2	Fine	Phosphated	50pcs	1,000pcs	F-31166
	45	3.9	PH2	Fine	Phosphated	50pcs	1,000pcs	F-30939
	55	3.9	PH2	Fine	Phosphated	50pcs	1,000pcs	F-30942
Drywall to Steel frame (Plasterboard to Steel frame)	35	3.5	PH2	Fine/Self Drilling	Phosphated	50pcs	1,000pcs	F-31195
Drywall to wood (Plasterboard to wood)	30	3.9	PH2	Coarse	Phosphated	50pcs	1,000pcs	F-30955
	30	3.9	PH2	Coarse	Yellow Zinc (5 micron)	50pcs	1,000pcs	F-32203
	33	3.5	PH2	Coarse	Phosphated	50pcs	1,000pcs	F-31021
	35	3.9	PH2	Coarse	Phosphated	50pcs	1,000pcs	F-31179
	41	3.5	PH1	Coarse	Phosphated	50pcs	1,000pcs	F-31034
	41	3.9	PH2	Coarse	Phosphated	50pcs	1,000pcs	F-31182
	41	3.9	PH2	Coarse	Yellow Zinc (5 micron)	50pcs	1,000pcs	F-32216
	55	3.9	PH2	Coarse	Phosphated	50pcs	1,000pcs	F-31140
Drywall to wood (Plasterboard to hard wood)	30	3.9	PH2	Hi-Low	Yellow Zinc (5 micron)	50pcs	1,000pcs	F-32245
	41	3.9	PH2	Hi-Low	Yellow Zinc (5 micron)	50pcs	1,000pcs	F-32258
	55	3.9	PH2	Hi-Low	Yellow Zinc (5 micron)	50pcs	1,000pcs	F-32261
Chipboard Screws (Particleboard to wood)	30	4.2	PH2	Coarse, Part Thread	Yellow Zinc (5 micron)	50pcs	1,000pcs	F-32528
	42	4.2	PH2	Coarse, Part Thread	Yellow Zinc (5 micron)	50pcs	1,000pcs	F-32531
	55	4.2	PH2	Coarse, Part Thread	Yellow Zinc (5 micron)	50pcs	1,000pcs	F-32544
Fermacell Screws (Gypsum Fibreboard to hard wood)	30	3.9	PH2	Hi-Low	Phosphated	50pcs	1,000pcs	F-31748
	45	3.9	PH2	Hi-Low	Phosphated	50pcs	1,000pcs	F-31751
Hardboard Screws (HDF board to hard wood)	32	3.9	PH2	Hi-Low	Dacromate	50pcs	1,000pcs	F-31793
	41	3.9	PH2	Hi-Low	Dacromate	50pcs	1,000pcs	F-31809
Decking Screws (Wood to wood)	42	4.2	PH2	Coarse, Part Thread	Stainless Steel	50pcs	1,000pcs	F-32470
	55	4.2	PH2	Coarse, Part Thread	Stainless Steel	50pcs	1,000pcs	F-32483
Wood Screws (Playwood to hard wood)	40	4.2	PH2	Hi-Low	Zinc Plated	50pcs	1,000pcs	F-31201
	55	4.2	PH2	Hi-Low	Zinc Plated	50pcs	1,000pcs	F-31214
Wood Screws (Wood to wood)	45	4.2	SQ2	Coarse	Yellow Zinc	50pcs	1,000pcs	F-33205
	50	4.2	SQ2	Coarse	Yellow Zinc	50pcs	800pcs	F-33218
Wood Screws (Wood to wood)	41	4.2	SQ2	Coarse	Geomet	50pcs	1,000pcs	F-33276
	45	4.2	SQ2	Coarse	Geomet	50pcs	1,000pcs	F-33289
	50	4.2	SQ2	Coarse	Geomet	50pcs	800pcs	F-33292
	63	4.2	SQ2	Coarse	Geomet	50pcs	600pcs	F-33324
	75	4.2	SQ2	Coarse	Geomet	50pcs	600pcs	F-33340

	For Model								Autofeed attachment set	For Model				Part No.
	DFR440	DFR540	DFR550	DFR750	6842	6843	6844	6845		DFR452	DFR453	DFR551	DFR552	
	25-41mm	25-55mm	25-55mm	45-75mm	25-55mm	25-55mm	45-75mm	25-41mm		25-55mm	20-41mm	20-41mm	25-55mm	
Yes		Yes						Yes	Yes	Yes	Yes	Yes	F-31227	
Yes	Yes	Yes			Yes	Yes	Yes	Yes	Yes	Yes	Yes	Yes	F-30913	
Yes	Yes	Yes			Yes	Yes	Yes	Yes	Yes	Yes	Yes	Yes	F-30926	
Yes	Yes	Yes			Yes	Yes	Yes	Yes					F-31018	
Yes		Yes						Yes	Yes	Yes	Yes	Yes	F-31230	
Yes	Yes	Yes			Yes	Yes	Yes	Yes	Yes	Yes	Yes	Yes	F-31153	
Yes	Yes	Yes			Yes	Yes	Yes	Yes	Yes	Yes	Yes	Yes	F-32232	
Yes	Yes	Yes			Yes	Yes	Yes	Yes	Yes	Yes	Yes	Yes	F-31166	
Yes	Yes		Yes	Yes	Yes			Yes			Yes	Yes	F-30939	
Yes	Yes	Yes	Yes	Yes	Yes			Yes			Yes	Yes	F-30942	
Yes		Yes						Yes	Yes	Yes	Yes	Yes	F-31195	
	Yes	Yes			Yes	Yes		Yes	Yes	Yes	Yes	Yes	F-30955	
Yes	Yes	Yes			Yes	Yes	Yes	Yes	Yes	Yes	Yes	Yes	F-32203	
Yes	Yes	Yes			Yes	Yes	Yes						F-31021	
Yes	Yes	Yes			Yes	Yes	Yes	Yes	Yes	Yes	Yes	Yes	F-31179	
Yes	Yes	Yes			Yes	Yes	Yes						F-31034	
Yes	Yes	Yes			Yes	Yes	Yes	Yes	Yes	Yes	Yes	Yes	F-31182	
Yes	Yes	Yes			Yes	Yes	Yes	Yes	Yes	Yes	Yes	Yes	F-32216	
	Yes				Yes	Yes	Yes	Yes			Yes	Yes	F-31140	
	Yes	Yes	Yes	Yes	Yes	Yes	Yes	Yes			Yes	Yes	F-32229	
Yes	Yes	Yes			Yes	Yes	Yes	Yes	Yes	Yes	Yes	Yes	F-32245	
Yes	Yes	Yes			Yes	Yes	Yes	Yes	Yes	Yes	Yes	Yes	F-32258	
	Yes	Yes	Yes	Yes	Yes	Yes	Yes	Yes			Yes	Yes	F-32261	
Yes	Yes	Yes			Yes	Yes	Yes	Yes	Yes	Yes	Yes	Yes	F-32528	
	Yes	Yes			Yes	Yes		Yes			Yes	Yes	F-32531	
	Yes	Yes	Yes	Yes	Yes	Yes	Yes	Yes			Yes	Yes	F-32544	
Yes	Yes	Yes			Yes	Yes	Yes	Yes	Yes	Yes	Yes	Yes	F-31748	
Yes	Yes	Yes	Yes	Yes	Yes	Yes		Yes					F-31751	
Yes	Yes	Yes			Yes	Yes	Yes	Yes	Yes	Yes	Yes	Yes	F-31793	
Yes	Yes	Yes			Yes	Yes	Yes	Yes	Yes	Yes	Yes	Yes	F-31809	
	Yes	Yes			Yes	Yes		Yes			Yes	Yes	F-32470	
	Yes	Yes	Yes	Yes	Yes	Yes	Yes	Yes			Yes	Yes	F-32483	
Yes	Yes	Yes			Yes	Yes	Yes	Yes	Yes	Yes	Yes	Yes	F-31201	
	Yes	Yes	Yes	Yes	Yes	Yes	Yes	Yes	Yes	Yes	Yes	Yes	F-31214	
	Yes	Yes	Yes	Yes	Yes	Yes	Yes		Yes	Yes	Yes	Yes	F-33205	
	Yes	Yes	Yes	Yes	Yes	Yes	Yes						F-33218	
Yes	Yes	Yes			Yes	Yes		Yes					F-33276	
	Yes	Yes	Yes	Yes	Yes	Yes	Yes	Yes					F-33289	
	Yes	Yes	Yes	Yes	Yes	Yes	Yes	Yes					F-33292	
			Yes			Yes							F-33324	
			Yes			Yes							F-33340	

For Dust Collecting *for Model DVC265, DVC665, VC009G, VC012G only

Model VC006GM VC007GL 	Model VC002GL VC004GL DVC157L DVC867L 	Model VC3211H VC3211M VC2211M VC3210L VC2510L VC1310L 	Model VC009G VC012G DVC265 DVC665 DVC350 	Model VC013GL VC014GL DVC750L 	Model VC3012L/M VC4210L/M 	Model VC2012L VC2512L VC3011L 
---	---	---	---	---	---	--

Hose 28mm **Mesh sleeve hose 1.0m *143787-2 without front cuffs 1.5m A-34235 with front cuffs 22, 38 2.5m 195437-5 with front cuffs 22, 24, 38 3.5m 195433-3 with front cuffs 22, 24, 38 5.0m 191G76-1*1 with front cuffs 22, 24, 38 5.0m A-34229 with front cuffs 22, 38	Hose 38mm with front cuffs 38 1.5m 198757-6 2.5m 195434-1 5.0m 195435-9	Hose 38mm with front cuffs 38 5.0m 191Y12-5	Hose 28mm with front cuffs 22, 24, 38 5.0m 1915G6-9	32-B Hose 32mm 4m P-84084	32-B Hose 32mm 3.5m P-81739
---	--	--	--	-------------------------------------	---------------------------------------

Front cuffs Front cuffs 38 195545-2 Front cuffs 22 195547-8	Front cuffs 24 195546-0	Joint 22-38 195548-6	Front cuffs 24 195546-0	Front cuffs Front cuffs 38 195545-2 Front cuffs 22 195547-8	Tool adaptor Quicksystem ø24 (set) P-70378 Quicksystem ø38 (set) W107418688	Tool adaptor 24 D-81745
--	-----------------------------------	--------------------------------	-----------------------------------	--	--	-----------------------------------









Auto-start Wireless System

Wireless unit adapter
WUT02
 Converts tool-triggered AC vacuum cleaners in the market into AWS-compatible vacuum cleaners



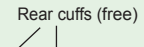

Tool connection cuffs and hoses

Hose 28mm Supplied with both front cuffs 22 and 38 	Rear cuffs (free) 	Screw-in type, replaceable Front cuffs 38: Inner dia. 38.0mm, Outer dia. 44.2mm Front cuffs 22: Inner dia. 22.4mm, Outer dia. 25.0mm
Hose 38mm 	Rear cuffs (free) 	Front cuffs are attached to the hose Front cuffs 38: Inner dia. 38.0mm, Outer dia. 44.2mm

How to connect front cuffs 22, 38 to front cuffs 24

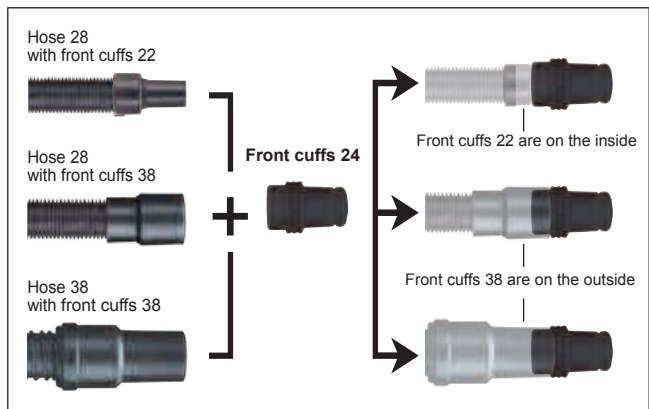

Connection of hose 38mm from front cuff 38 to front cuff 22

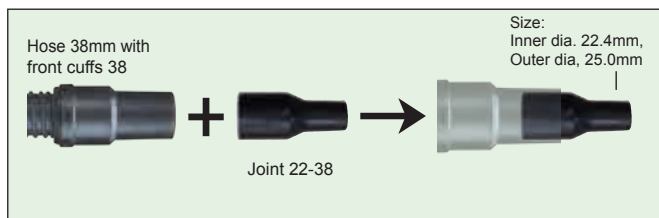

Hose to hose connection

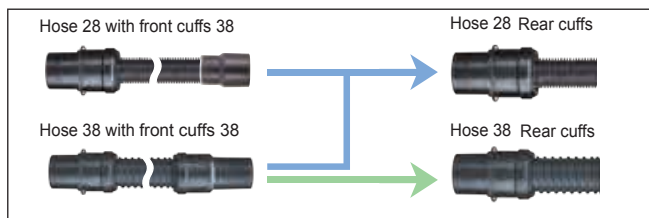

Vacuum attachment for hammer drilling, chiselling

Still photo	Name	Related models	Connected cuff size mm	Operation mode	Part No.		
	Dust collector set	HR1841F		Drilling	193472-7		
	Dust cup set	DHR171, HR140D, HR166D, HR1840, HR1841F	22	All	198362-9		
		DHR183, HR010G		Drilling	1911P8-4		
		DHR280, DHR282, HR008G, HR2300, HR2600, HR2601, HR2631F		All	195173-3		
		DHR281, DHR283, HR009G, HR2320T, HR2631FT			195179-1		
				Drilling	1914L7-6		
		HR011G, HR2670		Chiselling	1914L9-2		
				Drilling	1914L8-4		
		HR012G, HR2670FT		Chiselling	1914M0-7		
		Dust extractor attachment set		HR005G, HR4003C, HR4013C	24, 38	-	199142-6
				HR005G, HR4013C	22, 38	-	199014-5
	HR006G		22	Drilling / hammering	191N81-0		
					191N82-8		
	HR4002, HR4501C, HR4510C, HR4511C		Hose 28 without cuffs	-	196074-8		
	HR4002, HR4510C, HR4511C		22	-	196116-8		
	HR5202C, HR5212C			Drilling / hammering	196858-4		
	Dust extraction pad set		All Rotary hammer	22, 24	Drilling	1914X3-8	

Still photo	Name	Related models	Connected cuff size mm	Operation mode	Part No.					
	Dust extractor attachment set	HM001G, HM002G, HM0830, HM0870C, HM0871C, HM1101C, HM1111C, HM1203C, HM1205C, HM1213C, HM1214C, HR005G, HR006G, HR3530, HR3540C, HR3541FC, HR4002, HR4003C, HR4013C, HR4030C, HR4041C, HR4501C, HR4510C, HR4511C, HR5202C, HR5212C	Hose 28 without cuffs	Hammering	199143-4					
		HM001G, HM002G, HM0870C, HM0871C, HM1111C, HM1203C, HM1213C, HM1214C, HR005G, HR006G, HR4002, HR4003C, HR4013C, HR4041C, HR4501C, HR4510C, HR4511C			199017-9					
		HR005G, HR006G, HR4002, HR4003C, HR4013C, HR4041C, HR4510C, HR4511C			199019-5					
		HM1306, HM1307C, HM1307CB, HM1317C, HM1317CB, HM1802, HM1812			22	Drilling / hammering	197148-8			
		HM1307C, HM1307CB, HM1317CB, HM1812			Hose 28 without cuffs	-	197168-2			
							197170-5			
		Dust extractor attachment set			HM1501, HM1502, HM1511, HM1512	22, 24, 38	Drilling / hammering	197172-1		
								24, 38	-	191M20-4
								Hose 28 without cuffs	-	191M21-2
								24, 38	-	191M22-0
		Hose 28 without cuffs	-	191M23-8						





Vacuum adapter for sawing

Still photo	Name	Related models	Connected cuff size mm	Part No.		
	Dust attachment set	DTM53	22	1916E5-3		
	Dust nozzle set	DHS630	24	194314-8		
		DSS501		194415-2		
		HS300D, HS301D		195334-5		
		5007MG, 5007MGA, 5007N, 5007NF		199716-3		
		5007MG, 5007N, 5007NF		199968-6		
		5007N, 5007NF		199712-1		
		5007NB		199711-3		
		DHS660, DHS661		199230-9		
		DHS680		196952-2		
		DHS680, HS012G		196961-1		
		DHS710, DHS780, DHS781, DHS782, DHS783, HS003G, HS004G, HS6600, HS6601, HS7000, HS7010, HS7600, HS7601, HS7610, HS7611		196520-1		
		HS0600		198263-1		
		HS7000, HS7600		198265-7		
		HS7010, HS7610, HS7611		197221-4		
		HS7010, HS7610, HS7611		198933-2		
		Dust nozzle assembly set		LS1019, LS1019L	-	191D03-0
		Hose joint assembly set		DLS110, DLS111, DLS112, LS1219, LS1219L	-	191D04-8
		Dust nozzle set		5008MGA	38	1915M2-9
						194489-3
		Joint set		5143R		192490-2



Still photo	Name	Related models	Connected cuff size mm	Part No.
	Joint set	5902B, N5900B	38	193068-4
				193823-4
		5903R		192419-8
		HS013G		199427-0

Dust collection wheel guard



Still photo	Name	Related models	Connected cuff size mm	Part No.
	Dust collect cover set (125MM)	9555HN, 9558HN, 9558HNR, 9558HP, 9565C, 9565CV, 9565PC, 9565PCV, GA5020, GA5020C, GA5021C	38	196846-1
	Dust collect cover K set (125MM)	9565CR, DGA514, GA5040, GA5040C		196845-3
	Dust collect cover set 125mm	DGA519, DGA520, DGA521, GA039G, GA040G, GA041G, GA042G, GA043G, GA044G, GA045G, GA046G, GA047G, GA5080, GA5080R		191G05-4
	Dust collect cover K set (180MM)	DGA700, DGA701, GA037G, GA7050, GA7050R, GA7060, GA7061, GA7061R, GA7070, GA7080, GA7081		198514-2
	Dust collect cover K set B (230MM)	DGA900, DGA901, GA038G, GA9060R, GA9081		198510-0
	Wheel cover set	9500NB, N9500N		192212-0
	Wheel cover 100C set	9553HN, 9556HN, 9556HP, DGA402, GA4031, GA4032, GA4034		198413-8
	Wheel cover 100CD set	9556HN, 9556HP, DGA404, DGA405, DGA406, DGA408, DGA411, DGA413, DGA414, DGA417, DGA418, GA4030, GA4030R, GA4031, GA4032, GA4034, GA4040, GA4040C		198414-6
	Wheel cover 125C set	9554HN, 9555HN, 9557HN, 9557HP, 9558HN, 9558HP, 9564CV, 9564P, 9565C, 9565CV, DGA452, GA5010, GA5020, GA5021C, GA5041C, PC5010C	22	198415-4
	Wheel cover 125CD set	9557HNR, 9558HNR, 9564P, 9565PC, DGA452, DGA454, DGA455, DGA456, DGA458, DGA463, DGA467, DGA504, DGA505, DGA506, DGA508, DGA511, DGA512, DGA513, DGA514, DGA517, DGA518, GA4530, GA4530R, GA4534, GA5010, GA5011, GA5020, GA5030, GA5030R, GA5034		198416-2
	Wheel cover 180 set	GA7020		194303-3
	Wheel cover set	GA7030, GA7040S, GA9020, GA9030, GA9040S	38	194044-1

Still photo	Name	Related models	Connected cuff size mm	Part No.
	Dust cover K set 115/125mm	9557HNR, 9558HNR, 9564CV, 9564P, 9564PC, 9564PCV, 9565C, 9565CR, 9565CV, 9565HR, 9565PC, 9565PCV, DGA454, DGA455, DGA456, DGA458, DGA463, DGA467, DGA504, DGA505, DGA506, DGA508, DGA511, DGA512, DGA513, DGA514, DGA517, DGA518, GA4540, GA4540C, GA4540R, GA5020, GA5020C, GA5021, GA5021C, GA5040, GA5040C, GA5040R, GA5041C, PC5010C	38	191W06-8
	Dust cover K set 115/125mm	9564CV, 9564P, 9564PC, 9564PCV, 9565CV, 9565PC, 9565PCV, DGA454, DGA455, DGA504, DGA505, DGA506, DGA508, DGA511, DGA512, DGA513, DGA514, DGA517, DGA518, GA4542C, GA5020, GA5020C, GA5040, GA5042C, PC5010C		1911K3-9
	Dust cover set 115/125mm	GA004G, GA005G, GA007G, GA008G, GA012G, GA013G, GA015G, GA016G, GA022G, GA023G, GA025G, GA026G, GA028G, GA029G, GA4550R, GA4590, GA4591, GA4592, GA4593, GA4594, GA4595, GA5050R, GA5090, GA5091, GA5092, GA5093, GA5094, GA5095		191W05-0
	Dust cover set 115/125mm	GA005G, GA013G, GA023G, GA029G, GA4552R, GA4590, GA4591, GA4595, GA5052R, GA5090, GA5091, GA5092, GA5093, GA5095		1911K2-1
	Dust collect cover K set 180mm	DGA700, DGA701, DGA900, DGA901, GA037G, GA038G, GA7010C, GA7012C, GA7020S, GA7030R, GA7040S, GA7050R, GA7061, GA7061R, GA7070, GA7080, GA7081, GA9010C, GA9012C, GA9020R, GA9020S, GA9030R, GA9030S, GA9040R, GA9040S, GA9050R, GA9060R, GA9061R, GA9062R, GA9070, GA9071, GA9080, GA9081, DGA700, DGA701, DGA900, DGA901, GA038G, GA7010C, GA7040S, GA7061, GA7061R, GA7070, GA7080, GA7081, GA9040S, GA9060R, GA9061R, GA9070, GA9080, GA9081	38	191X44-6
				1911K1-3
	Dust collect cover set (115/125MM)	9564P, 9564PC, 9564PCV, 9565PC, 9565PCV, GA5020, 9565C, GA5021C	38	195236-5
	Dust collect cover K set (115/125MM)	9557HNR, 9558HNR, 9564P, 9564PC, 9564PCV, 9565C, 9565CR, 9565HR, 9565PC, GA4540, GA4540C, GA4540R, GA5020, GA5020C, GA5021C, GA5040, GA5040C, GA5040R, GA5041C		195237-3
	Dust collect cover set 125mm	GA004G, GA005G, GA007G, GA008G, GA013G, GA016G, GA022G, GA023G, GA025G, GA026G, GA028G, GA029G, GA4550R, GA5050R		195239-9
	Dust collect cover set (180MM)	GA7040S	38	191F81-2
	Dust collect cover K set (180MM)	DGA700, DGA701, DGA900, DGA901, GA037G, GA038G, GA7070, GA7080, GA7081, GA9020R, GA9030R, GA9040R, GA9060R, GA9061R, GA9070, GA9071, GA9080, GA9081		195386-6
-	Dust collect cover K set 125mm	PC5010C		195385-8
				191S70-5

Vacuum adapter for grinding, sanding

Still photo	Name	Related models	Connected cuff size mm	Part No.
	Dust cover set	9032, DBS180	-	191N60-8
	Joint 25 set	9032, 9046, 9403, BO4900, BO4900V, BO4901, BO5030, BO5031, BO5040, BO5041, DBO180, DBS180, DHR202, DHR263, DHR264, HR2475, HR2800, HR2810, HR2810T, HR2811F, HR2811FT, RP0910, RP1111C	38	192349-3
	Joint 32 set	9924DB		192518-6

Dust cover, protector for polisher, sander

Still photo	Name	Related models	Connected cuff size mm	Part No.
	Dust collect cover set	PK5011C	38	195774-7
	Dust cover set	PW5000C, PW5001C	-	194233-8
	Protector set	PK5011C		196028-5

Dust cover for cutter

Still photo	Name	Related models	Connected cuff size mm	Part No.
	Dust cover set	DCC501	38	191N83-6

Vacuum adapter for cutting

Still photo	Name	Related models	Connected cuff size mm	Part No.
		DTM50	22	199621-4
		TM3000C		199618-3
	Dust attachment set	TM3010C		199624-8
		TM30D		199630-3
	Dust extractor attachment set	DTM52, TM001G	22	191R02-6
	Elbow joint 32 set	4114, 4114S	38	192613-2

Cleaning

Vacuum adapter for milling, planing

Still photo	Name	Related models	Connected cuff size mm	Part No.
	Dust collect cover set	3706, DCO180, DCO181	22	193449-2
	Dust nozzle set	DRT50, RP0900, RT001G, RT0700C, RT0702C	38	194733-8
		DRT50, RT001G, RT0700C, RT0702C		195559-1
		RF1101		193379-7
		RP001G, RP1800, RP1800F, RP1802, RP1802F, RP1803, RP1803F, RP2300FC, RP2301FC, RP2302FC, RP2303FC		194934-8
	Elbow set	DKP181, KP001G		191C20-4
	Nozzle for vacuum cleaner	1911B	38	192082-7
	Nozzle set	KP312, KP312S	70	193733-5

Hood set

Still photo	Name	Related models	Inner diameter of connected hose mm	Part No.
	Hood set	2012NB	75	193036-7





Vacuum connector

Still photo	Name	Related models	Part No.
	Joint A32 set	Adapter for connecting Straight Pipe 28 to a third-party vacuum cleaner nozzle	PACVAC SHOPVAC Proteam 191M77-5
	Joint B35 set		KARCHER Nilfisk 191M78-3
	Joint C38 set		Proteam Side Winder 191M79-1
	Front cuff 38 set	Attached to hose 28, for model that require Cuff 38	195545-2
	Front cuff 22 set	Attached to hose 28, for model that require Cuff 22	195547-8
	Joint 22-38 set	Attached to cuff 38, for model that require Cuff 22	195548-6
	Front cuff 24 set	Attached to cuff 22 or 38, for model that require Cuff 24	195546-0
	Holder cuff set	Front cuff 22, Front cuff 24 and Holder 10-33 set	195637-7
	Tool adapter with regulation	VC2012L, VC2512L, VC3011L	P-81745
	Tool adaptor 22 quick set	VC2000L, VC2012L, VC2512L, VC3011L	W107418661
	adapter 35/38	VC3012L/M, VC4210L/M, VC2012L, VC2512L, VC3011L	P-70421
	Tool adaptor 38	VC2012L, VC2512L, VC3011L	W107418680
	Quicksystem ø24 (set)	VC3012L/M, VC4210L/M	P-70378
	Quicksystem ø38 (set)		W107418688
	Tool cuff adapter 24		P-70415
	Tool cuff adapter 38		P-70421

Filter & bag

Name	Per pkg.	Related models	Part No.
Fleece filter bag (Filter bag)	5	VC2000L, VC2012L, VC3011L, VC2512L,	P-72899
Pre Disposal bag	5		P-70297
PTFE Flat filter	1	VC4210M / L	W107418351
Motor cooling filter PET	1		W107418352
Fleece filter bag (Filter bag)	5		W107418353
Long-Life Filter bag	1		W107418354
Pre Disposal bag	5		W107418355
PET Filtecent	1	VC2512L, VC3011L, VC3012M / L	P-70219
Fleece Filter bags	5	VC2512L, VC3011L, VC3012M / L	P-84078
Pre Disposal bag	5		P-70297

Vacuum kit

Still photo	Name	Related models	Part No.
	Vacuum kit set	DUB363	191E19-1
			191E20-6
			191P37-5
			191P38-3
-	-	UB003G	1916T9-0

Dust bag for blower, cleaner

Still photo	Name	Related models	Part No.
	Dust bag set	DUB363	191P40-6



Adapter

Still photo	Name	Related models	Reference	Part No.
	Adapter pipe 104-72 set	UB002C	104-72	1910M7-9
	Adapter pipe 71 set	DUB362, DUB363	71	191J13-3
	Adapter pipe 80-72 set	DUB184	80-72	191L13-5
	Adapter pipe 85-72 set	UB001C, UB001G, UB003C	85-72	191L96-5
	Adapter pipe set MG	UB400MP, UB401MP	80-72	191C15-7



Nozzle for blower, cleaner

Still photo	Name	Related models	Hose length m	Part No.
	Anchor nozzle set	DUB185, DUB186, UB100D, UB101D, UB1102, UB1103	-	192236-6
	Bending long nozzle set			196729-5
	Garden nozzle assembly set			191G09-6
	Extension nozzle set	DUB184, DUB362, DUB363, UB001C, UB001G, UB002C, UB003C	-	197888-8
	Flat nozzle set			197889-6
	Gutter nozzle set	DUB184, DUB362, DUB363, UB001C, UB001G	2.9	191B03-8
	End nozzle 74 set	UB004C	-	1914H0-2
	Flat nozzle set	UB004C		1914H1-0
	Flat nozzle set	UB003G		1916V7-8
	End nozzle 80 set	UB001C, UB001G		191P97-7
	T shape vacuume nozzle assy	DUB187	-	GB00000165
	Water blowing nozzle set	DUB184	-	1915C8-7

Hose for blower, cleaner

Still photo	Name	Related models	Hose length m	Part No.
	Flexible hose set	DUB185, DUB186, UB100D, UB101D	-	191M34-3
		DUB185, DUB186, UB100D, UB101D, UB1102, UB1103	0.95	196643-5

Harness, belt

Still photo	Name	Related models	Part No.
	Band 25 set	PM001G, UB002C	196733-4
	Band assembly set	UB001C	191J48-4

with front sleeve



























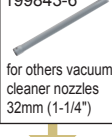















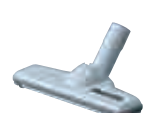





28mm Tip attachments

32mm Tip attachments

For Cleaning

*for Model DVC261, DVC265, DVC660, DVC665, VC008G, VC009G, VC011G, VC012G only

Color

<p>Model VC006GM DVC156L VC007GL DVC860L VC001GL DVC861L VC003GL DVC865L VC005GL DVC866L DVC155L</p> 	<p>Model VC3211H VC3211M VC2211M VC3210L VC2510L VC1310L</p> 	<p>Model VC008G VC011G DVC261 DVC660 DVC350</p> 			
<p>Hose 38mm with front sleeve (front cuffs 32A) 1.5m 199388-4</p> 	<p>Hose 32mm with front sleeve 1.0m*199453-9 1.7m 199493-7</p> 	<p>Hose 28mm 1.0m 195433-3 *143787-2 5.0m 195436-7 1.5m A-34235 5.0m A-34229 2.5m 195437-5</p> 			
<p>Bending pipe assembly with pipe lock without sleeve 140G26-3 (front cuffs 32A) </p> <p>Bending pipe assembly with pipe lock with sleeve 127093-3 </p> <p>Bending pipe assembly without sleeve 458184-2 (front cuffs 32A) </p> <p>Bending pipe assembly with sleeve 126756-8 </p>	<p>Bending pipe & Telescopic pipe set without sleeve Aluminum pipe 191B15-1 Plastic pipe 191G89-2</p> 		<p>Front cuffs 22 195547-8 </p>		
<p>Cyclone attachment set with pipe lock* ○ 191D71-3 / 191D70-5 ● 191D73-9 / 191D72-1 </p>	<p>Cyclone attachment set* ○ 199491-1 / 191D74-7 ● 191D75-5 / 199553-5 </p>		<p>Aluminum Telescopic pipe (L=591-43mm) 191X62-4 </p> <p>for others vacuum cleaner nozzles 32mm (1-1/4")</p>	<p>Aluminum joint pipe (L=465mm) 199844-4 </p> <p>Aluminum straight pipe 32 (L=465mm) 199843-6 </p> <p>for others vacuum cleaner nozzles 32mm (1-1/4")</p>	<p>Tapered nozzle set 192236-6 </p>
<p>Straight pipe with pipe lock Aluminum Telescopic pipe 28L (L=590-942mm) 199633-7 Bending pipe assembly with pipe lock (140G26-3) set 191B15-1</p> <p>Plastic Telescopic pipe 28L (L=590-950mm) 127605-2 </p> <p>Plastic straight pipe 28L with pipe lock (L=479mm) ○ 459353-8 ● 459356-2 ● 458942-6 </p> <p>Plastic straight pipe 28L with pipe lock (L=340mm) for Cyclone attachment set ○ 191D76-3 ● 191D77-1 </p>	<p>Straight pipe Plastic Telescopic pipe 28 (L=500-850mm) 198560-5 </p> <p>Plastic straight pipe 28 (L=465mm) ○ 451424-7 ○ 451241-5 ● 451244-9 ● 456587-4 </p> <p>Plastic straight pipe 28 (L=320mm) for Cyclone attachment set ○ 191D79-7 ● 191D80-2 </p>		<p>F/C switching t-nozzle 32 1912F9-8 </p>	<p>Rotary brush nozzle set 32 1914Y7-7*1 </p>	
<p>28mm Tip attachments</p> <p>Rotary brush nozzle set 28 Carpet 1914Y6-9*1 </p> <p>Nozzle assembly Flat type 199454-7 </p> <p>F/C switching t-nozzle 28 Flooring & carpet 191G86-8 </p> <p>Nozzle assembly Floor t-nozzle 28 ○ 127825-8 ● 127827-4 ● 127828-2 </p> <p>Nozzle assembly Floor/carpet t-nozzle 28 ○ 191X06-4 </p>	<p>F/C switching t-nozzle 28 Flooring & carpet ○ 198183-9 ● 199431-9 </p> <p>Nozzle assembly Floor t-nozzle 28 ○ 123485-4 ○ 123486-2 ● 123488-8 ● 123539-7 </p> <p>Floor/carpet t-nozzle For rug / carpet ○ 198149-9 ○ 198528-1 ● 198527-3 ● 198529-9 </p> <p>Nozzle assembly For rug / carpet 122291-4 </p> <p>Hard floor nozzle assembly set Backpack Vacuum Cleaner only 1911J4-0 </p>	<p>Seat nozzle 28 For automobile seat ○ 199038-1 ● 199041-2 ● 199039-9 </p> <p>Seat nozzle 120 set For automobile seat 140H95-0 </p> <p>Mat nozzle 120 For automobile floor 459056-4 </p> <p>Brush nozzle set 191M30-1 </p> <p>Sash nozzle ○ 413770-6 ○ 413859-0 ● 413809-5 </p> <p>Long sash nozzle 330 ○ 198919-6 ● 198990-0 ● 198992-6 ● 191D65-8 </p> <p>Crevice nozzle 415 199439-3 </p>	<p>Round brush ○ 198552-4 ○ 198878-4 ● 198553-2 ● 198555-8 </p> <p>Shelf brush ○ 198537-0 ○ 198873-4 ● 198538-8 ● 198540-1 </p> <p>Soft brush 360 complete set 140H94-2 </p> <p>Angle attachment set 1914A7-9 </p>	<p>Rubber nozzle 330 set *422437-5 </p> <p>Flexible rubber nozzle 28 *197901-2 </p>	

*1 Brush complete set (replacement brush) 1915W7-9

Model VC006GM VC007GL VC001GL VC003GL VC005GL DVC155L DVC156L DVC860L DVC861L DVC865L DVC866L		Model VC3211H VC3211M VC2211M VC3210L VC2510L VC1310L		Model VC008G VC011G DVC261 DVC660 DVC350	
---	---	--	---	--	--

Cleaning set

- Hose complete 38-2.5
- Straight pipe
- Bending pipe
- Nozzle assembly
- Corner nozzle

195439-1



Hose 38mm

- 1.5m 198757-6
- 2.5m 195434-1
- 5.0m 195435-9



Bending pipe assembly 38

1912G5-3



Bent pipe
192562-3

Straight pipe
192563-1











Aluminum Telescopic pipe 38

L=606-958mm
1912G4-5



38mm Tip attachments

Nozzle assembly Flat type (Dry) 199455-5		Universal type (Dry/ Wet) 195551-7		Wide Type (Wet model only) A-47846	
F/C switching t-nozzle 38 Flooring & carpet (Dry) 191G87-6		Compact type A (Dry) 195549-4		Round brush (Dry) 191657-9	
F/C switching t-nozzle Flooring & carpet (Dry) 198184-7 / 198533-8		Compact type B (Wet model only) 195550-9		Corner nozzle (Dry) 410306-2	

Model
 VC3012L
 VC4210L
 VC3012M
 VC4210M



Model
 VC2012L
 VC2512L
 VC3011L



Model
 DCL184
 CL121D



Hose 32mm

4m
P-84084



Hose 32mm

3.5m
P-81739



Curved hand tube inox
P-70346

A



Extension tubes
 ø35x520mm black 2 pcs
 P-72942



Extension tubes
 ø35x350mm 3pcs
 W107418350

B



Floor nozzle
 D36x260
 (Dry/ Wet)
 W107402706



Floor nozzle
 D36x300(Dry/ Wet)
 P-81789

C



Floor nozzle
 Universal Type(Wet)
 W000014295



Corner nozzle
 ø35x300
 W6084

D



Corner nozzle
 ø35x200
 Use with P-81745
 W000029541

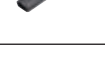

Cleaning set
 A, B, C, D set
 W107418349



28mm Tip attachments



Flexible rubber nozzle 28

197901-2



Blower nozzle complete

140J64-3



Cleaning



for Dust
(Powder)

for
Wet & Dry

Compatible with usual Poly bags or
Paper filters, allowing for:



- Quick and easy dust disposal
- Lower-running cost compared with paper dust bag



	VC006GM, VC007GL (Wet & Dry)	VC001GL, VC003GL (Wet & Dry)	VC002GL, VC004GL VC005GL (Dry)	DVC155L, DVC865L, DVC860L (Wet & Dry)	VC3211H, VC3211M VC2211M, VC2201M (Wet & Dry)	VC3210L, VC2510L (Wet & Dry)	VC1310L (Wet & Dry)	
Use as a set	Powder filter set Dry only *HEPA filter for Dry use only	1911B6-0 *1911B7-8 	*191V70-3 	*191V70-3 	*197166-6 	VC3211H: *196251-2 VC3211M, VC2211M VC2201M: *196252-0 	195441-4 *191F82-0 	195438-3
	Damper set	1911B4-4 	191V68-0 	191V68-0 	195552-5 	196254-6 	195552-5 	195552-5
	Pre-filter set	1911B5-2 	191V69-8 	191V69-8 	195553-3 	196253-8 	VC3210L: 195612-3 VC2510L: 195554-1 	195553-3
Cloth filter Wet & Dry		144625-1 	144625-1 191V71-1 VC005G only 	140248-3 191G88-4 DVC156L, DVC866L only 				
Water filter Wet only It is recommended using water filter when picking up large amount of water repeatedly.	1910N0-0 	191V67-2 		195555-9 DVC155L, DVC865L, DVC860L only 		VC3210L: 195611-5 VC2510L: 195556-7 	195555-9 	
Dust paper filter (5pcs) for dry powder		10L: A-48430	10L: A-48430	7L: A-49541 10L: A-48430 			7L: A-49541 	
Filter bag set 10L/15L/25L/35L (5pcs) for dry dust	35L: 1910Y4-9 	10L: 1912R3-4 VC001GL, VC002GL, VC005GL, DVC860L, DVC861, DVC865L, DVC866L, DVC867L 15L: 195557-5 VC003GL, VC004GL, DVC155L, DVC156L, DVC157L		15L: 195557-5 	25L: 195558-3 	25L: 195558-3 VC3210L only 15L: 195557-5 VC2510L only 	15L: 195557-5 	
Poly bag set (10pcs)	1910R3-2 	195432-5 	195432-5 	195432-5 	195440-6 	195440-6 	195432-5 	

To use powder filter, remove the float cage and float by removing the bolts.

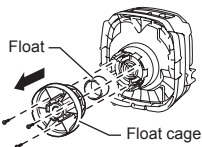

Capacity up tank set

DVC860L, DVC861L, DVC865L, DVC866L, DVC867L
Part No. 191B56-7

"HEPA filter" Mark on tank
DVC861L, DVC863L, DVC864L, DVC866L, DVC867L
Part No. 191B57-5

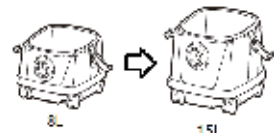

<p>With electric rotary brush</p> <p>CL004G </p>	<p>With pipe lock Model</p> <table border="0"> <tr> <td>CL001G </td> <td>CL114FD </td> </tr> <tr> <td>CL002G </td> <td>CL117FD </td> </tr> <tr> <td>CL003G </td> <td></td> </tr> <tr> <td>DCL283F </td> <td></td> </tr> <tr> <td>DCL284F </td> <td></td> </tr> <tr> <td>DCL285F </td> <td></td> </tr> <tr> <td>DCL286F </td> <td></td> </tr> </table>	CL001G	CL114FD	CL002G	CL117FD	CL003G		DCL283F		DCL284F		DCL285F		DCL286F		<p>Model</p> <table border="0"> <tr> <td>DCL180 </td> <td>CL108FD </td> </tr> <tr> <td>DCL181F </td> <td>CL100D </td> </tr> <tr> <td>DCL182 </td> <td></td> </tr> <tr> <td>CL183D </td> <td></td> </tr> <tr> <td>CL106D </td> <td></td> </tr> <tr> <td>CL107FD </td> <td></td> </tr> </table>	DCL180	CL108FD	DCL181F	CL100D	DCL182		CL183D		CL106D		CL107FD		<p>Model</p> <table border="0"> <tr> <td>CL070D </td> </tr> <tr> <td>CL072D </td> </tr> </table>	CL070D	CL072D
CL001G	CL114FD																														
CL002G	CL117FD																														
CL003G																															
DCL283F																															
DCL284F																															
DCL285F																															
DCL286F																															
DCL180	CL108FD																														
DCL181F	CL100D																														
DCL182																															
CL183D																															
CL106D																															
CL107FD																															
CL070D																															
CL072D																															

<p>Cyclone attachment set with pipe lock</p> <p> 191D71-3 / 191D70-5 191D73-9 / 191D72-1</p>	<p>Dust capsule conv, kit Cyclone unit set</p> <p>Compatible model: CL001G, *CL003G, DCL283F, DCL284F, *DCL286F, DCL180, CL181F (*Standard Equipment)</p> <p> 1910D3-4 1910D4-2 1910D5-0</p>	<p>Cyclone attachment set</p> <p> 199491-1 / 191D74-7(USA) 191D75-5 / *199553-5(USA)</p> <p>*Included sensormatic</p>	<p>Flexible hose set</p> <p> 191496-7 198868-7 198545-1 198547-7</p>
<p>Pipe assembly set For Nozzle assembly set with electric rotary brush</p> <p> 1915P4-6</p> <p>Straight pipe with pipe lock</p> <p> 191D76-3</p> <p>Straight pipe</p> <p> 191D79-7</p>	<p>Flexible hose set</p> <p>191E30-3</p>	<p>Straight pipe</p> <p>Plastic Telescopic pipe 28 (L=500-850mm)</p> <p> 198560-5</p> <p>Plastic straight pipe 28 (L=465mm)</p> <p> 451424-7 451241-5 451244-9 456587-4</p> <p>Plastic straight pipe 28 (L=320mm) for Cyclone attachment set</p> <p> 191D79-7 191D80-2</p>	<p>Straight pipe with pipe lock</p> <p>Plastic telescopic pipe 28L with pipe lock (L=479-719mm) Compatible model: CL001G, CL002G, CL003G, DCL283F, DCL284F, DCL285F, DCL286F 1910Y3-1</p> <p>Plastic straight pipe 28L with pipe lock (L=479mm) 458940-0 459353-8 459356-2 458942-6</p> <p>Plastic straight pipe 28L with pipe lock (L=340mm) for Cyclone attachment set 191D76-3 191D77-1</p>

<p>28mm Tip attachments</p> <p>Nozzle assembly set With electric rotary brush CL004G only 1915P8-8 Brush complete set (replacement brush) 1915P6-2</p> <p>Nozzle assembly Floor t-nozzle 28 127825-8 127827-4 127828-2 127826-6</p> <p>Nozzle assembly Floor/carpet 191X06-4 122B71-0</p> <p>Nozzle assembly Floor t-nozzle 28 123485-4 123486-2 123488-8 123539-7</p> <p>Floor/carpet t-nozzle For rug / carpet 198149-9 198528-1 198527-3 198529-9</p> <p>Nozzle assembly For rug / carpet 122291-4</p>	<p>Seat nozzle 28 For automobile 199038-1 199041-2 199039-9</p> <p>Brush nozzle set 191M30-1</p> <p>Seat nozzle 120 set For automobile 140H95-0</p> <p>Mat nozzle 120 For automobile 459056-4</p> <p>Sash nozzle 413770-6 413859-0 413809-5</p> <p>Long sash nozzle 330 198919-6 198990-0 198992-6 191D65-8</p> <p>Crevice nozzle 415 199439-3</p> <p>Angle attachment set 191A47-9</p>	<p>Round brush</p> <p> 198552-4 198878-4 198553-2 198555-8</p> <p>Shelf brush</p> <p> 198537-0 198873-4 198538-8 198540-1</p> <p>Soft brush 360 complete set 140H94-2</p> <p>Sash nozzle holder 28 For Plastic straight pipe Model: CL001G, CL002G, 459036-0 CL003G, DCL283F, 459354-6 DCL284F, DCL285F, 459355-4 DCL286F, CL114FD, 459038-6 CL117FD</p> <p>CL004G 4132G5-6</p> <p>Others Model 416043-6 451242-3 451245-7 456585-8</p> <p>Plastic straight pipe Sash nozzle holder 28 Sash nozzle</p>	<p>Rubber nozzle 330 set *422437-5</p> <p>*These nozzles cannot be attached directly to Bending pipe assembly use with telescopic pipes or straight pipes.</p>	<p>Holder set Part No. 199971-7 Model: CL001G, CL002G, DCL283F, DCL284F, DCL285F, DCL180, DCL180F, DCL181F, DCL182, DCL182F, CL114FD, CL107FD, CL072D</p>	<p>Cleaner stand set Part No. 1911L1-0 For holding Makita cordless cleaner in an upright position. Model: CL001G, CL002G, CL003G, CL004G, CL070D, CL100D, CL102D, CL106FD, CL107FD, CL108FD, CL111D, CL114FD, CL117FD, CL183D, DCL180, DCL181F, DCL182, DCL283F, DCL284F, DCL285F, DCL286F</p>
---	---	--	---	--	---

Cleaning

Capsule type cleaner

Model: CL001G, DCL283F, DCL284F, DCL181F, DCL180F, DCL180, CL183D, CL108FD, CL106FD, CL070D

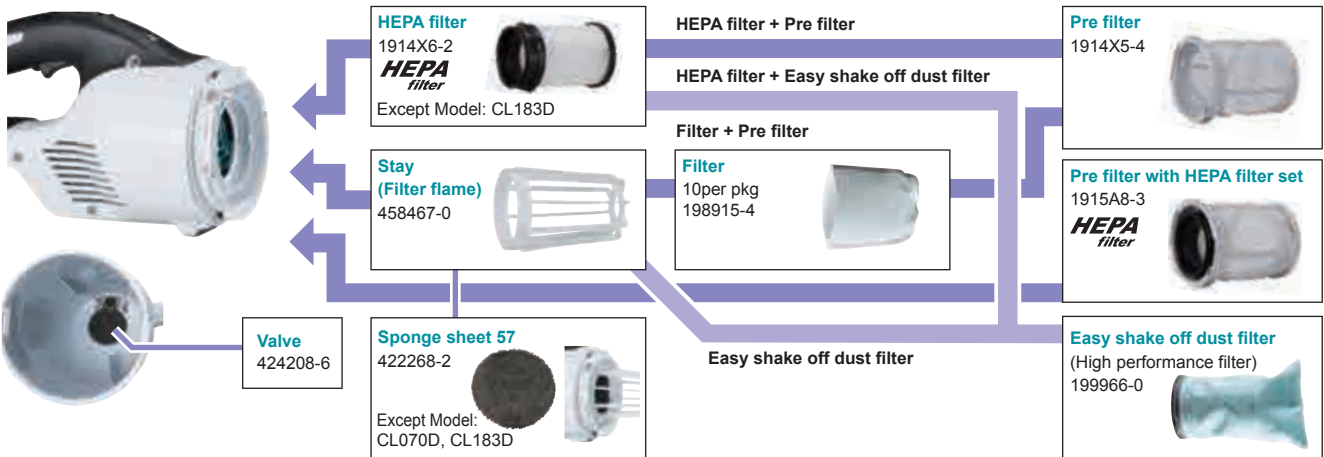

Paper bag type cleaner

Model: CL002G, DCL285F, DCL182, DCL182F, CL114FD, CL121D, CL107FD, CL072D, DCL184, CL121D

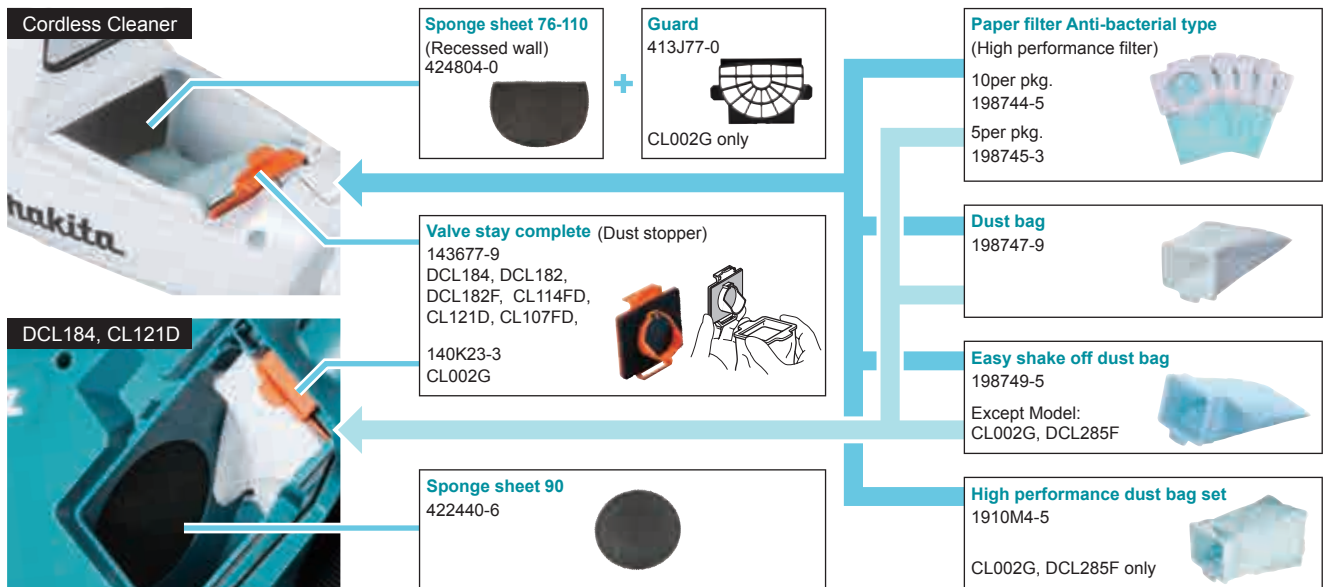

Cyclone unit

Model: CL001G, CL003G, DCL283F, DCL284F, DCL286F

Compatible model:
CL001G, DCL283F, DCL284F, CL003G*,
DCL286F*
*Standard Equipment



Part No. 1910D3-4 Part No. 1910D4-2 Part No. 1910D5-0

Cyclone unit



Cyclone unit filter



HEPA filter *HEPA filter*

Model:
CL004G, CL200FD
1915P2-0
Other Model:
1910C9-5

High performance filter set

Model: CL004G, CL200FD
1915P0-4
Other Model:
1910C7-9
(Standard Equipment)

Cleaner carrying bag

Cleaner body, battery,
charger and
accessories can be
stored together.



Except Model: CL003G, CL004G, DCL286F, DCL184, CL121D
(LxWxH: 600x210x190mm) Part No. 199901-8
with shoulder belt/ Part No. 161904-2

Model: DCL184, CL121D
(LxWxH: 490x210x230mm) Part No. 199900-8
with shoulder belt: Part No. 162544-9

Cordless Upright Cleaner Model: DVC560, VC010G

28mm Tip attachments

Seat nozzle 28
For automobile
○ 199038-1
● 199041-2
● 199039-9

Long sash nozzle 330
○ 198919-6
● 198990-0
● 198992-6
● 191D65-8

Seat nozzle 120 set
For automobile
140H95-0

Crevice nozzle 415
199439-3

Mat nozzle 120
For automobile
459056-4

Round brush
● 198552-4
○ 198878-4
● 198553-2
● 198555-8
● 191D67-4

Brush nozzle set
191M30-1

Shelf brush
● 198537-0
○ 198873-4
● 198538-8
● 198540-1

Sash nozzle
● 413769-1
○ 413770-6
● 413859-0
● 413809-5

Soft brush 360 complete set
140H94-2

Grip assembly set

Dusts can be thrown away by removing Dust case of Cyclone attachment.
1912B1-6

Filter bag set

10pcs. set
191T96-3

Dust bag set

191Y86-6

Main filter h set

191E39-5
HEPA filter

Brush complete set

DVC560: 1910T8-6
VC010G: 1914B1-8

Cordless Portable Vacuum Cleaner Model: DVC750L, VC013GL, VC014GL

For Cleaning & Dust Collecting

Hose Complete
28-2.0m with Front cuffs 38
140G04-3
28-1.5m with Front cuffs 22, 24, 38
1915G6-9
38-1.5m with Front cuffs 38
191Y12-5

Dry only

Wet only

Filter complete (HEPA filter)

Dry 162518-0
HEPA filter

Pre filter and Damper set

Dry only 199827-4

Wet filter set

191M39-3

Shoulder Belt Set

199486-4

38mm Tip attachments

Front cuffs

Front cuffs 38
195545-2
Front cuffs 22
195547-8

Front cuffs 24

195546-0

Joint 38

For Front cuffs 38
418500-0

For Dust Collecting

28mm Tip attachments

Filter bag set

10per pkg.
1915T3-6
VC013GL only

Paper filter bag set

10per pkg.
1915W5-3
VC013GL,
VC014GL only

Poly bag set

10per pkg.
195432-5

Caster Set

1915G5-1
VC013GL, VC014GL

Cleaning

Backpack Vacuum Cleaner Model: VC008G, VC011G, VC012G, VC009G, DVC660, DVC665, DVC261, DVC265

VC011G, VC012G, DVC660, DVC665



- Dust bag assembly**
191C30-1
191Y84-0
(VC012G, DVC660, DVC665)
- Filter bag set (Paper dust bag)**
10per pkg.
191C26-2
- Main filter H set (HEPA filter)**
191D12-9 **HEPA filter**

VC008G, VC009G, DVC261, DVC265



- Dust bag assembly**
197898-5
197899-3(EU)
- Filter bag set (Paper dust bag)**
10per pkg.
197903-8
- Filter set assembly (HEPA filter)** **HEPA filter**
191Y27-2 (VC008G, VC009G)
127725-2 (DVC261, DVC265)

Harness cover set
Washable harness cover made of a mesh material for improved breathability

VC008G, VC009G, VC011G, VC012G, DVC660, DVC665 DVC261, DVC265
191Y14-1



Protection cover set
When using Backpack vacuum cleaner in tight spaces etc., Protection cover is very helpful to prevent the scratches on surrounding objects caused by hitting cleaner.



DVC261, DVC265
1910S4-7

VC008G, VC009G
1911W4-1
1914H7-8*
*For BO001CG series with Battery case





Robotic Cleaner Model: DRC200, DRC300

DRC200





- Side brushes**
SH00000321 (Soft)
SH00000065 (Standard)
- Power brush**
SH00000320 (Soft)
SH00000063 (Standard)
SH00000319 (Combination)
- Boundary line tape (15m roll)**
SH00000231(EU)
SH00000240 (USA, AU)
- Turn brush cover**
SH00000064
- Filter**
SH00000213

DRC300

- Side brush assembly set**
191P26-0 (Soft) for tatami mats, etc.
191P28-6 (Standard)
- Main brush complete set**
191P20-2 (Soft) for tatami mats, etc.
191P22-8 (Standard)
- Bottom plate assembly set**
191P24-4
- Magnet tape set**
191P18-9
5m long, with double-sided tape
- Filter H complete set**
191P31-7 **HEPA filter**
- Sponge sheet set**
191X35-7
Sponge part to be attached to Bumper for protection of surrounding objects from damage



Cordless Polisher Scrubber Model: PS001G

Brush 190

Brush bristle type: Soft
Application: For cleaning wooden floors, decks, etc.

1914T0-6



Brush bristle type: Medium
Application: For cleaning general interior floors.

1914T1-4



Brush bristle type: Hard
Application: For cleaning exterior concrete floors and removing grease stains from kitchens and similar areas.

1914T2-2



Brush bristle type: Hard (with abrasive)
Application: For cleaning porcelain tiles and similar surfaces.

1914T3-0



Floor pad

Color*1:	Cleaning ability*2	Cleaning surface	Application
White 1914S5-9	Low	Smooth	For surface polishing of resin wax.
Red 1914S6-7			
Blue 1914S7-5	High	Rough	For cleaning of resin wax.
Brown 1914S8-3			For removing resin wax.
Black 1914S9-1			

*1 The brighter and lighter the color, the finer the grit; the darker and deeper the color, the coarser the grit (industry standard).

*2 Stain and wax removal power

Accessory bag set

An accessory bag made of water-resistant materials for carrying wet accessories. Capable of storing all accessories for this model.

1915D1-8



Pad holder 175 set

Pad holder for Floor pad 200 (used with Floor pad 200)
Attachment portion for the floor pad: hook and loop fastener

1914S4-1

Pad holder 175 set

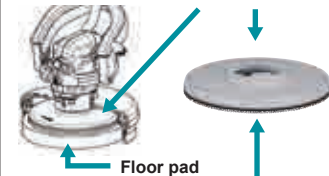

Various pads can be attached to the hook-and-loop side.

Cordless Vacuum Sweeper Model: VS001G

Multi adapter set

- MAKPAC (all types) can be installed, which is also convenient for storing cleaning accessories.
- Portable power pack PDC01 /1200 /1500 can be installed to improve run time.

1913F5-2



Dust bag set

- Capacity: 47L (12.4 gal)
- Dust bag suitable for collecting waste such as fallen leaves.
- Dust bag can be reused.

1913F7-8



Main filter H set

191D12-9

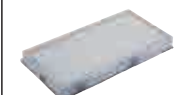







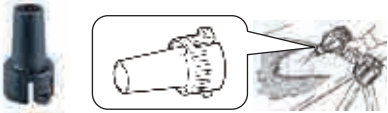

Cleaning

Cordless Dust Blower accessories

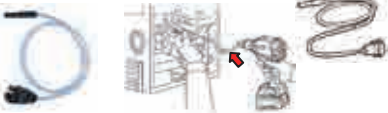
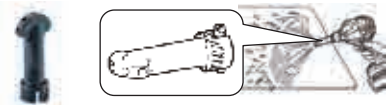
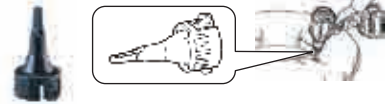
For model:











AS001G, DAS180

*1 Used by attaching to Nozzle 13 and Air vent hose





Item	Description	Part No.
Nozzle 13 set 	Nozzle diameter: ϕ 13mm Nozzle diameter: ϕ 13mm (Same as the caliber of the machine) • For blow-off works • For inflating large play pools, etc.	191X15-3
Nozzle 7 set 	Nozzle diameter: ϕ 7.0mm For filter cleaning	191X13-7
Nozzle 3 set 	Nozzle diameter: ϕ 3.0mm	191X11-1
Flexible nozzle complete set 	Nozzle diameter: ϕ 6.0x800 (Hose) For blowing dust away from OA equipment or narrow spaces where this machine cannot enter	191X21-8
Wide range nozzle set 	Nozzle diameter: ϕ 6.0mm (each hole) For wide range blow-off	191X19-5
Pinch valve nozzle set 	Nozzle diameter: ϕ 7.0mm For inflating/deflating inner tubes and beach balls	191X17-9
Long nozzle set 	Nozzle diameter: ϕ 8.0mm • For cleaning anchor holes • For cleaning narrow spaces that are out of reach Nozzle 13 set (191X15-3) is also necessary.	191X78-9
Air vent hose complete set 	Nozzle diameter: 13mm (Same as the caliber of the machine) For inflating/deflating inner tubes and beach balls (Remove Dust cap complete from the machine and attach this hose.)	191X23-4
Rubber attachment 20 -30 set 	Nozzle diameter: 7.0mm For deflation large play pools and inflatable beds etc.*1 Air vent hose complete set (191X23-4) and nozzle 13 set (191X15-3) are also necessary.	191X25-0
Rubber attachment 65 set 	Nozzle diameter: ϕ 65mm For deflating futon (bedding) compression bag*1 Air vent hose complete set (191X23-4) and nozzle 13 set (191X15-3) are also necessary.	191X27-6
Filter C complete set 	For use of the machine in a dusty environment (Remove Dust cap complete from the machine and attach this Filter.)	191X29-2

Power washer accessories for DHW080, HW1200, HW1300 & HW001G

Shape	Models	Part No.
	DHW080, HW001G HW1200, HW1300	197842-2
	HW001G	1912Y4-1
	HW001G	1912Y5-9
	HW001G	1912Y6-7
	DHW080, HW001G	191M52-1 (TAIWAN)
	DHW080, HW001G HW1200, HW1300	197822-8
	DHW080, HW001G HW1200, HW1300	191U88-8
	DHW080 HW1200, HW1300	191U86-2
	DHW080, HW001G HW1200, HW1300	191U84-6
	DHW080, HW001G HW1200, HW1300	197876-5
	DHW080, HW001G HW1200, HW1300	197824-4
	DHW080, HW001G HW1200, HW1300	197864-2
	DHW080, HW001G *HW1200, *HW1300 (*for 110-127V)	197859-5
	HW1200 **HW1300 (for 220V-240V)	198909-9
	DHW080, HW001G HW1200, HW1300	197870-7
	DHW080, HW001G HW1200, HW1300	197831-7
	DHW080, HW001G HW1200, HW1300	197828-6
	DHW080, HW001G HW1200, HW1300	1912Y2-5











Shape	Models	Part No.	
	DHW080, HW001G HW1200, HW1300	10m	197837-5
		15m	197840-6
	DHW080, HW001G HW1200, HW1300	5m	197845-6
		8m	197847-2
		10m	197850-3
	DHW080, HW001G HW1200, HW1300	197867-6	
	DHW080, HW001G HW1200, HW1300	197873-1	
	DHW080, HW001G HW1200, HW1300	1910R1-6	
	DHW080, HW001G HW1200, HW1300	1910R2-4	
	DHW080, HW001G HW1200, HW1300	197853-7	
	DHW080, HW001G HW1200, HW1300	197883-8	
	DHW080, HW001G HW1200, HW1300	197879-9	
	DHW080	199486-4	
	DHW080	TR00000002 TR00000001 (EU)	

Cordless Pressure Washer for DHW180

Shape	Part No.
	LX00000001
	LX00000004
	LX00000002
	LX00000003
	LX00000063



Outdoor Power Equipment

Blade selection guide



Blade type / Image										
		Short and soft grass			Tall and hard grass			Bush including tree beginning to grow		
Nylon cord		←→								
Plastic blade		←→								
Metal blade		←→								
		←→								
			←→							
Brushcutter blade			←→							
Shredder blade						←→				
Chisel blade								←→		





Metal blade

Still photo	Name	Related models	Blade diameter mm	Number of teeth	Thickness mm	Hole diameter mm	Part No.
	Cutter blade 230-2T	UR016G, UR017G, DUX60	230	2	2	25.4	1916C7-5
	Cutter blade 255-2T	DUR369A, DUR369L, UR006G, UR007G, UR013G, UR101C, UR201C, UX01G	255	2	2.5	25.4	1916D8-0
	Cutter blade 305-2T	UR012G	305	2	2	25.4	1916C8-3
	Brush cutter blade 230x3T	DUR190L, DUR190U, DUR368A, DUR368L, UR002G, UR003G, UR016G, UR017G	230	3	3	25.4	1916C9-1
	Cutter blade 255-3T	DUR369A, DUR369L, UR006G, UR007G, UR012G, UR013G, UR101C, UR201C	255	3	3	25.4	1916D0-6
	Cutter blade 305-3T	UR012G	305	3	3	25.4	1916D1-4
	Brush cutter blade 230x4T	DUR190L, DUR190U, DUR368A, DUR368L, DUR369A, DUR369L, UR002G, UR003G, UR006G, UR007G, UR016G, UR017G, UR101C, UR201C	230	4	1.8	25.4	1916D2-2
	Brush cutter blade 255x4T	DUR369A, DUR369L, UR006G, UR007G, UR012G, UR013G, UR101C, UR201C	255	4	2	25.4	1916D3-0

Chisel blade and Protection guard for brushcutter

Chisel blade								Protection guard for brushcutter				
Still photo	Name	Related models	Blade diameter (mm)	Number of teeth	Arbor saiz (mm)	Thickness (mm)	Part No.	Still photo	Name	Related models	Pipe size (mm)	Part No.
	Cutter 225 set MG	DUR369A, UR006G, UR012G, UR013G	225	24	25.4	1.8	199872-9		Protector 225 set MG	UR012G	28	199873-7
										UR013G	25.4	1911Y0-3
										DUR369A, UR006G	25.4	1912L4-0

Shredder blade and Protection guard for brushcutter

Shredder blade							Protection guard for brushcutter				
Still photo	Name	Related models	Blade diameter (mm)	Arbor saiz (mm)	Thickness (mm)	Part No.	Still photo	Name	Related models	Pipe size (mm)	Part No.
	Shredder blade 270 set MG	UR012G, UR013G	270	25.4	3.9	199874-5		Protector set MG	UR012G	28	199875-3
									UR013G	25.4	1911Y1-1

Edger blade

Still photo	Name	Related models	Cutting width (mm)	Part No.
	Blade set	EE400MP, UE001G	2.5	1916D6-4

Grass trimmer plastic blade

Grass trimmer plastic blade					Replacement plastic blade		
Still photo	Name	Related models	Thread	Part No.	Still photo	per pkg.	Part No.
	Plastic blade 230 set ME	UR100D	M8x1.25RH	198848-3		5	198851-4
	Plastic blade 230 set MG	DUR189, DUR194, DUR368A, DUR368L, UR002G, UR003G	M10x1.25LH	191Y45-0		12	198426-9
	Plastic blade 255 set ME	DUR189, DUR190L, DUR190U, DUR191L, DUR191U, DUR368A, DUR368L, DUR369A, DUR369L, DUR369N, DUX60, UR002G, UR003G, UR006G, UR007G, UR008G, UR016G, UR017G, UR101C, UR201C, UR202C	M8x1.25RH	198383-1			
	Plastic blade 255 set M		M8x1.25LH	198384-9			
	Plastic blade 305 set MG	DUR369A, DUR369L, DUR369N, UR006G, UR007G, UR008G, UR012G, UR013G, UR101C, UR201C, UR202C	M10x1.25LH	199868-0		12	199870-3

String trimmer head

Quick loading Trimmer Head

(UN-74L, UN-72L, 96-M8L/R, 96-M10L, 121-M10L)

Nylon cord can be feded without opening the head

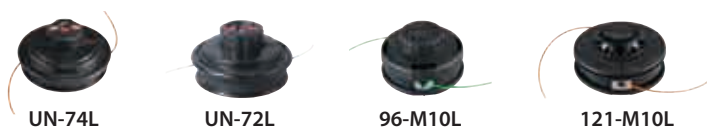

0 85(sec.)

General trimmer head		1. Disassemble trimmer head
		2. Wind nylon cord on spool
		3. Fix spool on trimmer head
		4. Assemble trimmer head
		5. Finish

0 35(sec.)

Quick loading trimmer head (e.g. 96-M10L)		1. Align triangles
		2. Feed the line
		3. Twist the knob
		4. Finish

Up to 58% less feeding time!





String trimmer head

Still photo	Name	Related models	Reference	Thread	Nylon cord diameter mm	Nylon cord length m	Cross-sectional shape	Size inch	Part No.
	Spool Set	DUR181, UR140D, UR180D	-	-	1.65	8	-	-	195858-1
	Nylon cutting head assembly 75-M8R set M	UR100D	76-M8R	M8X1.25RH	1.65	8	FOUR-LEAF	3	198853-0
	Nylon cutting head assembly 75-M8R set ME			M8X1.25RH					198854-8
	Nylon cutting head assembly 95-M8R set M	DUR189	95-M8R	M8X1.25RH	2	3	FOUR-LEAF	4	198972-2
	Nylon cutting head assembly 95-M8R set ME		95-M8R	M8X1.25RH	2	2	FOUR-LEAF	4	198971-4
	Nylon cutting head assembly set		ECO 4R	M8X1.25RH	2	2	FOUR-LEAF	4	197297-1
	Trimmer head 96-M8R set		96-M8R	M8X1.25RH	2	2	-	4	191D92-5



















Still photo	Name	Related models	Reference	Thread	Nylon cord diameter mm	Nylon cord length m	Cross-sectional shape	Size inch	Part No.
	Nylon cutting head assembly 95-M10L set	DUR190L, DUR190U, DUR368A, DUR368L, DUR369A, DUR369L, DUR369N, UR002G, UR003G, UR006G, UR007G, UR008G, UR101C, UR201C, UR202C	95-M10L	M10X1.25LH	2.4	3	FOUR-LEAF	4	197993-1
	Nylon cutting head assembly 95-M10L set		-					4	197994-9
	Nylon cutting head set		UN-74L	M10X1.25LH	2	3.6	FOUR-LEAF	4.4	196324-1
	Cutter assembly 95-M10L set M	DUR190L, UR002G	95-M10L	M10X1.25LH	2	3	FOUR-LEAF	4	198892-0
	Cutter assembly 95-M10L set ME			M10X1.25LH			FOUR-LEAF		198893-8
	Trimmer head 96-M10L set	DUR190L, DUR190U, DUR192L, DUR368A, DUR368L, DUR369A, DUR369L, DUR369N, UR002G, UR003G, UR006G, UR007G, UR008G, UR016G, UR017G, UR101C, UR201C, UR202C	96-M10L	M10X1.25LH	2.0 X 4	4	-	4	191D89-4
	Trimmer head 96-M10L set		96-M10L	M10X1.25LH	2.4 X 3	3	-	4	191D90-9
	Nylon cutting head assembly set	DUR192L, DUR368A, DUR368L, DUR369A, DUR369L, DUR369N, UR002G, UR003G, UR006G, UR007G, UR008G, UR101C, UR201C, UR202C	ECO 4L	M10X1.25LH	2	3	FOUR-LEAF	4	197296-3
	Trimmer head 96-M10L set	DUR190L, DUR192L, DUR368A, DUR368L, DUR369L, DUR369N, UR002G, UR003G, UR006G, UR007G, UR008G, UR201C	96-M10L	M10X1.25LH	2	4	FOUR-LEAF	4	191R00-0
-	Trimmer head assembly 98-M10L	DUR190L, DUR190U, DUR192L, DUR368A, DUR368L, DUR369A, DUR369L, DUR369N, DUX18, DUX60, UR002G, UR003G, UR006G, UR007G, UR008G, UR012G, UR013G, UR016G, UR017G, UR101C, UR201C, UR202C, UX01G	98-M10L	M10X1.25LH	2	3	FOUR-LEAF	4	1915D8-4
-	Trimmer head assembly 98-M10L	DUR190L, DUR190U, DUR192L, DUR368A, DUR368L, DUR369A, DUR369L, DUR369N, DUX60, UR002G, UR003G, UR006G, UR007G, UR008G, UR012G, UR013G, UR016G, UR017G, UR101C, UR201C, UR202C	98-M10L	M10X1.25LH	2.4	3	FOUR-LEAF	4	1915D7-6
	Trimmer head assembly 98-M10L	DUR190L, DUR190U, DUR192L, DUR368A, DUR368L, DUR369A, DUR369L, DUR369N, UR002G, UR003G, UR006G, UR007G, UR008G, UR012G, UR013G, UR016G, UR017G, UR101C, UR201C, UR202C	98-M10L	M8X1.25LH, M10X1.25LH	2.4	3	FOUR-LEAF	4	1914R6-0
-	Trimmer head assembly 98-M10L		98-M10L	M8X1.25LH, M10X1.25LH	2	3	FOUR-LEAF	4	1914R8-6
	Cutter assembly 110-M10L set ME	DUR369A, DUR369L, DUR369N, UR006G, UR007G, UR008G, UR101C, UR201C, UR202C	UN-72L, 110-M10L	M10X1.25LH	2.4	6	FOUR-LEAF	5	198266-5
-	Trimmer head assy 98-M10L S US	DUX60, UX01G	-	-	-	-	-	-	1917R4-2
-	Trimmer head assY 98-M10L S US	DUR192L, DUX18, UR003G, UR008G	98-M10L	-	-	-	-	-	1917R5-0
-	Trimmer head 96-M10L set	UR012G	95-M10L	M10X1.25LH	2.7	2.4	-	4	1912N0-2
	Trimmer head 121-M10L set	UR012G, UR013G	121-M10L	M10X1.25LH	2.4 X 2 (X2)	2 (X2)	-	5	191D93-3
	Trimmer head 105-M10L set mg		Z5L, 105-M10L	M10X1.25LH	2.7	3	FOUR-LEAF	5	199884-2
-	Trimmer head 121-M10L set		121-M10L	M10X1.25LH	2	2 (X2)	-	5	191Y88-2
	Trimmer head 121-M10L set	UR013G	121-M10L	M10X1.25LH	2.7	2 (X2)	-	5	1911Y2-9
	Trimmer head 121-sp set	UR014G	121-M10L	SPLINE 10T	2.7	2 (X2)	-	5	1911Y3-7
-	Spool Ass'y	UR3501	-	-	-	-	-	-	YA00000474
-	String trimmer head assembly	UR3500, UR3501	-	-	-	-	-	-	YA00000649

Outdoor Power Equipment

Line character

Shape	Sharpness	Energy Saving	Quietness	Durability
 Round		A	A	
 Square	AA			
 Four-leaf	A	AA	AA	
 Cored Four-leaf		AA	AA	AA
 Twist-square	AA	AA	AA	

Color chart

Dia.	Color / Shape	Light duty		Heavy duty	
		Low density	High density	Low density	High density
1.3mm		↔			
1.6mm-1.65mm	   	↔			
2.0mm	   		↔		
2.4mm	   		↔	↔	
2.7mm	   			↔	↔
3.0mm	 			↔	↔



Low noise and energy saving

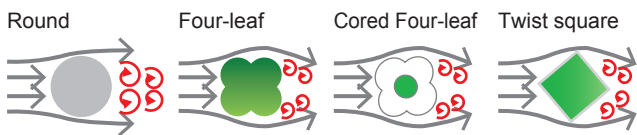

Standard Nylon cord

Color / Shape	Ring	dia. (mm)	length (m)	Part No.
	Single	1.3	15	E-02727
	Single	1.6	15	E-02733
	Single	2.0	15	E-02705
			126	E-02711
			15	E-02749
	Single	2.4	87	E-02761
			262	E-02783
	Single	2.4	15	E-02808
			69	E-02814
			206	E-02820



Twist square Nylon cord

Color / Shape	Ring	dia. (mm)	length (m)	Part No.
	Single	1.65	15	1917V6-6
			30	1917V7-4
			445	1917V8-2
	Single	2.0	15	1917V9-0
			30	1917W0-5
			310	1917W1-3
	Single	2.4	15	1917W2-1
			30	1917W3-9
			225	1917W4-7
	Single	2.7	15	1917W5-5
			30	1917W6-3
			225	1917W7-1

Double-layer Nylon cord

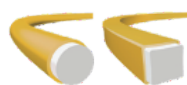
Increased durability up to 130%* thanks to Flexible core coated with Impact & abrasion resistant skin
*compared to standard nylon cord



Color / Shape	Ring	dia. (mm)	length (m)	Part No.
	Single	3.0	15	E-02836
			56	E-02842
			168	E-02858
	Single	3.0	15	E-02870
			44	E-02886
			132	E-02892

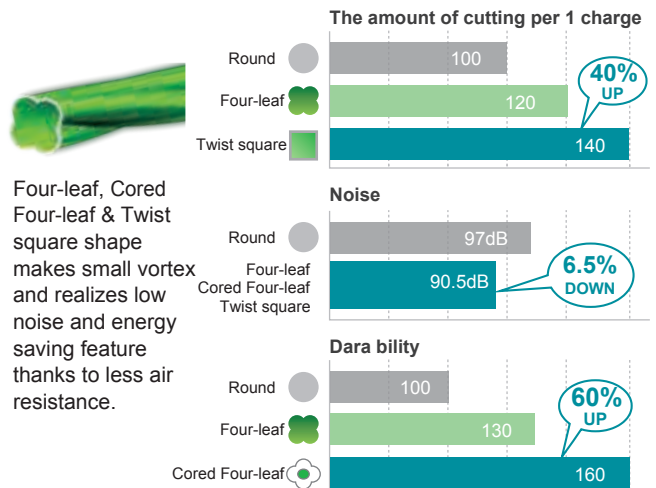

Four-leaf Nylon cord

Color / Shape	Ring	dia. (mm)	length (m)	Part No.
	Single	1.65	15	E-01731
			30	E-01747
			445	E-01753
	Single	2.0	15	E-01769
			30	E-01775
			310	E-01781
	Single	2.4	15	E-01797
			30	E-01806
			225	E-01812
	Single	2.7	15	E-01828
			30	E-01834
			180	E-01840

Cored Four-leaf Nylon cord

Color / Shape	Ring	dia. (mm)	length (m)	Part No.
	Single	1.65	15	1917U4-3
			30	1917U5-1
			445	1917U6-9
	Single	2.0	15	1917U7-7
			30	1917U8-5
			310	1917U9-3
	Single	2.4	15	1917V0-8
			30	1917V1-6
			225	1917V2-4
	Single	2.7	15	1917V3-2
			30	1917V4-0
			180	1917V5-8

Other Nylon cord (round, natural)



Size	Part No.
1.65mmx15m	DA00000003
1.65mmx30m	195861-2
2.4mmx5m	B-01971
3.0mmx4m	B-07375

Attachments for loop handle brushcutter Split shaft attachments

Model	Item	Recommend power unit models
EM401MP	Brushcutter Cutting width: 300mm (String trimmer head): 230mm (Brush cutter blade size) Spindle size: M10 x 1.25LH Arbor size: 25.4mm Gear ratio: 0.74 (14: 19)	DUX60, UX01G
EM402MP	Brushcutter Blade size: 230mm (Brushcutter blades) Spindle size: M10 x 1.25LH Arbor size: 25.4mm Gear ratio: 0.74 (14: 19)	DUX60
EM403MP	Brushcutter Brushcutter Cutting width: 450mm (String trimmer head): 230mm (Brush cutter blade size) Spindle size: M10 x 1.25LH Arbor size: 25.4mm Gear ratio EM403MP: 0.74 (14: 19) High speed type EM404MP: 0.62 (13: 21) High torque & Low noise type	DUX60, UX01G
EM404MP		DUX60 with CE mark, UX01G with CE mark
EM405MP	Brushcutter (Narrow guard for String trimmer head) Cutting width: 450mm Spindle size: M10 x 1.25LH Gear ratio EM405MP: 0.74 (14: 19) High speed type EM406MP: 0.62 (13: 21) High torque & Low noise type	DUX60, UX01G
EM406MP		DUX60 with CE mark, UX01G with CE mark,
EM407MP	Rotary scissors attach Set Cutting width: 230mm Stone & grass antiscattering brushcutter attachment.	DUX18, DUX60, UX01G
	Replacement blade P/N: SY00146013 Replacement blade P/N: SY00146014	
EM408MP	Brushcutter Cutting width: 300mm (String trimmer head): 230mm (Brush cutter blade size) Spindle size: M10 x 1.25LH Arbor size: 25.4mm Gear ratio: 0.74 (14: 19)	DUX18, DUX60, UX01G
EM409MP	Brushcutter (Narrowguard for String trimmer head) Cutting width: 300mm Spindle size: M10 x 1.25LH Gear ratio: 0.74 (14: 19)	DUX18, DUX60, UX01G
EE400MP	Edger attachment Blade size: Diameter: 203mm Hole diameter: 25.4mm Replacement blade P/N: 196745-7	DUX18, DUX60, UX01G
UB400MP	Blower Max. Air volume: 16.6 m ³ /min (UX01G) Except for European, Austrarian, markets .Newzealand, Chinese & Korean	DUX18, DUX60, UX01G
UB401MP	Blower Max. Air volume: 16.4 m ³ /min (UX01G)	DUX18, DUX60, UX01G
UB402MP	Blower Max. Air volume: 6.2 m ³ /min (UX01G)	DUX18, DUX60, UX01G
PF400MP	Pump Attachment Hose size (Inner diameter): 25mm / 1" DUX18/ DUX60/ UX01G Max. lift height (m): 11/ 14/ 15 Max. flow rate (l/min): 120/ 145/ 150	DUX18, DUX60, UX01G

Model	Item	Recommend power unit models
EY402MP	Pole saw Guide bar length: 25cm (10") Saw chain: 90PX-40links	DUX18, DUX60, UX01G
EY403MP	Pole saw Guide bar length: 30cm (12") Saw chain: 90PX-46links or 91PX-46links Motor Mount: A041	DUX18, DUX60, UX01G
EN401MP	Pole hedge trimmer, Angle adjustment, Effective cutting length: 490mm Shear blade 500set P/N: 198049-3 with End cover set: P/N: 197763-8 (MG), 197768-8 (ME)	DUX18, DUX60, UX01G
EN402MP	Pole hedge trimmer Effective cutting length: 500mm Shear blade 500set P/N: 1912G3-7	DUX18, DUX60, UX01G
EN410MP	Pole hedge trimmer Straight Effective cutting length: 490mm Shear blade 500set P/N: 198049-3 with End cover set: P/N: 197763-8 (MG), 197768-8 (ME)	DUX18, DUX60, UX01G
EN420MP	Ground trimmer Effective cutting length: 250mm Shear blade 250set P/N: 198195-2	DUX18, DUX60, UX01G
EN422MP	Ground trimmer Effective cutting length: 250mm Shear blade 250 set P/N: 122D74-6	DUX18, DUX60, UX01G
EN424MP	Ground trimmer Effective cutting length: 330mm Shear blade 330 set P/N: 1912V6-6	DUX18, DUX60, UX01G
EN425MP	Ground trimmer Effective cutting length: 500mm Shear blade 500 set P/N: 1916X3-0	DUX18, DUX60, UX01G
KR400MP	Cultivator Cultivating width: 160mm	DUX18, DUX60, UX01G
KR401MP	Cultivator Cultivating width: 220mm Rotor LR set: P/N: 199204-0	DUX18, DUX60, UX01G
WA400MP	Weeding Effective cutting length: 220mm Weeding blade 220 set P/N: 1913L5-4 Cultivator blade 170 set P/N: 1913L7-0 Weeding blade 80 set P/N: 1913L6-2	DUX18, DUX60, UX01G
BR400MP	Power brush Working width: 600mm Brush wheel (1pc) P/N: XNR0000548	DUX18, DUX60, UX01G
SW400MP	Power sweep Working width: 590mm Sweeper wheel (1pc) P/N: XNR0000549	DUX18, DUX60, UX01G
EJ400MP	Coffee harvester	DUX18, DUX60, UX01G
SN400MP	Snow Blower Attachment Max snow throwing distance: 12m Snow clearing width: 300mm	DUX18, DUX60, UX01G
LE400MP	Shaft extension attachment (1.08m (42-1/2")) For Pole saw, Pole hedge trimmer and Coffee harvester	DUX18, DUX60, UX01G

Outdoor Power Equipment

Protection guard for brushcutter

Still photo	Name	Related models	Type	Part No.
	Protector N 430 set MG	DUR369A, DUR369L, DUR369N, UR006G, UR007G, UR008G, UR101C, UR201C, UR202C	Exclusive	191B55-9
	Protector set	DUX60	-	196353-4
	Protector U 330 set	UR002G, UR003G	-	197294-7
	Protector U 430 set MG	UR016G, UR017G	-	197295-5
	Protector U 430 set MG	DUR369A, DUR369L, UR006G, UR007G, UR101C, UR201C	-	1911X4-8
	Protector U 430 set MG	DUR369A, DUR369L, UR006G, UR007G, UR101C, UR201C	-	191B54-1

Harness

Still photo	Name	Related models	Type	Part No.
		DUA250, DUA251, DUA300, DUA301, UA001G, UA002G, UA003G, UA004G, UR101C, UR201C, UX01G	String trimmer harness for pdc	197243-4
	Band assembly set	DUA250, DUA251, DUA300, DUA301, UA001G, UA002G, UA003G, UA004G	Comfort	191K37-5
	Band assembly set	DUR369A, UR006G, UR007G, UR012G, UR013G	Comfort	199378-7
	Band assembly set	DUR369A, UR012G	Comfort	196129-9
	Band assembly set BL	UR012G, UR013G	Comfort	1915M3-7
	Band assembly set OR	UR012G, UR013G	Comfort	1915M4-5

Pruning shear blade

Still photo	Name	Related models	Type	Part No.
	Shear blade L set	DUP180	L	1913P3-6
		DUP361, DUP362		197367-6
		UP100D		197749-2
		DUP180		199169-6
		DUP180		1911W1-7
	Shear blade U set	DUP180	U	1913P4-4
		DUP361, DUP362		197366-8
		UP100D		197588-0
		UP100D		197748-4
		UP100D		199168-8
		UP100D		1911W2-5

Long handle attachment for pruning shear

Still photo	Name	Related models	Part No.
	Long handle attachment set	DUP180, UP100D	1916B3-6

Dressing stone for shears

Still photo	Name	Related models	Part No.
	Dressing stone set	DUP180, UP100D	1912E4-1

Sprayer accessory

Still photo	Name	Related models	Part No.
-	Deflector set DE		198250-0
-	Deflector set ME		198249-5
	Deflector set MG	PM001G	198248-7
-	Harness LR set		PR00000319
-	Single nozzle assy	DUS108, DUS158	PR00000251
-	Twin head mist nozzle assy	DUS108, DUS158	PR00000255
	Weeding nozzle with cover	DUS054, DUS108, DUS158, US053D	AB45127080

Pouch and holder

Still photo	Name	Related models	Part No.
-	Battery bag set	DUB362, DUC353, DUC355, DUX60	199297-7
	Holster	TD022D	168435-2
	Holster set	DUC101, DUC150, UC029G	1913K4-9
	Holster set	DUC101, UC100D	1911R0-4

Pole saw angle attachment

Still photo	Name	Related models	Part No.
	Angle attachment set	DUA250, DUA251, DUA300, DUA301, UA001G, UA002G, UA003G, UA004G	1910J6-0

Saw Chain and Guide Bar



A Guide Bar Length
Guide bar's length is represented by cutting length, which is different from its whole length.



B Drive Link
The length of saw chain is determined by counting the number of drive links in the saw chain.

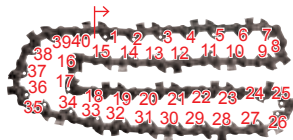

C Chain Pitch
Chain pitch is the size of the chain and it is defined by the distance between any three consecutive rivets divided by two. Pitch is important because the drive sprocket must be the same pitch as the chain.



D Gauge
Chain Gauge is thickness of drive link which will fit into the guide bar groove. Chain gauge must be the same as guide bar gauge.

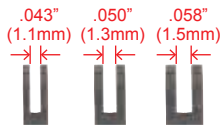

E Depth Gauge
Depth gauge determines how deep the cutting teeth gets into the wood. Cutting depth can be checked by the gap between top of cutter and depth gauge.



General Saw Chain Character

D Gauge	Chain Pitch			
	.043" (1.1mm)	.050" (1.3mm)	.058" (1.5mm)	.063" (1.6mm)
3/16"	M01			
1/4"		25AP		
.325"LP	80TXL			
3/8"LP	M41 90PX	M43 91PX 91VXL		
.325" narrow kerf		95VPX 95TXL		
.325"		20BPX	21BPX 21LPX	22BPX 22LPX
3/8"		72V	73DPX 73LGX 73LPX	
.404"				27X

Guide Bar Type

Sprocket Nose Bars

Sprocket nose bars have a rotating sprocket mounted at the tip of the bar. As the chain moves along the bar, the sprocket teeth carry the chain around the tip smoothly with less friction.



High durability sprocket nose bar

Longer nose life thanks to larger nose sprocket than normal sprocket bars. Multiple rivets can be found on bar surface.



Solid Carving Bars

Carving bars are made of high-quality steel and high wear resistant stellite has been welded onto the tip. Bar tip is designed to have small radius for precision cutting. The carving bars are made for especially pruning and carving.



Guide Bar Maintenance

Chain Tension

Check the chain tension before use. The saw chain may become loose after many hours of use.



File Bar Edge

File bar edge with a flat file to keep it 90° once a week.



Clean Guide Bar

Clean out chips and sawdust every time when you sharpen or replace saw chain.



Bar Nose Grease

Lubricate a whole sprocket regularly so that the saw chain can rotate with less friction.



Outdoor Power Equipment

Chain Saws

Guide Bar / Saw Chain / Guide Bar Cover / Drive sprocket

Cutter type: CC: Chamfer chisel, SC: Semi chisel, MC : Micro chisel, FC: Full chisel



Model No.	Guide Bar				Saw Chain						Bar Cover	Drive sprocket		
	Bar length	Motor Mount	Type	Part No.	No. of drive links	Gauge	Pitch	Type OREGON	Cutter type	Part No. (Carton)	Part No.	Type	Part No.	
Pole Saws														
DUA200	20cm/8"	A041	Sprocket nose bar	1914S3-3	38	1.1mm/.043"	.325"LP	80TXL	MC	1914S1-7	413G28-5	.325"LP 7T		
EY402MP	25cm/10"	A041	Sprocket nose bar	191G14-3	40	1.1mm/.043"	3/8"LP	90PX	CC	191H00-0	452093-7 / 458501-6	3/8"LP 6T	226992-7	
EY403MP	30cm/12"	A041		191G15-1	46					191H01-8				419288-5 / 413G23-5
DUA250, DUA251	25cm/10"	A041	Sprocket nose bar	191G22-4	40	1.3mm/.050"	3/8"LP	91PX	CC	191H08-4	452093-7 / 458501-6	3/8"LP 6T	226992-7	
DUA300, DUA301 UA001G, UA002G UA003G, UA004G	30cm/12"	A041		191G23-2	46					191H10-7				419288-5 / 413G23-5
Cordless Pruning Saw														
DUC101, UC100D	10cm/4"	F002	without sprocket	1910W0-3	26	1.1mm/.043"	.325"LP	80TXL	MC	1910V6-4	413M40-1	.325"LP 7T	1911W5-9	
DUC150, UC029G	15cm/6"	F002		1912F1-4	32	1.1mm/.043"	.325"LP	80TXL	MC	1912E8-3	413T67-3	.325"LP 7T	1911W5-9	
Cordless Chain Saws														
DUC122	11.5cm/4-1/2"	-	without sprocket	158476-6	42	1.3mm/.050"	1/4"	25AP	MC	191G95-7	416311-7	1/4" 9T	221527-9	
UC021G, UC022G UC023G, UC024G UC025G, UC026G	30cm/12"	A041	Sprocket nose bar	191T86-6	51	1.1mm/.043"	.325"LP	80TXL	MC	191T90-5	419288-5 / 413G23-5	Sprocket .325" LP 7 tooth	191V91-5	
	35cm/14"	A041		191T87-4	59					191T91-3				419288-5 / 413G23-5
	40cm/16"	A041		191T88-2	64					191T92-1				419242-9 / 413G21-9
DUC256 DUC306 DUC356 DUC406 DUC256C	25cm/10"	-	Solid carving bar	1911A1-3	60	1.3mm/.050"	1/4"	25AP	MC	191G96-5	452093-7 / 458501-6	Sprocket 1/4" 9 tooth	198259-2	
	25cm/10"	A041	Sprocket nose bar	191T85-8	46	1.1mm/.043"	.325"LP	80TXL	MC	191T89-0	452093-7 / 458501-6	Sprocket .325" LP 7 tooth	1911W5-9	
	30cm/12"	A041		191T86-6	51					191T90-5				419288-5 / 413G23-5
	35cm/14"	A041		191T87-4	59					191T91-3				419288-5 / 413G23-5
	40cm/16"	A041		191T88-2	64					191T92-1				419242-9 / 413G21-9
	25cm/10"	A041	Sprocket nose bar	191G14-3	40	1.1mm/.043"	3/8"LP	90PX	CC	191H00-0	452093-7 / 458501-6	Sprocket 3/8" LP 6 tooth	199063-2	
	30cm/12"	A041		191G15-1	46					191H01-8				419288-5 / 413G23-5
	35cm/14"	A041		191G16-9	52					191H02-6				419288-5 / 413G23-5
	40cm/16"	A041		191G17-7	56					191H03-4				419242-9 / 413G21-9
	25cm/10"	A041	Sprocket nose bar	191G22-4	40	1.3mm/.050"	3/8"LP	91PX	CC	191H08-4	452093-7 / 458501-6	Sprocket 3/8" LP 6 tooth	199063-2	
	30cm/12"	A041		191G23-2	46					191H10-7				419288-5 / 413G23-5
	35cm/14"	A041		191G24-0	52					191H11-5				419288-5 / 413G23-5
	40cm/16"	A041		191G25-8	56					191H12-3				419242-9 / 413G21-9
	DUC258	25cm/10"	A041	Sprocket nose bar	191T85-8	46	1.1mm/.043"	.325"LP	80TXL	MC	191T89-0	413G28-5 / 458501-6	Sprocket .325" LP 7 tooth	1916N6-4
20cm/8"		A041	Sprocket nose bar	191G13-5	33	1.1mm/.043"	3/8"LP	90PX	CC	191G99-9	413G28-5 / 458501-6	Sprocket 3/8" LP 6 tooth	1916N7-2	
25cm/10"		A041	Sprocket nose bar	191G14-3	40	191H00-0								
DUC307 DUC357 DUC407	30cm/12"	A041	Sprocket nose bar	191G15-1	46	1.1mm/.043"	3/8"LP	90PX	CC	191H01-8	419288-5 / 413G23-5	Sprocket 3/8" LP 6 tooth	199063-2	
	35cm/14"	A041		191G16-9	52					191H02-6				419288-5 / 413G23-5
	40cm/16"	A041		191G17-7	56					191H03-4				419242-9 / 413G21-9
	30cm/12"	A041	Sprocket nose bar	191G23-2	46	1.3mm/.050"	3/8"LP	91PX	CC	191H10-7	419288-5 / 413G23-5	Sprocket 3/8" LP 6 tooth	199063-2	
	35cm/14"	A041		191G24-0	52					191H11-5				419288-5 / 413G23-5
	40cm/16"	A041		191G25-8	56					191H12-3				419242-9 / 413G21-9
DUC303 DUC353 DUC400 DUC305 DUC355 DUC405	25cm/10"	-	Solid carving bar	1911A1-3	60	1.3mm/.050"	1/4"	25AP	MC	191G96-5	452093-7 / 458501-6	Sprocket 1/4" 9 tooth	198259-2	
	30cm/12"	A041	Sprocket nose bar	191G15-1	46	1.1mm/.043"	3/8"LP	90PX	CC	191H01-8	419288-5 / 413G23-5	Sprocket 3/8" LP 6 tooth	199063-2	
	35cm/14"	A041		191G16-9	52					191H02-6				419288-5 / 413G23-5
	40cm/16"	A041		191G17-7	56					191H03-4				419242-9 / 413G21-9
	30cm/12"	A041		191G23-2	46					191H10-7				419288-5 / 413G23-5
	35cm/14"	A041	Sprocket nose bar	191G24-0	52	1.3mm/.050"	3/8"LP	91PX	CC	191H11-5	419288-5 / 413G23-5	Sprocket 3/8" LP 6 tooth	199063-2	
	40cm/16"	A041		191G25-8	56					191H12-3				419242-9 / 413G21-9
40cm/16"	A041													
UC030G	40cm/16"	D025	Sprocket nose bar	1915Y7-3	67	1.3mm/.050"	.325"	95TXL	MC	1916A1-3	4133L9-9	Sprocket .325" 7 tooth	1916A5-5	
	45cm/18"	D025		1915Y8-1	74					1916A2-1				
	50cm/20"	D025		1915Y9-9	82					1916A3-9				
	50cm/20"	D025	Sprocket nose bar	1916A0-5	82	1.6mm/.063"	.325"	22BPX	MC	1916A4-7	4133H6-7			
UC031G	25cm/10"	A041	Sprocket nose bar	191T85-8	46	1.1mm/.043"	.325"	80TXL	MC	191T89-0	413X66-9	Sprocket .325" 7 tooth	1916N6-4	
	30cm/12"	A041	Sprocket nose bar	191G15-1	46	1.1mm/.043"	3/8"	90PX	CC	191H01-8	413G23-5	Sprocket 3/8" LP 6 tooth	1916N7-2	

Model No.	Guide Bar					Saw Chain					Bar Cover	Drive sprocket	
	Bar length	Motor Mount	Type	Part No.	No. of drive links	Gauge	Pitch	Type OREGON	Cutter type	Part No. (Carton)	Part No.	Type	Part No.
UC002G UC003G UC004G UC005G UC006G UC007G	25cm/10"	-	Solid carving bar	1911A1-3	60	1.3mm/.050"	1/4"	25AP	MC	191G96-5	452093-7 / 458501-6	Sprocket 1/4" 9T	191V92-3
	25cm/10"	A041	Sprocket nose bar	191T85-8	46	1.1mm/.043"	.325" LP	80TXL	MC	191T89-0	452093-7 / 458501-6	Sprocket 3/8" LP 7 tooth	191V91-5
	30cm/12"	A041		191T86-6	51					191T90-5	419288-5 / 413G23-5		
	35cm/14"	A041		191T87-4	59					191T91-3	419288-5 / 413G23-5		
	25cm/10"	A041	Sprocket nose bar	191G14-3	40	1.1mm/.043"	3/8" LP	90PX	CC	191H00-0	452093-7 / 458501-6	Sprocket 3/8" LP 6 tooth	191V90-7
	30cm/12"	A041		191G15-1	46					191H01-8	419288-5 / 413G23-5		
	35cm/14"	A041		191G16-9	52					191H02-6	419288-5 / 413G23-5		
	25cm/10"	A041		191G22-4	40					191H08-4	452093-7 / 458501-6		
	30cm/12"	A041	Sprocket nose bar	191G23-2	46	1.3mm/.050"	3/8" LP	91PX	CC	191H10-7	419288-5 / 413G23-5	Sprocket 3/8" LP 7 tooth	191V91-5
	35cm/14"	A041		191G24-0	52					191H11-5	419288-5 / 413G23-5		
UC010G UC011G UC012G UC013G UC014G UC015G UC016G UC017G UC020G	30cm/12"	A041	Sprocket nose bar	191T86-6	51	1.1mm/.043"	.325" LP	80TXL	MC	191T90-5	419288-5 / 413G23-5	Sprocket 3/8" LP 7 tooth	191V91-5
	35cm/14"	A041		191T87-4	59					191T91-3	419288-5 / 413G23-5		
	40cm/16"	A041		191T88-2	64					191T92-1	419242-9 / 413G21-9		
	45cm/18"	A041	Sprocket nose bar	191X03-0	70	1.1mm/.043"	3/8" LP	90PX	CC	191X04-8	419242-9 / 413G21-9	Sprocket 3/8" LP 6 tooth	191V90-7
	30cm/12"	A041		191G15-1	46					191H01-8	419288-5 / 413G23-5		
	35cm/14"	A041		191G16-9	52					191H02-6	419288-5 / 413G23-5		
	40cm/16"	A041		191G17-7	56					191H03-4	419242-9 / 413G21-9		
	30cm/12"	A041	Sprocket nose bar	191G23-2	46	1.3mm/.050"	3/8" LP	91PX	CC	191H10-7	419288-5 / 413G23-5	Sprocket 3/8" LP 6 tooth	191V90-7
	35cm/14"	A041		191G24-0	52					191H11-5	419288-5 / 413G23-5		
	40cm/16"	A041	Sprocket nose bar	191G25-8	56	1.3mm/.050"	3/8" LP	91PX	CC	191H12-3	419242-9 / 413G21-9	Sprocket 3/8" LP 6 tooth	191V90-7
45cm/18"	A041	191G26-6		62	191H13-1					419242-9 / 413G21-9			

Electric Chain Saws

UC3041A UC3541A UC4041A	30cm/12"	A041	Sprocket nose bar	191G15-1	46	1.1mm/.043"	3/8" LP	90PX	CC	191H01-8	419288-5 / 413G23-5	Sprocket 3/8" LP 6 tooth	221526-1
	35cm/14"	A041		191G16-9	52					191H02-6	419288-5 / 413G23-5		
	40cm/16"	A041		191G17-7	56					191H03-4	419242-9 / 413G21-9		
	30cm/12"	A041	Sprocket nose bar	191G23-2	46	1.3mm/.050"	3/8" LP	91PX	CC	191H10-7	419288-5 / 413G23-5	Sprocket 3/8" LP 6 tooth	221521-1
	35cm/14"	A041		191G24-0	52					191H11-5	419288-5 / 413G23-5		
40cm/16"	A041	191G25-8	56	191H12-3	419242-9 / 413G21-9								
UC3050A, UC3550A, UC4050A, UC4550A, UC3051A, UC3551A, UC4051A, UC4551A	30cm/12"	A041	Sprocket nose bar	191G23-2	46	1.3mm/.050"	3/8" LP	91PX	CC	191H10-7	419288-5 / 413G23-5	Sprocket 3/8" LP 6 tooth	221521-1
	35cm/14"	A041		191G24-0	52					191H11-5	419288-5 / 413G23-5		
	40cm/16"	A041		191G33-9	56					191H12-3	419242-9 / 413G21-9		
	40cm/16"	A041		191G25-8	56					191H13-1	419242-9 / 413G21-9		
	45cm/18"	A041		191G34-7	62					191H13-1	419242-9 / 413G21-9		

NEW Saw chain M01



Model No.	Guide Bar		Saw Chain				Drive sprocket		
	Bar length	Part No.	Gauge	Pitch	Type Makita	No. of drive links	Part No. (Carton)	Type	Part No.
DUC101, UC100D	10cm/4"	1910W0-3	1.1mm/.043"	3/16"	M01	44	1918H6-4	Sprocket 3/16"	227C69-9
DUC150, UC029G	15cm/6"	1912F1-4				54	1918H7-2		

Saw chain M41 (Similar to 90PX), M43 (Similar to 91PX)

Low profile chain blades. Compared to regular 3/8" saw chains, due to its low cutting resistance, it is suitable for use with small-displacement gas-powered chain saws and cordless chain saws.









Cutter type: SC

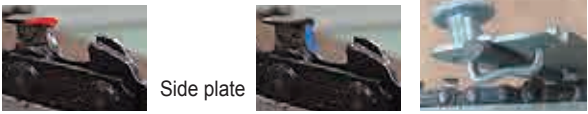

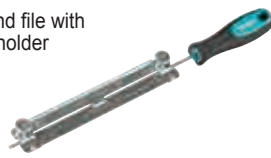
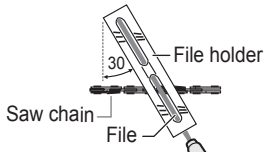

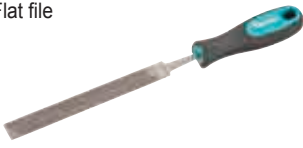
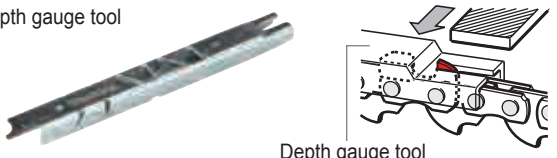

Guide Bar		Saw Chain				Similar Saw Chain				
Bar length	Gauge	Pitch	Type Makita	No. of drive links	Part No. (Carton)	Gauge	Pitch	Type OREGON	No. of drive links	Part No. (Carton)
25cm/10"	1.1mm/.043"	3/8" (Similar to LP)	M41	40	1914F1-6	1.1mm/.043"	3/8" LP	90PX	40	191H00-0
30cm/12"				46	1914F2-4				46	191H01-8
35cm/14"				52	1914F3-2				52	191H02-6
40cm/16"				56	1914F4-0				56	191H03-4
25cm/10"	1.3mm/.050"	3/8" (Similar to LP)	M43	40	1914F5-8	1.3mm/.050"	3/8" LP	91PX	40	191H08-4
30cm/12"				46	1914F6-6				46	191H10-7
35cm/14"				52	1914F7-4				52	191H11-5
40cm/16"				56	1914F8-2				56	191H12-3

Sharpening Saw Chain

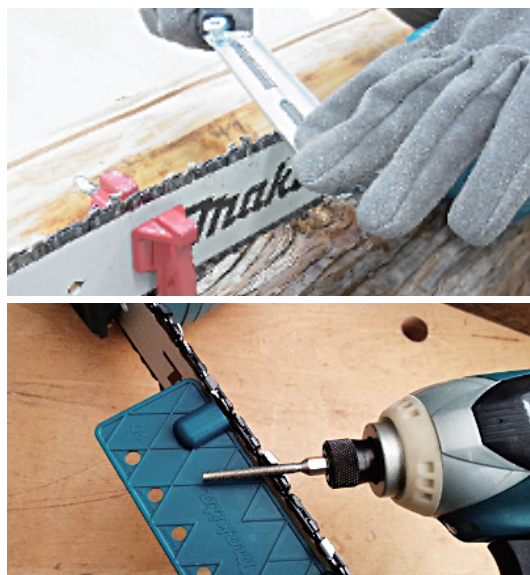
<How to Sharpening Saw Chain>	<Using accessory>
<h3>1. To sharpen Cutting Corner & Side Plate</h3>	
<p>To sharpen Cutting corner & Side plate, use Round file.</p>  <p>Cutting corner Side plate</p>	<p>Round file Round file bit (for power tool)</p> 
<p>When use a file, try to keep 1/5 of the Round file diameter appeared from the saw chain.</p> <p>With a File holder, it is easy to keep 1/5 file diameter appeared.</p> 	<p>Round file with File holder</p> 
<p>There are appropriate angles to use a file, according to a Saw Chain type. File holder or Angle plate are used to see the appropriate angle.</p> 	<p>Round file with File holder Angle Plate</p> 
<p>If you have to sharpen Saw Chain outdoors where it is difficult to secure your Chain Saw, drive the Filing vise into the wood and you can use a file anywhere.</p>	<p>Filing vise</p> 
<h3>2. To grind Depth gauge</h3>	
<p>Use a Flat file to adjust Depth Gauge height.</p> 	<p>Flat file</p> 
<p>Depth gauge tool is to see adjustment necessity and how much to grind off Depth Gauge. Put on Depth gauge tool on Depth Gauge and grind off Depth Gauge's exposed part with a Flat file.</p>	<p>Depth gauge tool</p> 

Diameter and sharpening angle of Round file

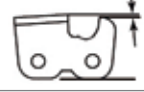

				
M01	2.8mm / 7/64"	35°	0.50mm / .020"	
25AP	4.0mm / 5/32"	30°	0.65mm / .025"	
80TXL	4.0mm / 5/32"	30°	0.65mm / .025"	
90PX	4.5mm / 11/64"	30°	0.65mm / .025"	
91PX / M43 / M41	4.0mm / 5/32"	30°	0.65mm / .025"	
91VXL				
95VPX / 95TXL	4.8mm / 3/16"	30°	0.65mm / .025"	
20BPX	4.8mm / 3/16"	30°	0.65mm / .025"	
21BPX / 22BPX				
21LPX	4.8mm / 3/16"	25°	0.65mm / .025"	
72V	5.5mm / 7/32"	25°	0.65mm / .025"	
73DPX	5.5mm / 7/32"	30°	0.65mm / .025"	
73LPX	5.5mm / 7/32"	25°	0.65mm / .025"	
27X	5.5mm / 7/32"	30°	0.75mm / .030"	

File and File holder

For Model: Chain saw



Saw chain type	File			File and File holder
	Size	Q'ty	Part No.	Part No.
25F, 25AP, 80TXL, 91P, 91PX, 91PXL, 91VXL, M41, M43	4mm 5/32"	2	D-67359	D-70948
		12	D-67365	
90PX, 90SG	4.5mm 11/64"	2	D-67371	D-70954
		12	D-67387	
95VPX/ TXL, 20BPX/ LPX/, 21BPX/ LPX, 22BPX/ LPX, 082, 086, 686, 484	4.8mm 3/16"	2	D-67393	197712-5 D-70960
		12	D-67402	
72DPX/ LPX, 73DPX/ LPX, 75DPX/ LPX	5.2mm 13/64"	2	D-67418	D-70976
		12	D-67424	
72DPX/ LPX/ APX/ EXL/ EXJ/ LGX/ JGX/ JPY/ RDV, 73DPX/ LPX/ EXL/ EXJ/ LGX/ JGX/ JPY/ RDV, 75DPX/ LPX / EXL/ EXJ/ LGX/ JGX/ JPY/ RDV, 496, 093, 099	5.5mm 7/32"	2	D-67430	D-70982
		12	D-67446	

Round file bit

For all saw chain



Description	Size	Part No.
Round File bit 6.35mm (1/4) Hex shank (MZ)	Ø4.0mm (5/32")	D-73748
	Ø4.5mm (11/64")	D-73754
	Ø4.8mm (3/16")	D-73760
	Ø5.2mm (13/64")	D-73776
	Ø5.5mm (7/32")	D-73782

Cone sharpening bit

For all saw chain



Description	Diamond File Size	Part No.
Cone sharpening bit	Ø2.8mm (7/64") - Ø5.5mm (7/32")	D-82937

Angle plate / Angle plate & Diamond file bit set

For all saw chain



Description	Diamond File Size	Part No.
Angle Plate (25 / 30deg.)	-	D-75605
Angle Plate & Diamond File bit 1/4" Hex shank (MZ) set	Ø4.0mm (5/32")	D-75611
	Ø4.5mm (11/64")	D-75627
	Ø4.8mm (3/16")	D-75633
	Ø5.2mm (13/64")	D-75649
	Ø5.5mm (7/32")	D-75655

Flat file, Depth gauge

For all saw chain

Depth gauge : .025 / 0.64mm



Flat file		Depth gauge	Flat file and File handle and Depth gauge
Q'ty	Part No.	Part No.	Part No.
1	D-67452	D-67474	D-70998
12	D-67468		

File set for in roll up pouch

For all saw chain



Description	Part No.
Ø4.0mm Round File(3pcs) / File Holder / Flat File / Handle(2pcs) / Depth Gauge	D-72154
Ø4.5mm Round File(3pcs) / File Holder / Flat File / Handle(2pcs) / Depth Gauge	D-72160
Ø4.8mm Round File(3pcs) / File Holder / Flat File / Handle(2pcs) / Depth Gauge	D-72176
Ø5.2mm Round File(3pcs) / File Holder / Flat File / Handle(2pcs) / Depth Gauge	D-72182
Ø5.5mm Round File(3pcs) / File Holder / Flat File / Handle(2pcs) / Depth Gauge	D-72198

File handle



Q'ty	Part No.
1	D-67496
50	D-67505

Filing vise



Part No.
D-67480

Chain oil



Size	Part No.
250ml	1910U6-7
100ml	199897-3
1L	195093-1
1L	196946-7
1L	195092-3
5L	1910T9-4
60L	1910U8-3

Spike bumper



Related models	Part No.
DUC122	197944-4
DUC258, UC031G	1917P5-6

Outdoor Power Equipment

Compatible hedge trimmer blade



Name	Related models	Cutting width mm	Part No.
Shear blade assembly 200S set	DUM111, DUM604, UH200D, UH201D, UM164D, UM600D	200	191N24-2
			198408-1
			198409-9
			195178-3
Shear blade assembly set		-	195243-8
			195272-1

End cover, blade cover for hedge trimmer

Still photo	Name	Related models	Part No.
	Blade cover set	DUM111, DUM604, UH200D, UH201D, UM164D, UM600D	195274-7

Compatible grass shear blade



Name	Related models	Cutting width mm	Part No.
Shear blade assembly 110 set	DUM111, DUM604, UH200D, UH201D, UM164D, UM600D	110	191N23-4
Shear blade assembly set		-	195176-7
		160	195267-4

Grass receiver

Still photo	Name	Related models	Working width mm	Part No.
	Grass receiver 110 set	DUM111	110	191N25-0
	Grass receiver 160 set	DUM111, UH201D	160	198412-0

Base frame

Still photo	Name	Related models	Part No.
	Base frame set	UH200D, UM164D	195269-0
			195270-5

Long attachment handle for grass shear

Still photo	Name	Related models	Part No.
	Long handle attachment set	DUM604	198516-8
		UM164D	195187-2

Hedge trimmer blade



Name	Related models	Cutting width mm	Part No.
Shear blade 500E set	DUH507, DUH607	500	1911J1-6
Shear blade 600E set		600	1911J2-4
		500	1910H8-2
Shear blade 500E set	DUH506, DUH606, UH020G, UH021G	500	1914G4-7
Shear blade 600E set		600	1910H9-0
		600	1914G5-5
Shear blade assembly 500A set	DUH502, DUH601, DUH602, DUH751, DUH752	500	199236-7
Shear blade assembly 600A set		600	199101-0
Shear blade assembly 750A set		750	199102-8
Shear blade assembly 500 set	DUH501, DUH502, DUH601, DUH602, DUH751, DUH752	500	199098-3
Shear blade assembly 500S set			199598-3
Shear blade 500 set	DUH501, DUH502, DUH601, DUH602, DUH751, DUH752, UH004G, UH005G, UH008G, UH009G	600	191T44-2
Shear blade 500S set			191T47-6
Shear blade 600 S set			191R57-1
Shear blade 600 set	DUH501, DUH502, DUH601, DUH602, DUH751, DUH752, UH004G, UH005G, UH008G, UH009G	750	191R53-9
Shear blade 750 S set			191R58-9
Shear blade 750 set		-	191R54-7
Shear blade assembly 500 set		-	199100-2
Shear blade assembly 600 set		600	199099-1
Shear blade assembly 600S set		750	199599-1
Shear blade assembly 750S set		750	199600-2
Shear blade assembly set	UH4570, UH5570, UH6570	450	194660-9
		550	194663-3
		-	194665-9
		650	194666-7
		-	194669-1
		-	195254-3
Shear blade assembly set	UH5580, UH6580, UH7580	550	194671-4
		650	194673-0
		750	194675-6

Hedge trimmer rough-cutting blade



Name	Related models	Cutting width mm	Part No.
Shear blade 600 R set	UH006G, UH007G	600	191R55-5
Shear blade 750 R set		750	191R56-3

Hedge trimmer single side blade



Name	Related models	Cutting width mm	Part No.
Shear blade 600E set	DUH604S, DUH754S, UH013G, UH014G	600	191Y03-6
Shear blade 750E set		750	191Y05-2

Pole hedge trimmer blade



Name	Related models	Cutting width mm	Part No.
Shear blade 460 assembly set	DUN461W, UN460WD	460	191P00-8
Shear blade 500 set	DUN500W, DUN501W	500	191C14-9
Shear blade 500S set			191E73-5
Shear blade 600 set	DUN600L	600	191C13-1
Shear blade 600R set	UN001G		1914E7-7
Shear blade 600S set	DUN600L		191F60-0

Hedge trimmer blade for attachment



Name	Related models	Cutting width mm	Part No.
Shear blade 250 set	EN422MP	250	1912G2-9
Shear blade 330 set	EN424MP, EN425MP	330	1912V6-6
Shear blade 500 set	EN402MP	500	1912G3-7
	EN425MP		1916X3-0
Shear blade assembly set MG	EN410MP	250	197763-8
	EN420MP		198195-2

Chip receiver assembly set

Still photo	Name	Related models	Blade size mm	Part No.
	Chip receiver set	DUM111, DUM604, UH201D, UM600D	-	198401-5
		UH200D		195278-9
		UH200D, UM164D		195279-7
	Chip receiver assembly 460 set	DUN461W, UN460WD	460	191T43-4
	Chip receiver assembly set	DUH483, UH4261, UH4861, UH5261	420-520	195050-9
		UH4570, UH5570, UH5580, UH6570, UH6580, UH7580	450-750	194681-1
	Chip receiver 500 set	DUH506, DUH507	500	1910T1-0
-	-	DUN500W, DUN501W		1910M5-3
	Chip receiver 500E set	DUH501, DUH502		191W56-3
	Chip receiver 600 set	DUH606, DUH607, UH021G, UN001G	600	1910T2-8
-		DUN600L		1910M6-1
	Chip receiver 600E set	DUH601, DUH602		191R51-3
	Chip receiver 600E set	UH013G	600	191D33-1
	Chip receiver 750 set	UH014G	750	191D34-9
	Chip receiver 750E set	DUH751, DUH752		191R52-1

Hook holder for extension cord

Still photo	Name	Related models	Part No.
	Arm band complete set	BO001CG, BO002CG, BO003CG, BO004CG, BO005CG, BO006CG, BO007CG, UH4261, UH4570, UH4861, UH5261, UH5570, UH5580, UH6570, UH6580, UH7580	194679-8
	Cord holder complete set	DUP361, DUP362, UH4261, UH4570, UH4861, UH5261, UH5570, UH5580, UH6570, UH6580, UH7580	194677-2

Machine grease

Name	Related models	Capacity g	Part No.
Grease vessel set	DUH501, DUH502, DUH506, DUH601, DUH602, DUH604S, DUH606, DUH751, DUH752, DUH754S, DUR369A, DUR369L, DUR369N, DUX60, UH004G, UH005G, UH006G, UH007G, UH008G, UH009G, UH013G, UH014G, UN001G, UR006G, UR007G, UR008G, UR016G, UR017G, UR101C, UR201C, UR202C	85	199450-5

Standard blade



Name	Related models	Cutting width mm	Part No.
Blade 330	DLM330	-	GB00000042
Blade 380 set	DLM382	380	191D41-2
	LM003G		196863-1 1913G8-3
Blade 430 set	DLM432	430	191D43-8
			196060-9
			196061-7
			197761-2
	LM004G		197762-0
Blade 460 set	DLM462, DLM465	460	1913H4-8
Blade 480 set	DLM480, DLM481, LM001G, LM001J, LM003J	480	191V97-3
Blade 530 set	DLM530, DLM532, DLM533, DLM534, DLM536, DLM537, LM001C, LM002G, LM004J	530	191D52-7
	DLM530, DLM532, DLM533, DLM538, DLM539, LM001C, LM002G, LM002J, LM004J		191V96-5

Collecting grass blade



Name	Related models	Cutting width mm	Part No.
Blade 460 set	DLM462, DLM465, DLM466	460	191W86-4
Blade 530 set	DLM530, DLM532, DLM533, DLM534, DLM536, DLM537, DLM538, DLM539, LM001C, LM002G, LM002J, LM004J	530	191W87-2

Mulching blade





Name	Related models	Cutting width mm	Part No.
Blade 460 set	DLM462, DLM465, DLM466	460	191Y63-8
Blade 480 set	DLM480, DLM481, LM001G, LM001J, LM003J	480	191Y64-6
Blade 530 set	DLM530, DLM532, DLM533, DLM534, DLM536, DLM537, DLM538, DLM539, LM001C, LM002G, LM002J, LM004J	530	191Y65-4
Mulching blade 380 set	LM003G	380	1913H0-6
Mulching blade 430 set	LM004G	430	1913H6-4

Swing back blade

Still photo	Name	Related models	Cutting width mm	Part No.
	Swing back blade 460 complete set	DLM462, DLM465	460	191D49-6
	Swing back blade 460 set		-	191D47-0
	Swing back blade 480 complete set	LM001G, LM003J	480	1911B0-2
	Swing back blade 480 set		-	1911P1-8
	Swing back blade 530 complete set	DLM530, DLM532, DLM533, DLM536, DLM537, LM001C, LM002G, LM004J	530	191D50-1
	Swing back blade 530 set		-	191D48-8

Outdoor Power Equipment





Mulching plug set for lawn mower

Still photo	Name	Related models	Part No.
-	MULCHING PLUG	DLM330	GB0000067
	Mulching plug 380 set	LM003G	1913H2-2
	Mulching plug 430 set	LM004G	1913H8-0
	Mulching plug set	DLM382, DLM432	191D46-2



Robotic mower blade

Still photo	Name	Related models	Part No.
	Blade set G	RM350D	1913M9-3



Accessory for robotic mower

Still photo	Name	Related models	Part No.
	Peg set G	RM350D	1913N6-6
	Terminal block set G		1913N8-2
	Wire 150M set G	RM350D	1913N2-4
	Wire repair set G		1913N4-0







Thatching blade

Still photo	Name	Related models	Part No.
	Dethatching blade	DUV320	YA00001317
	Thatching blade set	UV001G	1913J7-6

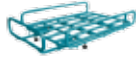



Vertical cutter

Still photo	Name	Related models	Part No.
	Scarifying blade	DUV320	YA00001316
	Vertical cutter set	UV001G	1913J5-0

Wheelbarrow attachment

Still photo	Name	Related models	Part No.
	Bucket set	DCU180	198494-2
			199008-0
	Pipe frame set		198491-8
	Carrier set		199009-8
			199116-7
	Dump bucket 200 set	DCU602, DCU603, DCU604, DCU605	191B67-2
	Dump unit set	DCU603, DCU604, DCU605	191B69-8
	Flat bucket set		1914G7-1
			191B63-0
			1911B3-6

Wheelbarrow wheel

Still photo	Name	Related models	Part No.
	Auxiliary wheel attachment set	DCU180	191A01-6
	Gray tire 210 (single) set	DCU601, DCU602, DCU603, DCU604, DCU605	1911K6-3
	Gray tire 330 (single) set		1911K5-5
	Tire 330 (single) set		1911K4-7

Accessory for grease gun









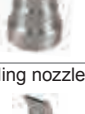

Still photo	Name	Related models	Length m	Capacity g	Max operating pressure mpa	Connection type	Part No.			
	Adapter set (1 pc)	DGP180, GP001G	-	-	-	-	1915L9-8			
	Adapter set (3 pcs)	DGP180			69	NPT1/8	191W60-2			
		GP001G			-	-	1915M0-3			
	Angle adapter set	DGP180, GP001G			69	-	1916U8-9			
	Barrel assembly A set	DGP180			400	-	1910X0-0			
	Barrel assembly B set				450	-	1910X1-8			
	Barrel assembly C set				500	-	1910T7-8 1910X3-4			
	Cartridge barrel A set				-	-	-	191F24-4		
	Cartridge barrel assembly A set							400	1910T3-6	
	Cartridge barrel assembly B set							450	1910T4-4	
	Cartridge barrel assembly C set							500	1910T5-2	
	Cartridge barrel assembly C set								1910T6-0	
	Cartridge barrel B set								450	1910X4-2
	Cartridge barrel C set		500	191F27-8						
	Extension pipe set		DGP180, GP001G	0.16				69	NPT1/8	1911M9-1
	Flexible hose 1200 set			1.2						1916S5-1
	Flexible hose 600 set			0.6						1916S7-7
	Joint set	GP001G	-	-	-	1915E6-5				
	Loader fitting set	DGP180, GP001G	-	-	-	1914G9-7				
	Lock on adapter set					1915N4-2				

Holder for caulking gun

Still photo	Name	Related models	Capacity ml	Type	Part No.
	Holder A set	CG100D, DCG180	300	A	196351-8
	Holder B set		600	B	1911T4-0
	Holder C set		800	C	197195-9
	Holder D set		400	D	1911T5-8



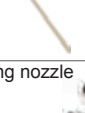













Heat gun accessories



For Model	Shape	Part No.	
DHG181, DHG180, HG6031V, HG6030, HG5030, HG6530V, HG6531C	Glass protection nozzle 	PR00000028	
	Wide-slot nozzle 	PR00000029	
	Reflector nozzle 	PR00000030	
	Reduction nozzle 20 	PR00000031	
	Overlap welding nozzle 	PR00000032	
	Solder sleeves reflector 	PR00000033	
	Welding nozzle 	PR00000034	
	Pressure roller 	PR00000035	
	Scraper 	PR00000040	
	Scraper set 	PR00000041	
	Scraper 	PR00000042	
	HG6031V, HG6030, HG5030, HG6530V, HG6531C	Welding rods 	ABS PR00000036 HDPE PR00000037 PP PR00000038
		Speed welding nozzle 	PR00000039

Rechargeable Green Multi Line Laser accessories



*Thread size: W5/8

Model No.	Shape	Part No.
SK312GD, SK209GD, SK700GD, SK700D, SK106D/GD, SK105D/GD	Mini tripod *Thread size: W5/8 Height adjustment range: 424-1,140mm 	TK0LM2000F
	Tripod 1800 *Thread size: W5/8 Height adjustment range: 670-1,800mm 	TK0LM4001F
	Tripod 2900 *Thread size: W5/8 Height adjustment range: 790-2,870mm 	TK0LM5030F
SK40GD, SK20GD, SK10GD	Mount 	TK00ET03F1
SK700DGD, SK106D/GD, SK105D/GD		LE00870137
SK312GD, SK209GD	Power supply cable USB Type A 	199006-4
SK106GD, SK105GD		199178-5
SK312GD, SK209GD SK106GD, SK105GD	Hand strap set 	199007-2
		Adapter for USB 
SK106D/GD, SK105D/GD SK700D/GD	Laser Receiver LDX1 	LE00855702
SK312GD, SK209GD	Laser Receiver LDG-3 	TK0LDG301F
SK40GD, SK20GD, SK10GD, SK312GD, SK209GD	Laser Receiver LDG-5 	TK0LDG501F
SKR001	Remote RC1 	LE00981929
	LDx2 digital rotary laser receiver set 	LE00981928
	Wall mount for rotary laser, metal 	LE00981930
	CXT battery tray 	LE00981911
	LXT battery tray 	LE00981912
	XGT battery tray 	LE00981913







Lamp shade

Still photo	Name	Related models	Part No.
	Lamp shade	DML809	GM00002286
		DML811	GM00002287
		DML816, ML006G	GM00001326
		DML817, ML011G	GM00002457
		ML005G	GM00002358
		ML009G	GM00002377
		ML107	GM00002476

Anti-glare film

Still photo	Name	Related models	Part No.
	Anti-glare film	ML003G	GM00002312
		ML005G	GM00002359
		ML009G	GM00002376



Strap

Still photo	Name	Related models	Part No.
	Strap	DML812	GM00002239
		ML104	GM00001028
		DML817, ML011G, ML107	SE00001178
		ML012G, DML818	GM00002544
	Hand strap with metal strap ho	ML007G	GM00002373
	Hook band set	ML001G	GM00002280
	Shoulder hook set	ML006G, DML816	GM00001288

Telescopic hook for flashlight

Still photo	Name	Related models	Part No.
	Telescopic hook	ML012G, DML818	GM00002545

Tripod, stand

Still photo	Name	Related models	Part No.
	Flat bar	DML809, DML811, ML003G	GM00002379
	Tripod	DML809, DML811, ML003G, ML005G, ML009G	GM00002378



Vise

Still photo	Name	Related models	Part No.
	VISE	DML805, ML003G, ML005G, ML009G	GM00001396

Magnet

Still photo	Name	Related models	Part No.
	Magnet attachment	ML105, ML104	GM00001714

Fan unit cable



Still photo	Name	Related models	Type	Part No.
	Cable unit set	DFV214A, DFV215A	C	191T97-1
			A	191U58-7

Filter set





Still photo	Name	Related models	Type	Part No.
	Filter (20 pcs)	DFV214A, DFV215A	Non-woven	198643-1
	Filter set			198641-5
				198642-3

Others



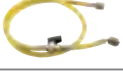

Pump adapter

Still photo	Name	Related models	Part No.
	Ball adapter	DMP180, DMP181, MP001G, MP100D	TE00000592
	French adapter		TE00000594
	Swim ring adapter		TE00000333



Accessory for vacuum pump

Still photo	Name	Related models	Part No.
	Adapter	DVP180, DVP181	AS0Y06110K
	Hose packing (6 pcs)	DVP180	AS000A158
	Intake shut-off valve with		AS0VP051MK
	Vacuum gauge		AS00XP808M
	Vacuum hose		AS0AI154MK
-	Vacuum pump oil		DVP181



Flexible shaft

Still photo	Name	Related models	Shaft diameter mm	Shaft length m	Part No.
	Flexible shaft 32-1.2 set	VR001G, VR003G, VR004G	32	1.2	1910E1-5
	Flexible shaft 32-1.7 set			1.7	1910E2-3
	Flexible shaft 32-2.4 set			2.4	1910C2-9
	Flexible shaft 38-1.2 set		38	1.2	1910E3-1
	Flexible shaft 38-2.4 set			2.4	1910C4-5

Battery case

Still photo	Name	Related models	Compatible battery	Part No.
	Battery case H set	VR001G, VR003G, VR004G	XGT 4AH<=, portable power pack	1910J4-4
		VR003G, VR004G		1910J5-2
	Battery case L set	VR001G, VR003G, VR004G	XGT 5AH>=	1910J1-0
		VR003G		1910J2-8

Battery protector



Still photo	Name	Related models	Part No.
	Battery protector set	DDA350, DDA351, DDF451, DDF453, DHP451, DHP453, DHR202, DTD152, DTD153, DTD173, DTD201, DTL061, DTL063, DTS141, DTW251, DTW253, DTW450	194649-7
		DDF458, DHP458	195798-3
	Cover L set	UT001G, UT002G	1911R6-2

Accessory for cooler and warmer box



Name	Related models	Part No.
Cove	CW001G	CE00000001
	CW002G	CE00000002
	CW003G	CE00000003
	CW004G	CE00000004

Cigar socket cable

Still photo	Name	Related models	Part No.
	Cigar lighter DC 12-24V	CW001G, CW003G, DCW180	WL00000002
		DCW180	WL00000139
	Cigar lighter	CW002G	WL00000225
-	Cigar socket	CW004G	CE00000007

Harness for battery adapter

Still photo	Name	Related models	Part No.
	Harness set	BO001CG, BO002CG, BO003CG, BO004CG, BO005CG, BO006CG	1914H8-6

Shoulder strap

Still photo	Name	Related models	Type	Part No.
	Belt	DVP180	-	AS000VP042
	Harness cover set	DVC261, DVC265, VC008G, VC009G		191Y14-1
	Ring set	DTW1004	Ring set	1913P0-2
		TW001G		191M83-0
	Shoulder belt	CW004G	-	A-76956
		DML813, DML814		TD00000002
	Shoulder belt set	DVC750L, VC013GL, VC014GL	-	199486-4
	Shoulder strap	DUS054, US053D	-	PR00000128
	Shoulder strap set	DSC102, SC103D	-	199069-0
	Tool catcher set (with strap)	DTD152, DTS141, DTW190, DTW251, DTW253, DTW300, DTW301, DTW302, TW202D	With strap	197941-0

Tool catcher

Still photo	Name	Related models	Part No.
	Tool catcher set	DTD153, DTD157, DTD173	197043-2
		DTW190, TW202D	197940-2
	Tool hanger set	DHR182	199593-3
		DHR183, HR010G	1911K0-5
		DTD201, DTW300, DTW301, DTW302, TW004G, TW005G	191K57-9
		HR3001C, HR3011FC, HR3012FC	191F45-6
		TD001G	191F58-7

Hook set

Still photo	Name	Related models	Type	Part No.	
	Hook complete set	UC029G	-	1914Y8-5	
		DCS553		199296-9	
	Hook set	DHS660, DHS661	-	199231-7	
		DHS780, DHS781, DHS782, DHS783, HS003G, HS004G		199386-8	
		HR007G, HR008G, HR009G, HR011G, HR012G		191W90-3	
		JR3051T		191C05-0	
		AS001G, DAS180, DCO181, DTD173, DTS141, DTW190, TD127D, TW202D		195779-7	
		SD100D		Wide	197224-8
		Wide hook set		DDA350, DDA351, DDF451, DDF453, DHP451, DHP453, DTD152, DTD153, DTD157, DTD201, DTL061, DTL063, DTP141, DTW251	-

Battery adapter & battery converter

Still photo	Name	Related models	Cable length m	Part No.
	Adapter set	DHR263, DHR264, DHS710, DJR360, DLS714, DUB361, DUB362	-	197718-3
	Battery adapter set	BO001CG, BO002CG, BO003CG, BO004CG, BO005CG, BO006CG	5	1914H5-2
		BO001CG, BO002CG, BO003CG, BO004CG, BO005CG, BO006CG, BO007CG	1.6	1914H3-6
		BO002CG, BO003CG	5	1914N5-4
		BO002CG, BO003CG, BO007CG	1.6	1914N4-6
	Interchangeable adapter set ADP10	Model ADP10 is an interchangeable adapter developed for use with XGT charger to charge LXT Li-Ion batteries.	-	191C10-7 191C11-5 191P33-3

Battery communication connector

Still photo	Name	Related models
	Communication connector set	ADP12
		ADP13

Others

Battery adapter & Battery converter

BAP182



BCV01



BCV03



Type	Battery type	For Model
BAP182	LXT 18V Battery x2	LXT 18Vx2 Model
BCV01		Old 36V Models
BCV03		
BAP18 BAP18C	LXT 18V Battery	LXT 18V

String trimmer harness for PDC1200 / PDC1500



Item	Part No.
A	191E43-4
B	197243-4

Blower harness for PDC1200/ PDC1500



Part No.
191J48-4

Battery adapter for LXT 18V Battery models



Part No.
191A53-7

Battery adapter for PDC1200, PDC1500 & XGT 40V Battery models



Part No.
191N62-4

Battery adapter for PDC1200, PDC1500 & LXT 18Vx2 Battery models



Part No.
191J51-5
191A52-9

Portable Battery Checker

*BTC04 is also necessary
*With SD card for BTC04 software update.

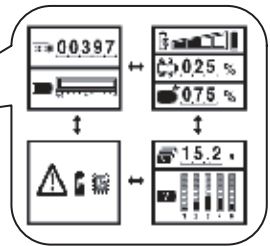

Your PC and your USB cable



Checking time: 3-5sec.

Battery type	Battery Checker	market	Parts No.
Except XGT, CXT, G battery, BL6440, BL64100, BL3622A, BL36120A, PDC1200, PDC1500	BTC04	-	198038-8
		-	198200-5
		CANADA U.S.A.	198199-4
XGT battery	*BTC05	-	191K30-9
CXT battery	BTC06	-	-
PDC1200, PDC1500 BL6440, DL64100	*BTC07	-	191Y78-5

Battery Timer Setting Adapter

The Battery Timer Setting Adapter provides an anti-theft solution for Makita-brand battery cartridges by utilizing the mobile devices or PCs (with the dedicated app installed) required for timer setup. Applicable lithium-ion battery

- BL1430B BL1460B
- BL1820B BL1830B BL1840B BL1850B BL1860B

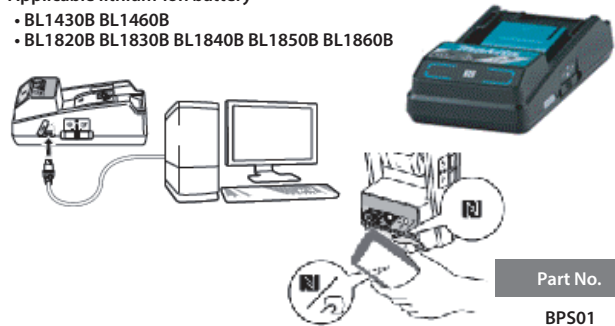

Part No.
BPS01



Makita - A Global Brand

Makita have established directly operated business bases in about 50 countries around the world, and have upgraded our sales network in over 170 countries and after-sales service capabilities to become one of the leading companies in our industry. In addition, Makita is producing power tools and OPE in China, Romania, Thailand, U.K., Brazil, U.S. and Germany. Currently, about 90% of our group's manufacturing work in terms of production volume is carried out overseas.

Makita's worldwide sales and service network, as well as the stable, high production quality ensured at its plants worldwide, are the embodiment of the Makita brand.

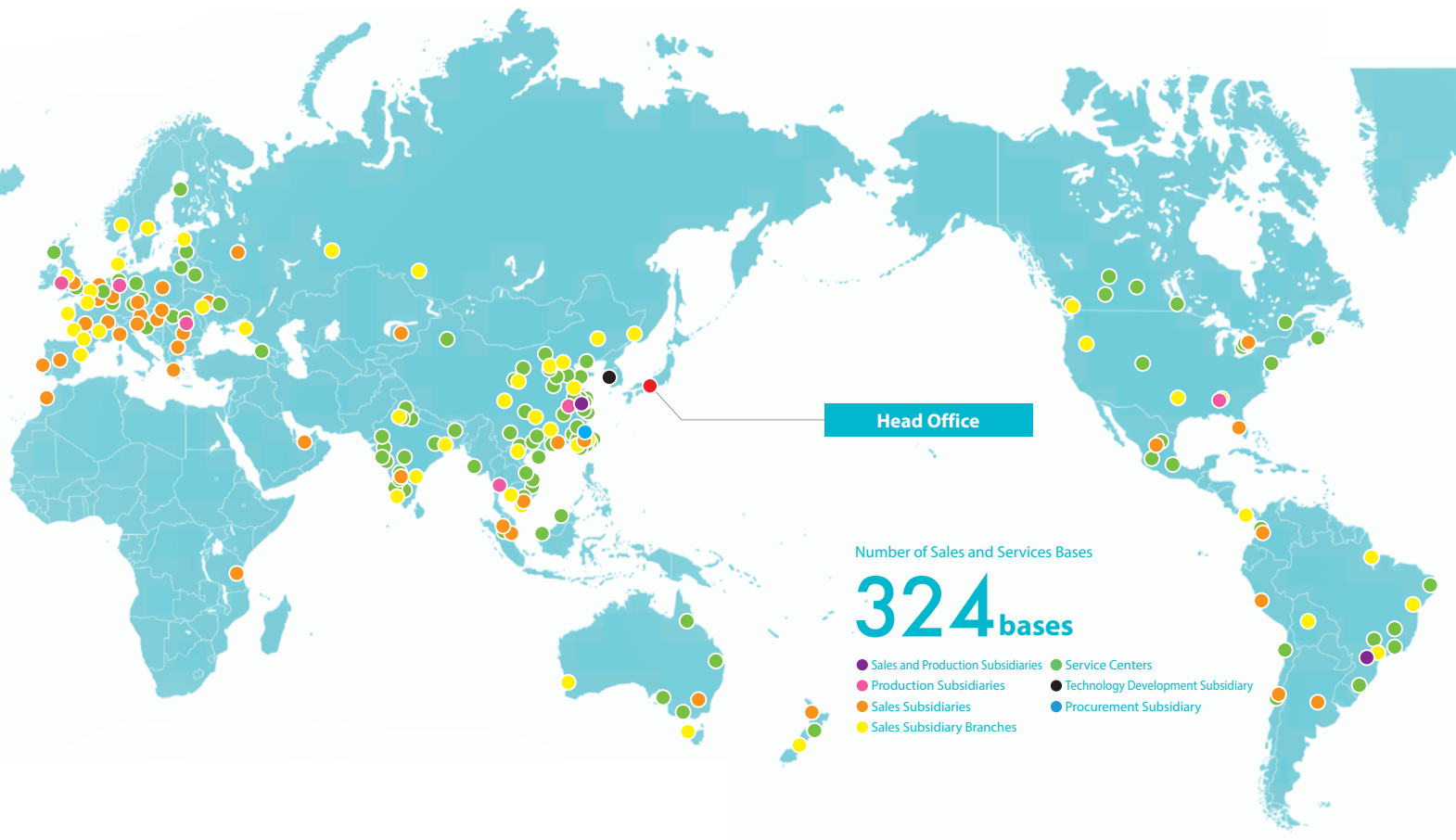

JAPAN

Makita Corporation Headquarters



JAPAN

Okazaki Plant



U.S.A.

U.S. Plant



UNITED KINGDOM

U.K. Plant



ROMANIA

Romania Plant



GERMANY

Germany Plant



BRAZIL

Brazil Plant



CHINA

China Plant (MCC)



CHINA

China Plant (MKC)



THAILAND

Thailand Plant



JAPAN**Makita Corporation****Head office**

3-11-8, Sumiyoshi-cho, Anjo, Aichi
446-8502

Okazaki plant

22-1, Watarijima, Nemunoki-cho,
Okazaki, Aichi 444-0232

Nisshin Office

349 Minamiyama,
Komenoki-cho, Nisshin,
Aichi 470-0111

Tokyo branch office

3-5-3, Hongo, Bunkyo-ku,
Tokyo 113-0033

Nagoya branch office

2-33, Namiki, Nakamura-ku,
Nagoya 453-0856

Osaka branch office

1-26-8, Tenma, Kita-ku,
Osaka 530-0043

Domestic sales offices

Sapporo, Sendai, Niigata, Utsunomiya,
Saitama, Chiba, Yokohama, Shizuoka,
Gifu, Kanazawa, Kyoto, Hyogo, Okayama,
Hiroshima, Takamatsu, Fukuoka,
Kumamoto, Okinawa and other major cities

CHINA**Makita (China) Co., Ltd.****Head office & plant (MCC)**

No.1388 Middle Huangpujiang Road,
Kunshan Economic & Technical
Development Zone, Jiangsu, China
Postcode: 215335

Domestic sales department (MCS/MCCF)

No.318, South Wusongjiang Road,
Kunshan City, Jiangsu, China
Postcode : 215300

Domestic sales department (MCCS)

No.80 Meigui Road, Kunshan Economic
& Technical Development Zone, Jiangsu,
China
Postcode : 215300

Guangzhou sales branch (CGZ)

Rome 1001 1002, The First Floor, Jinhao
Building, No.38, Middle Of Huadi
Avenue, Li Wan
District, Guangzhou, Guangdong, China
Postcode : 510380

Shanghai sales branch (CSH)

Room.102&103, 1F, No.128, East Luoxiu
Road, Xuhui District, Shanghai, China
Postcode : 200231

Tianjin sales branch (CTJ)

No.3 Office Building, No.23, Quanwang
Road, Wuqing Development
Area, Tianjin, China
Postcode : 301700

Chengdu sales branch (CCD)

3F, Building No.1, No.39 Xiedu South 3
Rd, Wuhou District, Chengdu, Sichuan,
China
Postcode : 610045

Shenyang sales branch (CSY)

No.27, Shenxin East Road, TieXi District,
Shenyang, Liaoning, China
Postcode : 110000

Xian sales branch (CXA)

1 & 2F, Xian Youzhi Science and
Technology Industrial Park NO.75
Mingguang Road, Economic And
Technological Development Zone, Xian,
Shanxi, China
Postcode : 710018

Changsha sales branch (CCS)

(Near Gaosheng Road) No.3, Building
5, Youxin Mechanical And Electrical
Market, Yuhua District, Changsha, Hunan,
China
Postcode : 410114

Shijiazhuang sales branch (CSJ)

No.102, 1F, 2nd Plant, No.403, Yuhua
East Road, Yuhua District,
Shijiazhuang, Hebei, China
Postcode: 050000

Makita (Kunshan) Co. Ltd.

No.1, Nanzi Road, Kunshan Economic &
Technical Development Zone,
Jiangsu, China
Postcode: 215301

Makita Power Tools (HK) Limited**Head office**

Unit 01, 17/F & 3/F., Grandtech Centre, 8
On Ping Street, Shatin, N.T., Hong Kong

Macau Service Centre

Em Macau, Rua Do Volong N°11,
Rês-Do-Chão A

Makita (Taiwan) Ltd.**Head office**

No.798, Sec. 2, Wenhua 3rd Rd.,
Linkou Dist., New Taipei City 24459,
Taiwan

Taichung sales branch

No. 839, Section 3, Zhongqing Rd, Daya
Dist, Taichung City, 428, Taiwan

Kaohsiung sales branch

No.105, Yucheng Rd., Sanmin Dist.,
Kaohsiung City 807, Taiwan

Yilan factory service center

No. 237, Section 3, Chuanyi Rd, Luodong
Township, Yilan County, 265, Taiwan

Hualien factory service center

No.247, Sec.2, Zhongyang Rd.,
Ji'an Township, Hualien County 973,
Taiwan

Yunlin factory service center

No.197, Guangfu Rd., Huwei Township,
Yunlin County 632, Taiwan

Tainan factory service center

No. 182, Minzhi Rd, Xinying District,
Tainan City 730, Taiwan

Pingtung factory service center

No.12&16, Ruimin Rd.,
Pingtung City 900, Taiwan

Taitung factory service center

No. 51, Section 2, Zhongxing Rd, Taitung
City, Taitung County 950, Taiwan

SINGAPORE**Makita Singapore Pte. Ltd.****Head Office**

7, Changi South Street 3, Singapore 486348

Myanmar Service Center

No.D36/2, Lan Thit Road, Insein Township,
Yangon.

Cambodia Service Center

No. 432, Street 271, Phum Chamroen
Phal 4, Sangkat Boeung Tumpun 1, Khan
Meanchey, Phnom Penh, CAMBODIA.

INDIA**Makita Power Tools India Pvt. Ltd.****Head Office**

Unit 2, Sy. No. 93/3 & 93/4,
Koralur Village, Kasaba Hobli,
Hoskote Taluk, Bangalore – 560067. India.

Delhi Branch

Khasra No: 90/1, Main Phirni Road,
Extended Lal Dora, Village Bamnoli, New
Delhi – 110 077

Chennai Service Centre

No.30, Jawaharlal Nehru Salai,
Koyambedu, Chennai – 600107. India.

Kolkata Branch

P-46, Hide Road Extension,
Kolkata – 700088.
West Bengal. India.

Cochin Service Centre

Door No. XVI/443A, Jubilee Road, Kerala
– 682040. India

Bhiwandi Branch

Block 11, Building No. F-1, Situated at
Antariksh Logipark, Dohole Village,
Tal-Bhiwandi – 421 302

Ahmedabad Service Centre

Aniket Estate, Near Sawan Hotel, Near
Sarkhej – Sanand Chokdi, S. G. Highway,
Ahmedabad – 382210. India.

Peenya Service Center

No. 36/B, F1, 2nd Phase, 1st Main Road,
KIADB, NTF Circle, Peenya Industrial
Area, Bangalore - 560058

Pune Service Centre

Shop No. 104, First Floor, Plot No.
PAP/J/121/122. J Block, MIDC Bhoasari,
Pimpri Chinch Wad, Pune - 411026

Rudrapur Service Centre

MIG-48, Ground Floor, Ward No. 19, New
Ward no. 38, Near Siddhu Palace, Awas
Vikas, Rudrapur, Uttarakhand - 263153

Jamshedpur Service Centre

Shop no. 24, Shivanjani Complex, Plot
no. ST-8, Mouzadindli, Adityapur,
P.S.Adityapur Ward no. 5, Saraikel (D),
Kharswan, Jharkhand state, 831013

Indore Service Centre

Unit No. B-34, Block No. B-18, Access B,
New Siyaganj, Poddar Plaza, HTL, Unit 2,
VIP Route No.1, Kachhi Mohalla, Indore
,452007

Vadodara Service Centre

Shop No. 3, Lakod Complex, GIDC,
Makarpara, Vadodara, 390010, Gujarat

Guwahati Service Centre

Sahani Mansion, Chatribari Road,
Guwahati, Kamrup Metropolitan,
Assam - 781001, India.

Coimbatore Service Centre

D.No.138/6, Ground Floor, Rangakonar
Street, Katour, Coimbatore - 641009,
Tamilnadu.

VIETNAM**Makita Vietnam Co. Ltd.****Head office**

Unit 4-5-6, Block 16, 18L1-2, Street No. 3,
VSIP II Industrial Park, Binh Duong Ward,
Ho Chi Minh City, Vietnam

North Branch

Unit 05, No.01, Street 6, VSIP Bac Ninh
Intergrated Township and Industrial
Park, Tu Son Ward, Bac Ninh Province,
Vietnam

Da Nang Service Center

40 Chi Lang Street, Hai Chau Ward, Da
Nang City, Vietnam

Can Tho Service Center

366 Vo Van Kiet Street, 5 Zone, Binh
Thuy Ward, Can Tho City, Vietnam.

Buon Ma Thuot Service Center

68 Le Duc Tho, Buon Ma Thuot Ward,
Dak Lak Province, Vietnam

Hai Phong Service Center

No. 01 Lot OH-01, Hoang Huy Riverside
Project, Hong Bang Ward, Hai Phong
City, Vietnam

Nha Trang Service Center

Lot 36-38, B6 Street, Vinh Diem Trung
Urban Area, Tay Nha Trang Ward, Khanh
Hoa Province, Viet Nam

Ho Chi Minh Service Center

12 Trinh Van Can, Ben Thanh Ward, Ho
Chi Minh City, Viet Nam

Ha Noi Service Center

Group 15 and No. 4, Alley 63, Truong
Chinh Street, Phuong Liet Ward, Hanoi
City, Viet Nam

THAILAND**Makita Manufacturing (Thailand) Co., Ltd.**

219/1 Moo 6, Tambol Bowin,
Amphur Sriracha, Chonburi, 20230

MALAYSIA**Makita Power Tools (Malaysia) Sdn. Bhd.****Head Office**

Lot 824, Jalan Subang 5, Subang
Industrial Area,
47500 Subang Jaya, Selangor, Malaysia

Johor(Johor Bahru) Service Center

No. 12 & 14, Jalan Rosmerah 2/9,
Taman Johor Jaya, 81100 Johor Bahru,
Johor

Sarawak(Kuching) Service Center

Lot 1227, Lorong Demak Indah 2A,
Demak Laut Industrial Area, Phase 2A,
93050 Kuching Sarawak, Malaysia.

Sabah(Kota Kinabalu) Service Center

Lot 19, Jalan Buah Duku,
Kolombong Light Industrial Estate,
Off Kolombong, Kolombong Zone 1,
88450 Inanam, Kota Kinabalu, Sabah

AMERICAS

UNITED STATES

Makita U.S.A. Inc.

Corporate office

14930 Northam Street, La Mirada,
CA 90638-5753, USA

Western regional (Los Angeles) office

14930 Northam Street, La Mirada,
CA 90638-5753

Western regional (Reno) office

10200 Military Rd, Reno, NV, 89506

Eastern regional (Atlanta) office

4200 Falcon Parkway Flowery Branch,
GA 30542

Southern regional (Dallas) office

910 E. Pleasant Run Road, Wilmer, TX
75172

Factory service centers

Atlanta, Chicago, Dallas, Denver,
Los Angeles, New Jersey, Reno

Makita Corporation of America

2650 Buford Highway, Buford,
GA 30518-6045

Makita Latin America Inc.

Head office

9221 West 44th Ave. Suite 900, Hialeah,
FL 33018

Panama Branch

Local Comercial No.4, Albrook Office
Center, calle Diego Dominguez, Albrook,
Panama City, Panama

CANADA

Makita Canada Inc.

Head office

1950 Forbes Street, Whitby, ON L1N 7B7

Western regional office

11771 Hammersmith Way, Richmond,
BC V7A 5H6

Factory service centers

Edmonton, Les Saules (Quebec City),
Richmond (Vancouver), Saskatoon,
St. Leonard (Montreal), Whitby

MEXICO

Makita México, S.A. de C.V.

Head office

Camino Viejo A San Lorenzo Tepaltitlan
(Jose Marti) No.229 Lote1
Col. Tlacopa, Toluca, Estado De Mexico,
C.P. 50010

Mexico City sales branch

Avenida de los Cien Metros, número
1112, Colonia Nueva Industrial Vallejo,
Alcaldía Gustavo A. Madero, en la Ciudad
de México, C.P. 07700

BRAZIL

Makita do Brasil Ferramentas Elétricas Ltda.

Head office & plant (MBRP)

Rodovia BR 376, Km 506,1 - (pista norte)
Bairro Colônia Dona Luíza,
CEP 84043-450 - Ponta Grossa, PR

São Paulo sales office (MBR)

Rua Makita Brasil, 200 -Bairro
Cooperativa - São Bernardo do Campo -
SP CEP 09852-080

Bahia sales branch

Rua Itagi, 491- Bairro
Pitangueiras - Lauro de Freitas,
BA CEP: 42701-370

Rio de Janeiro service center

Av. Das Américas, 2250 - Loja J/K - Barra
da Tijuca -
Rio de Janeiro, RJ CEP:22640-101

Recife service center

Av. Marechal Mascarenhas de Moraes,
630, Bairro Imbiribeira,
Recife, PE CEP 51170-000

Belo Horizonte service center

Rua Juiz de Fora, 95 - Bairro Barro Preto,
Belo Horizonte, MG CEP 30180-060

Pará Sales Branch

Rodovia BR 316, Km 04 Loja 04-Bairro
Águas Lindas, Ananindeua / PA CEP
67020-000

Porto Alegre service center

Av. Sertorio, 5539 - JD. Lindoia - Porto
Alegre - RS CEP: 91050-371

Guauxupé service center

Av. Paulo Ribeiro do Valé, 1539 - Japy,
Guauxupe - MG, CEP 37800-000

Manaus sales branch

Av. Torquato Tapajós, 1762, Flores,
Manaus-AM, CEP 69058-830

ARGENTINA

Makita Herramientas Eléctricas de Argentina S.A.

LISANDRO DE LA TORRE 1246,
PARQUE INDUSTRIAL PILARICA,
FATIMA, PILAR PROVINCIA DE BUENOS
AIRES, CP1633

CHILE

Makita Chile Comercial Limitada

Head Office

AV.EL PARQUE 1307, PARQUE 5, MODULO
12, SECTOR ENEA PONIENTE PUDAHUEL,
SANTIAGO, CHILE CP9031244

Temuco factory service center

Avenida Pedro de Valdivia N°0524,
locales 13 y 14, Comuna y Ciudad de
Temuco

Antofagasta factory service center

Pedro Aguirre Cerda N°6259, locales 3 y
4, Comuna y Ciudad de Antofagasta

Copiapó factory service center

Panamericana Norte N°185, Bodega 10
Edificio 3, Comuna y Ciudad de Copiapó

PERU

Makita Peru S.A.

Panamericana Sur - Km. 29, Distrito de
Lurin, Provincia de Lima Centro de
Operaciones "MEGACENTRO LURIN"
Locales B1, B2, B24

Bolivia Branch

Av. Japón Nro. 3340 (3er. Anillo externo)
entre Av. Alemana y Mutualista

COLOMBIA

MAKITA COLOMBIA S.A.S

Head Office

Bodega 3 Lote 123, Centro Empresarial
Celta Trade Park, Kilometro 7 Autopista
Bogotá-Medellín Funza, Cundinamarca,
Colombia

Paloquemao factory service center

Carrera 22#18-63, Bogota,
Cundinamarca, Colombia

EUROPE

UNITED KINGDOM

Makita (U.K.) Ltd.

Head office

Michigan Drive, Tongwell, Milton
Keynes, Bucks MK15 8JD

Wigan Warehouse

Challenge Way, Martland Park, Wigan,
WN5 0LD

Scotland factory service center

Unit 4A, Albion Trading Estate,
750 South Street, Glasgow, G14 0SY

London factory service center

Unit 5 Vector Park, Forest Road, Felthm,
Middlesex, TW13 7EJ

Makita Manufacturing Europe Ltd.

Hortonwood 7, Telford, Shropshire TF1
7YX

FRANCE

Makita France SAS

Head office

37, avenue Graham Bell, ZAC Léonard de
Vinci, Bussy Saint-Georges, 77607
Marne-la-Vallée Cedex 3

Nantes office

Le Pan Loup, 44220 Couéron

Bordeaux office

137, Rue de la Croix-de-Monjou, 33170
Gradignan

Nord office

Village d'Entreprises, 51, Rue Trémière,
59650 Villeneuve d'Ascq

Toulouse office

15, Rue de Boudeville, Z.I. de Thibaud,
31104 Toulouse

SPAIN

Makita, S.A.

Head office

Calle Cerceda, nº 28 28052 Vicálvaro
(Madrid)

Barcelona Office

Bio Edificio Gonsi Sócrates Calle Antonio
Machado nº 65 08840 Viladecans
(Barcelona)

PORTUGAL

Makita - Ferramentas Eléctricas, Sociedade Unipessoal, Lda.

portugal sales division

Centro empresarial de Alverca, Vale das
Ervas, Armazém C2 2615-187 Alverca do
Ribatejo

ITALY

Makita S.p.A.

Via Don Luigi Sturzo 56/58, Arluno,
20004, Milano, Italy

GREECE

Makita Hellas S.A.

Tatoiou 34, Acharnes, ATTIKI PC13677

FINLAND

Makita Oy

Tuotantitie 21, 04300 Tuusula, Finland

FSC

Krouvintie 5 90400 Oulu, Finland

ESTONIA

Makita Oy Estonian Branch

Head office

Kaupmehe tn 5, Laagri alevik, 76401
Saue vald, Estonia

LATVIA

Makita OY Latvian Branch

Latvian factory service center

Vienibas gatve 153/1, Mārupe, Mārupes
nov., LV-2167, LATVIA

LITHUANIA

Makita OY Lithuanian Branch

Lithuanian factory service center

L. Zamenhofo Str. 3, Vilnius, LT-06332,
LITHUANIA

SWEDEN

Makita Sweden

Bergkällavägen 36A 192 79
SOLLENTUNA
SWEDEN

NORWAY

Makita Norway

Løxaveien 15 1351 Rud Norway

THE NETHERLANDS

Makita Nederland B.V.

Head office

Park Forum 1101 5657HK Eindhoven

Utrecht Service Center

Straat van Gibraltar 6, 3446CM Woerden

BELGIUM

S.A. Makita N.V.

Jan-Baptist Vinkstraat 2 3070 Kortenberg

Boom warehouse

Industrieweg 1C
2850 Boom

GERMANY

Makita Werkzeug GmbH

Head office

Makita Platz 1, 40885 Ratingen

Makita Service Center Hamburg

Jenfelder Strasse 51, 22045 Hamburg

Makita Service Center Berlin

Gartenfelder Strasse 29 – 37
Gebäude 44, 13599 Berlin

Makita Service Center Lehrte

Everner Strasse 30, 31275 Lehrte

Makita Service-Center Groß-Gerau

Hans-Böckler-Str. 22
64521 Groß-Gerau

Makita Service Center München

Martin-Kollar-Straße 4, 81829 München
EG VE 04

Makita Engineering Germany GmbH

Jenfelder Strasse 38, 22045 Hamburg

DENMARK

Makita Elværktøj Danmark

Denmark office

Vegavej 17, 8700 Horsens, Kingdom of
Denmark

SWITZERLAND

Makita SA

Chemin du Vuasset 7 CH-1028
Preverenges

AUSTRIA

Makita Werkzeug Gesellschaft m.b.H.

Airportstraße 4 A-2401 Fischamend

SLOVENIA

MAKITA.d.o.o.

Brncičeva 17, SI-1231 Ljubljana-Črnuča,
Slovenia

CROATIA

Croatia factory service center

Kreše Golika 3A, HR- 10000 Zagreb

EUROPE

UKRAINE

Makita Ukraine LLC

61 Oleha Onikiyenka Str., Brovary, Kyiv region 07400, Ukraine

Dnipro FSC

5 Kursanta Ckorobogatka Str., Dnipro, Dnipropetrovsk region 49124, Ukraine

POLAND

Makita Sp. z o.o.

Head office

ul. Bestwińska 103
43-346 Bielsko - Biała

Warsaw branch

Moszna-Parcela 29
05-840 Brwinów

CZECH REPUBLIC

Makita, spol. s r.o.

Tovární 941/1a Brno – Chrlce, 643 00
Czech Republic (CZ)

Prague Service Center

K Bílému Vrchu 3040/16, 193 00
Prague 9

SLOVAKIA

Makita s.r.o.

Priemysel'ná 26
974 01 Banská Bystrica

HUNGARY

Makita Elektromos Kiszgépértékesítő Kft.

8000 Székesfehérvár, Kukorica u. 7.

ROMANIA

Makita Romania S.R.L.

Strada Garii Nr.6, Loc.Branesti, jud.Ifov, Romania

Cluj-Napoca Factory Service Center

Str. Bld. Muncii, Nr. 68, 400641
Cluj, Romania

Iasi Factory Service Center

Boulevard Poitiers No. 2, 700671
Iasi, Romania

SC Makita EU SRL

Str.I.C. Bratianu, nr.164, Comuna Branesti, jud. ILFOV, ROMANIA 077030

BULGARIA

Makita Bulgaria EOOD

Okolovrasten Pat (circle road), No.373,
Sofia 1186, Bulgaria

GEORGIA

LTD «Makita Georgia»

64, D. Guramishvili avenue, 0141, Tbilisi,
Georgia

KAZAKHSTAN

Makita Kazakhstan LLP

Zakarpatskaya str., 45, 050039, Almaty,
Kazakhstan

MIDDLE EAST/ AFRICA

UNITED ARAB EMIRATES

Makita Gulf FZE

P.O. Box 17133,
Jebel Ali Free Zone, Dubai, UAE

TANZANIA

MAKITA AFRICA LIMITED

P.O. Box 20998,
2nd Floor, Staywell Office Building, Haile
Selassie Road, Msasani Peninsula, Dar es
Salaam, Tanzania

MOROCCO

MAKITA MOROCCO SARL

Rte Zenata Lot Marhaba Show Room N5
Espace Commercial Asteria Amal 5 A S,
20250 Casablanca, Morocco

OCEANIA

AUSTRALIA

Makita (Australia) Pty. Ltd.

Head office

2 Litton Close Pemulwuy. NSW. 2145

Hobart office

32a Chapel Street Glenorchy, TAS 7010

Perth office

374A Kenwick Rd Maddington WA 6109

Factory Service Center

Sydney, Melbourne, Brisbane, Perth,
Hobart, Townsville, Adelaide

NEW ZEALAND

Makita (New Zealand) Limited

Head office

46 Westpoint Drive, Hobsonville,
Auckland 0618

Christchurch Office

27 Hannover Place, Rolleston,
Christchurch 7614

Factory Service Center

Auckland North, Auckland South,
Christchurch, Wellington

Product Catalogue



Makita Corporation
3-11-8 Sumiyoshi-cho, Anjo, Aichi 446-8502 Japan
www.makita.com



**official YouTube
channel**



www.makita.com